

FIT	BETWEEN PARTS
H8/f7	4 AND 5
H7/p6	3 AND 5
H8/f7	2 AND 4

PARTS LIST			
ITEM	QTY	PART NUMBER	MATERIAL
1	1	TOP PLATE	MALLEABLE IRON
2	1	WHEEL	MALLEABLE IRON
3	2	AXLE SUPPORT	MALLEABLE IRON
4	1	AXLE	SAE 1020
5	2	BUSHING	BRONZE

METRIC

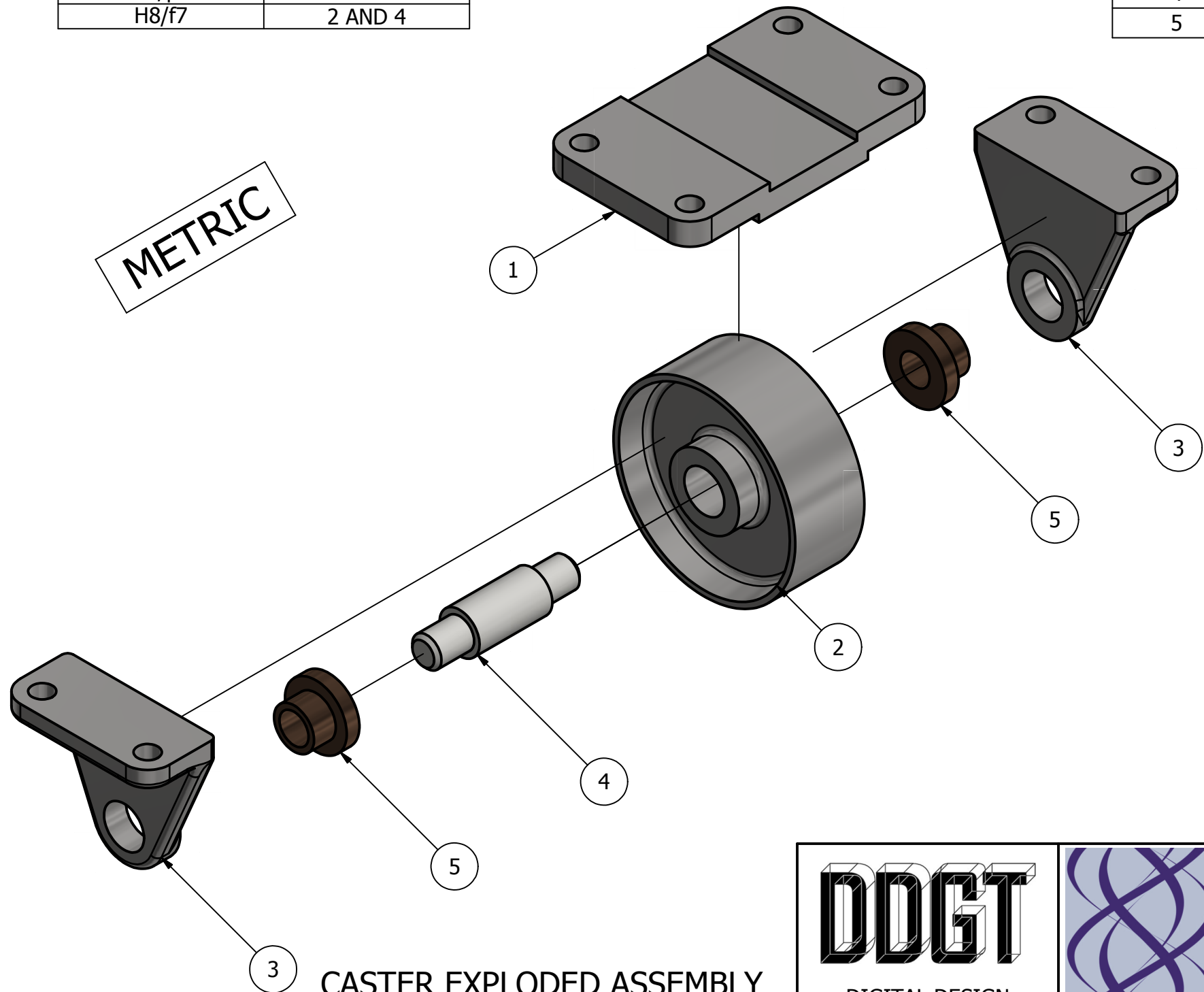

CASTER EXPLODED ASSEMBLY  
SCALE 1 / 2

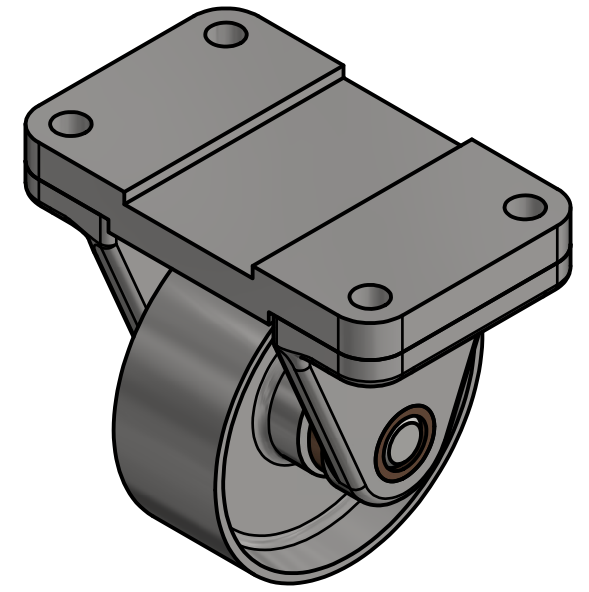

CASTER ASSEMBLY  
SCALE 1 / 2

**LEGEND:**

- ∅ DIAMETER
- R RADIUS
- ° DEGREE

**DDGT**  
DIGITAL DESIGN  
GRAPHICS  
TECHNOLOGY  
WWW.DDGT.NET

Alexzander Kuykendall  
Draftsman and Graphic Designer  
(707) 980-5920  
alexjkuykendall@gmail.com  
[www.ddgt.net/StudentPages/akuykendall](http://www.ddgt.net/StudentPages/akuykendall)

TOLERANCES UNLESS SPECIFIED  
MILIMETERS:  
WHOLE NUMBERS = ±.5  
X = ±.25  
XX = ±.12  
ANGLES ± 1 DEGREE  
SURFACES  $\sqrt{32}$

COURSE:	DDGT 120
INVENTOR DRAWING NAME:	CASTER
FIG #:	9-51
DRAFTER:	A KUYKENDALL
DATE:	11/9/2015
SCALE:	AS NOTED
PAGE #:	1 OF 2

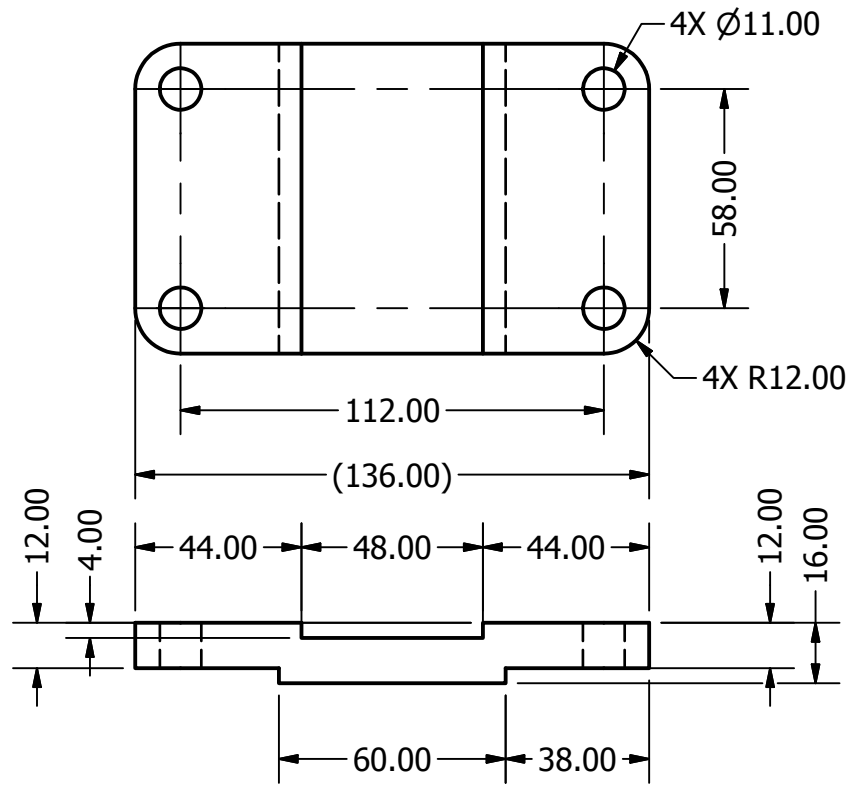

TOP PLATE  
SCALE 1 / 2

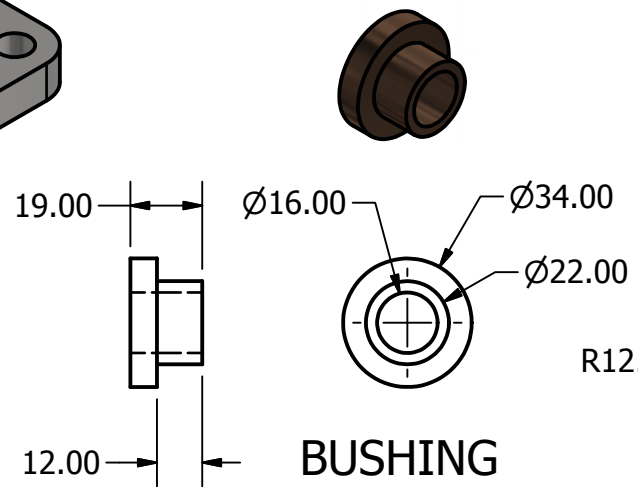
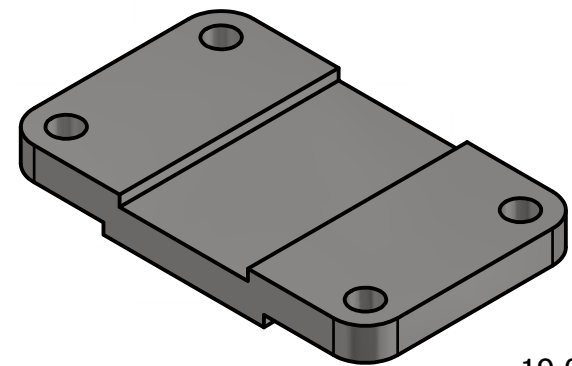

BUSHING  
SCALE 1 / 2

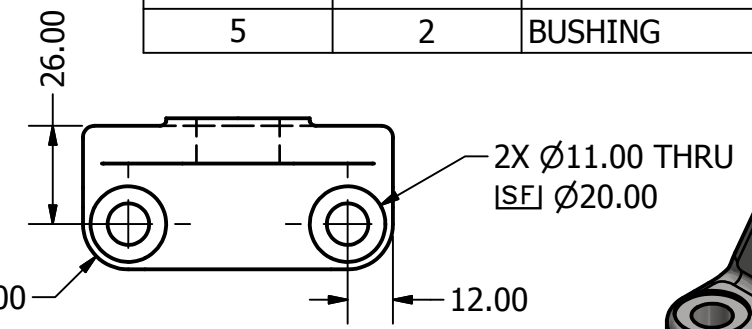

AXLE SUPPORT  
SCALE 1 / 2

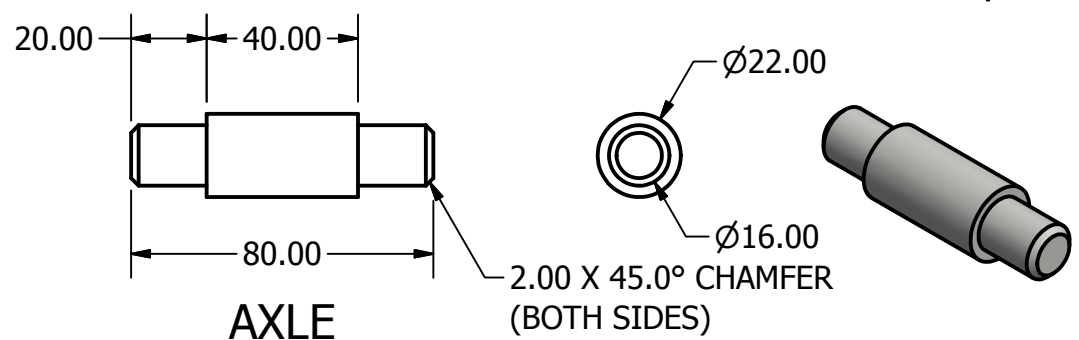
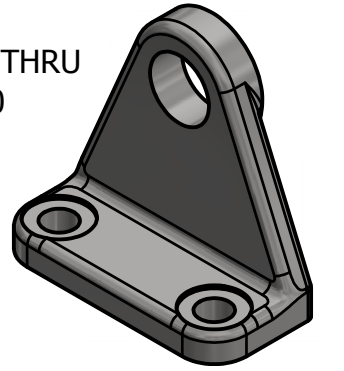

AXLE  
SCALE 1 / 2

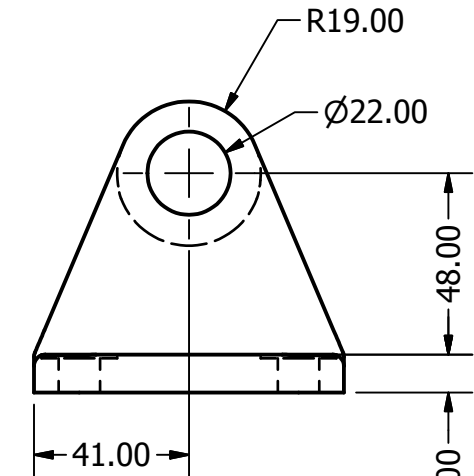
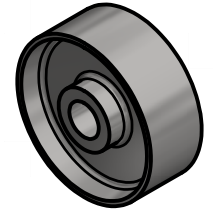

AXLE SUPPORT  
SCALE 1 / 2

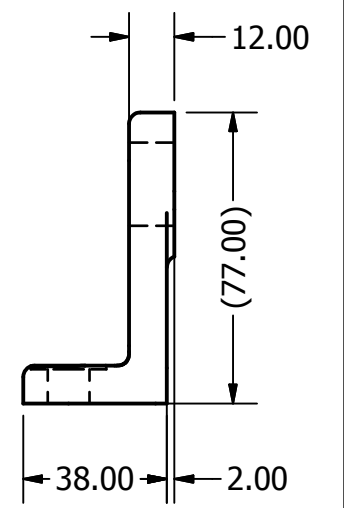

ROUNDS AND FILLETS R3

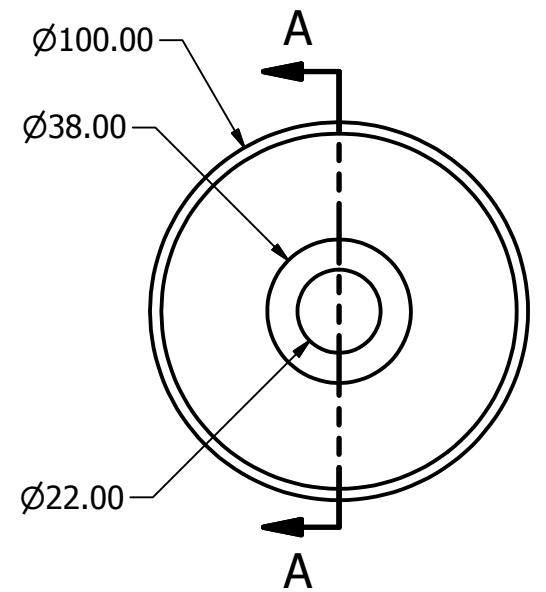

WHEEL  
SCALE 1 / 2

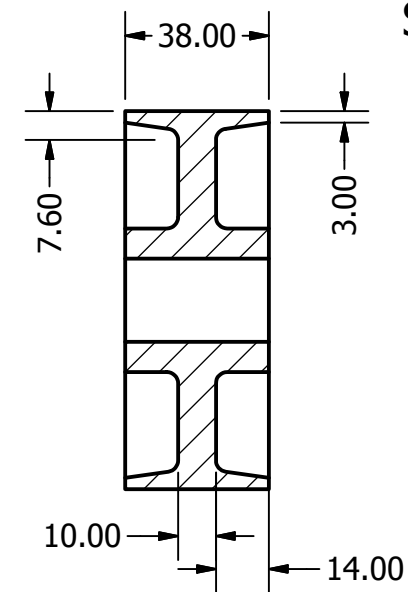

SECTION A-A  
SCALE 1 / 2

PARTS LIST		
ITEM	QTY	PART NUMBER
1	1	TOP PLATE
2	1	WHEEL
3	2	AXLE SUPPORT
4	1	AXLE
5	2	BUSHING



DIGITAL DESIGN  
GRAPHICS  
TECHNOLOGY

WWW.DDGT.NET



Alexzander Kuykendall

Draftsman and Graphic Designer

(707) 980-5920

alexjkuykendall@gmail.com

www.ddgt.net/StudentPages/akuykendall

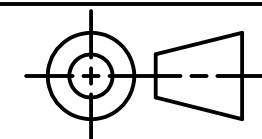

TOLERANCES UNLESS SPECIFIED  
MILIMETERS:  
WHOLE NUMBERS = ±.5  
X = ±.25  
XX = ±.12  
ANGLES ± 1 DEGREE

SURFACES 32 ✓

COURSE: DDGT 120

INVENTOR DRAWING NAME:

CASTER

FIG #: 9-51

DRAFTER: A KUYKENDALL

DATE: 11/9/2015

SCALE: AS NOTED

PAGE #: 2 OF 2