

PARTS LIST		
ITEM	QTY	PART NUMBER
1	1	DRILL PRESS BRACKET



DIGITAL DESIGN
GRAPHICS
TECHNOLOGY

WWW.DDGT.NET

GENERAL NOTES

ALL FILLETS AND
ROUNDS RE TO BE 1/8 R
UNLESS OTHERWISE
SPECIFIED.
MATERIAL TO BE
DETERMINED
BY MANUFACTURER.

LEGEND:

- ∅ DIAMETER
- R RADIUS
- ° DEGREE

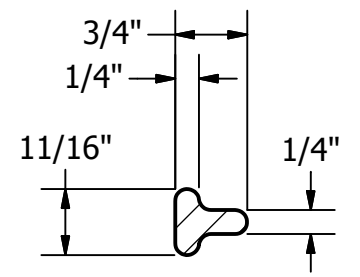

SECTION D-D
SCALE 1 / 2

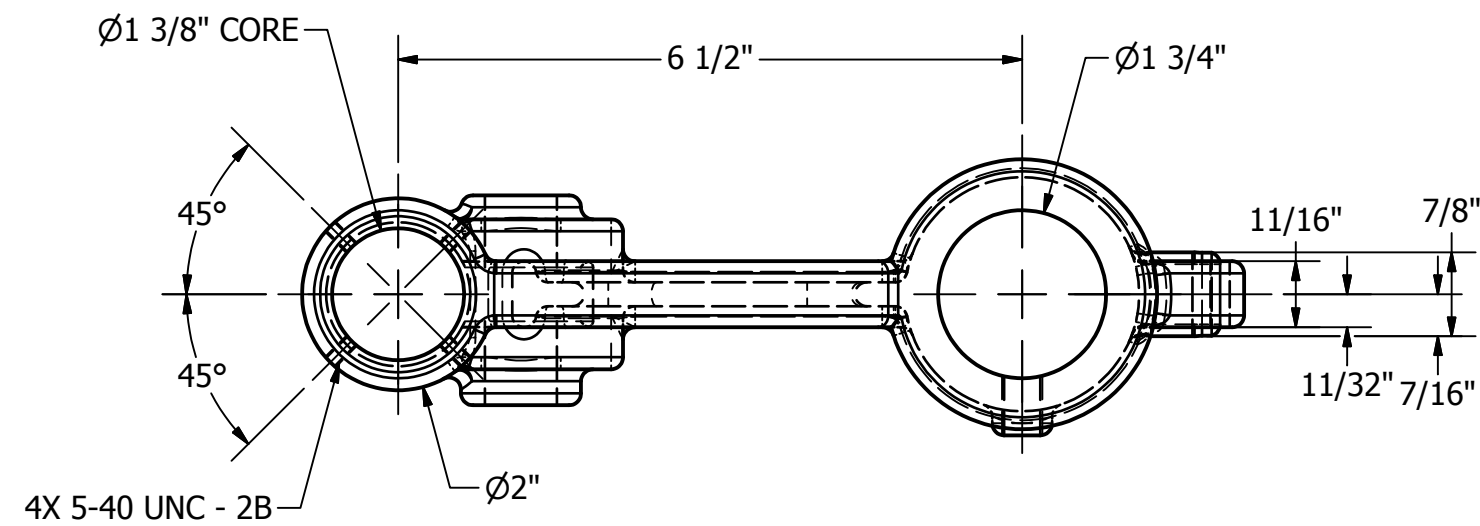

DRILL PRESS BRACKET
SCALE 1 / 2

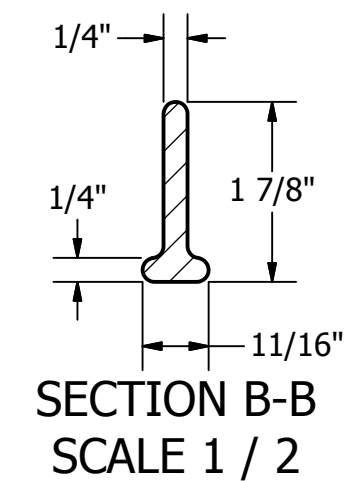
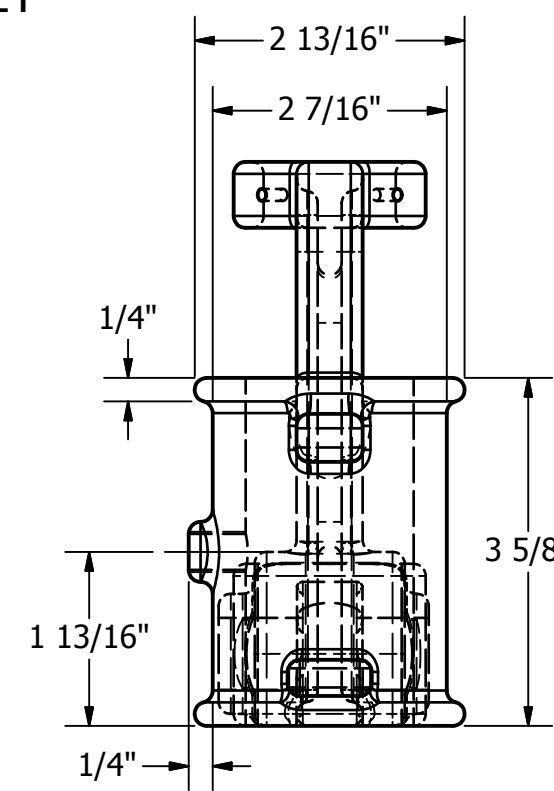
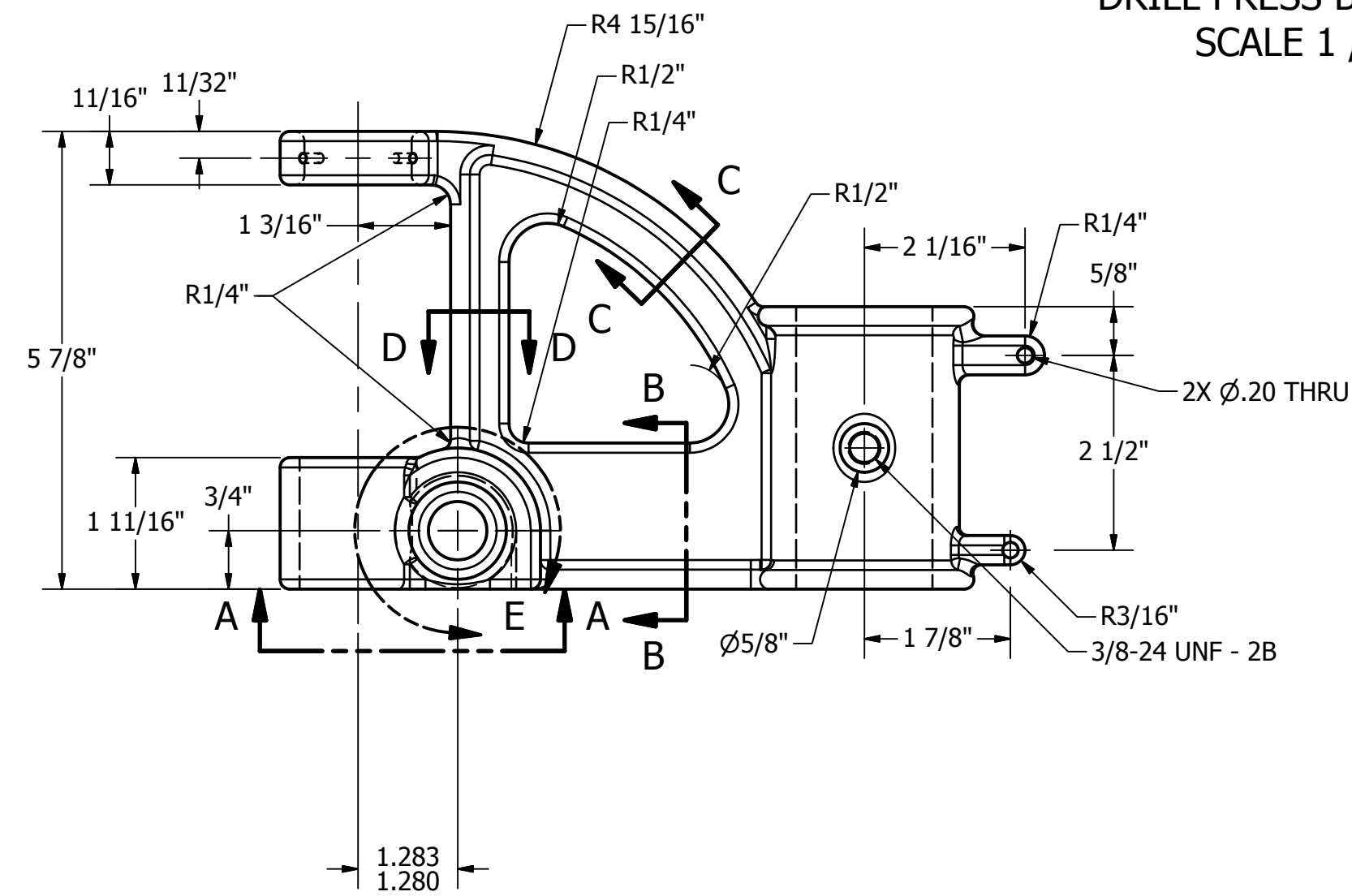
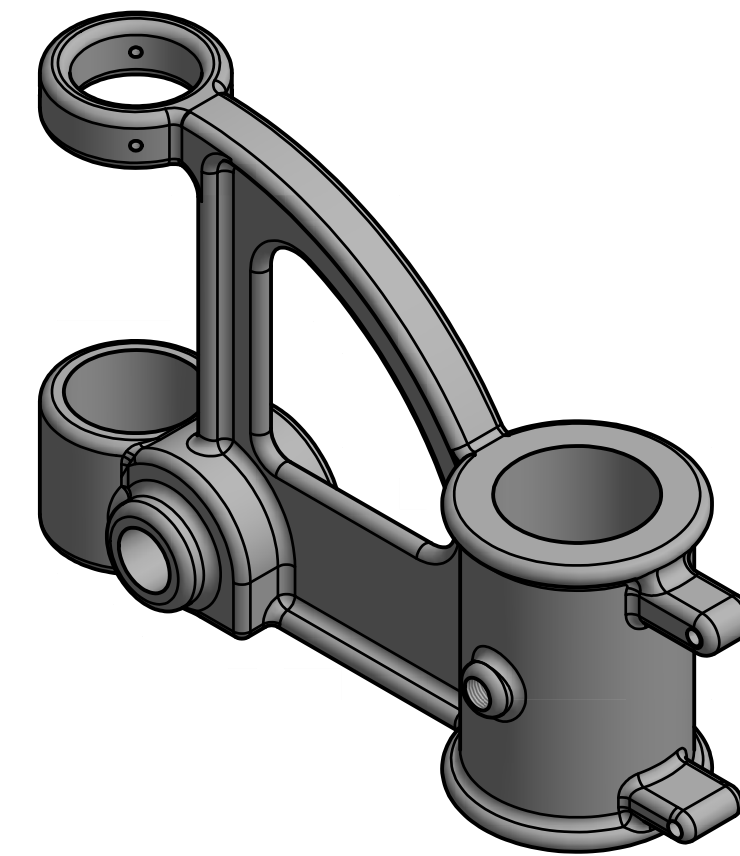

SECTION B-B
SCALE 1 / 2

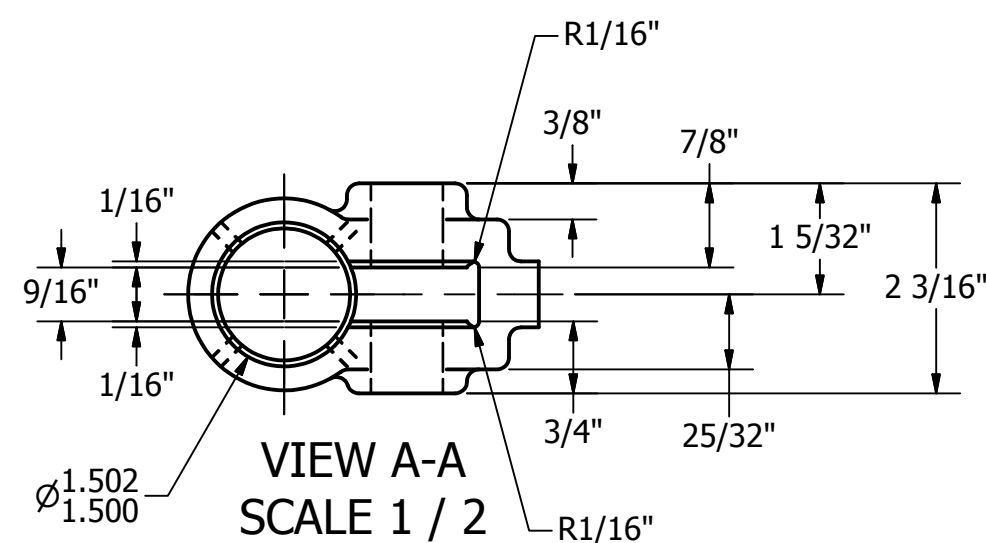

VIEW A-A
SCALE 1 / 2

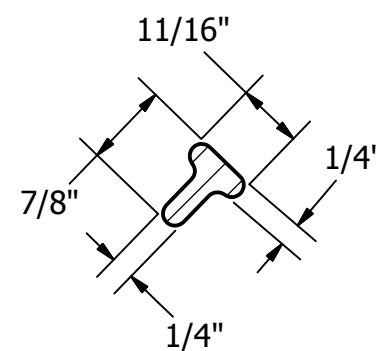

SECTION C-C
SCALE 1 / 2

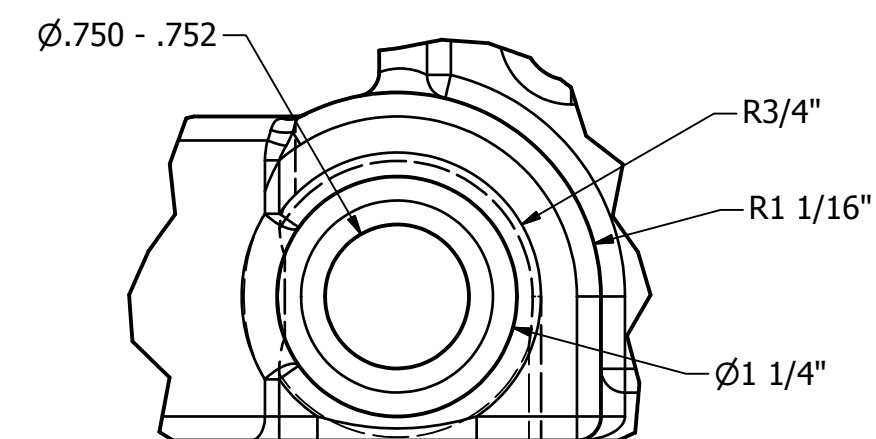

DETAIL E
SCALE 1 : 1

Alexander Kuykendall
Draftsman and Graphic Designer
(707) 980-5920
alexkuykendall@gmail.com
www.ddgt.net/StudentPages/akuykendall

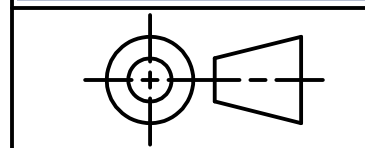

TOLERANCES UNLESS SPECIFIED
DECIMAL INCHES:
X = ±.020
XX = ±.010
XXX = ±.005
FRACTIONAL ± 1/64"
ANGLES ± 1 DEGREE
SURFACES 32

COURSE: DDGT 121

INVENTOR DRAWING NAME:

DRILL PRESS BRACKET

FIG #: 14-53

DRAFTER: A. KUYKENDALL

DATE: 3/1/2016

SCALE: AS NOTED

PAGE #: 1 OF 1