

TROLLEY EXPLODED ASSEMBLY
SCALE 1/6

PARTS LIST				
ITEM	QTY	PART NUMBER	MATERIAL	DESCRIPTION
1	2	SIDE PLATE ASSEMBLY		
1.1	1	SIDE PLATE	STEEL, MILD	
1.2	1	GUIDE	IRON, CAST	
1.3	2	RIVET BUTTON HEAD	STAINLESS STEEL	ø10 X 60 LG
2	4	WHEEL AXLE	STEEL AISI 1020 107 HR	
3	4	WHEEL	IRON, CAST	
4	6	COTTER PIN	STAINLESS STEEL	ø6 X 40 LG
5	44	ROLLER BEARING	STEEL AISI 1020 107 HR	
6	4	WASHER	STAINLESS STEEL	26 ID X 65 OD X 3 THK
7	12	ADJUSTING WASHER	STAINLESS STEEL	26 ID X 44 OD X 4 THK
8	4	LOCKNUT	STAINLESS STEEL	M16 X 2 PREVAILING TORQUE INSERT-TYPE
9	1	AXLE	COLD ROLLED STEEL	
10	1	HOOK PLATE	STAINLESS STEEL	

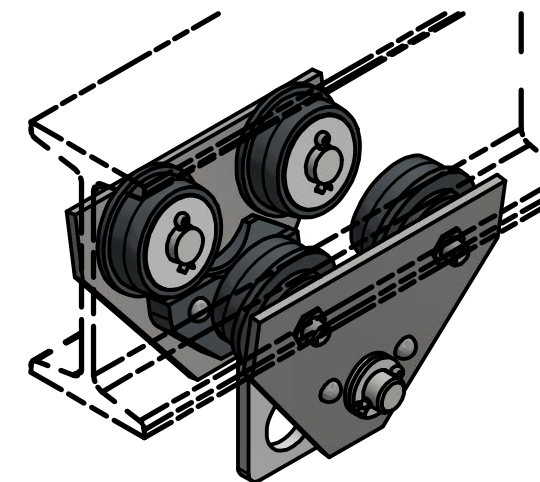

TROLLEY ASSEMBLY
SCALE 1 / 5

METRIC

LEGEND:

- ∅ DIAMETER
- R RADIUS
- ° DEGREE

GENERAL NOTES:

TROLLEY TO BE MOUNTED ONTO A S200 X 34 BEAM.



DIGITAL DESIGN
GRAPHICS
TECHNOLOGY

WWW.DDGT.NET



Alexzander Kuykendall

Draftsman and Graphic Designer

(707) 980-5920

alexjkuykendall@gmail.com

www.ddgt.net/StudentPages/akuykendall

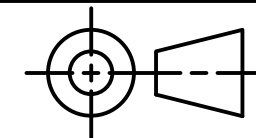

TOLERANCES UNLESS SPECIFIED

MILIMETERS:

WHOLE NUMBERS = ±.5

X = ±.25

XX = ±.12

ANGLES ± 1 DEGREE

SURFACES $\sqrt{32}$

COURSE: DDGT 120

INVENTOR DRAWING NAME:

TROLLEY

FIG #: 14-83

DRAFTER: A. KUYKENDALL

DATE: 11/30/2015

SCALE: AS NOTED

PAGE #: 1 OF 5

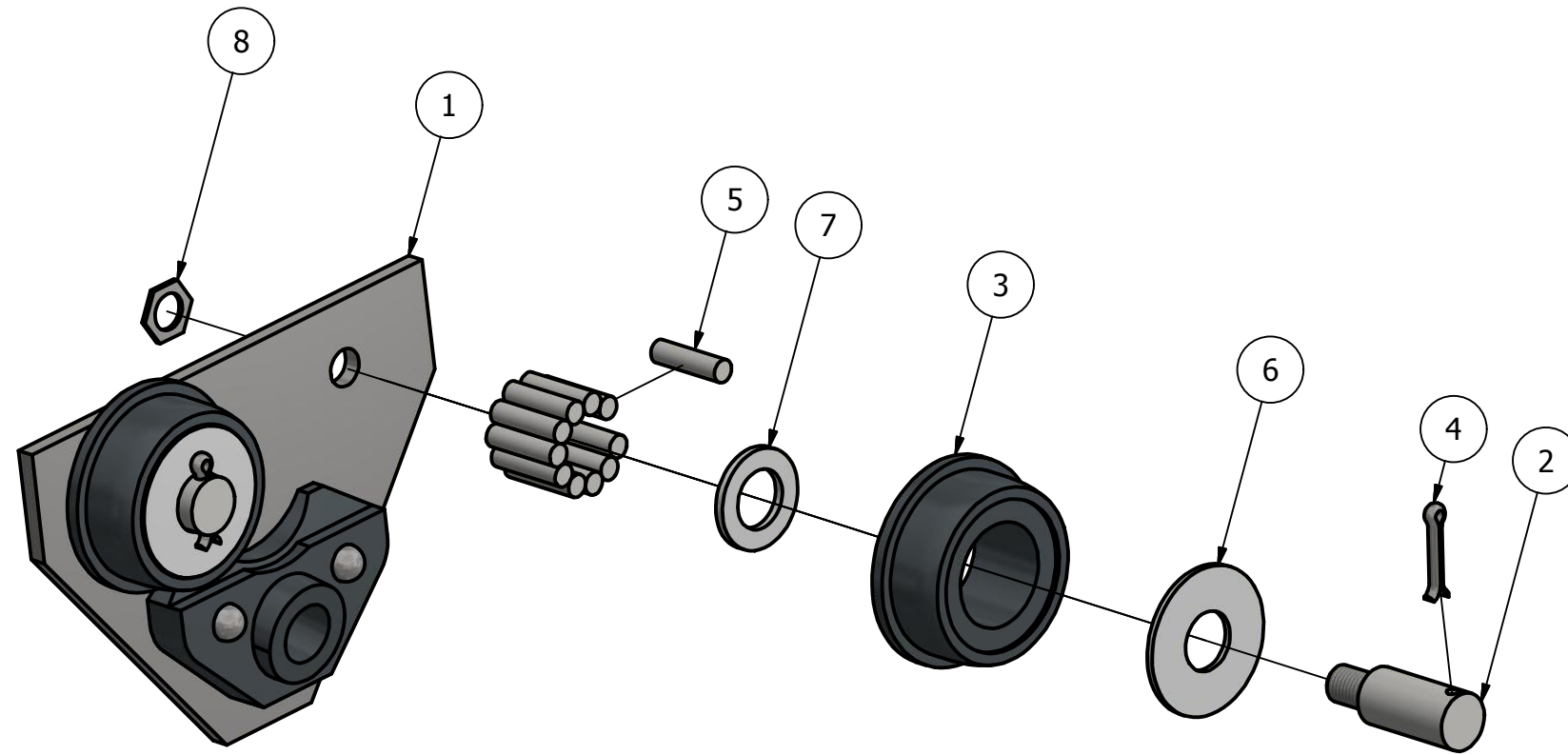

EXPLODED WHEEL ASSEMBLY
SCALE 1 / 3

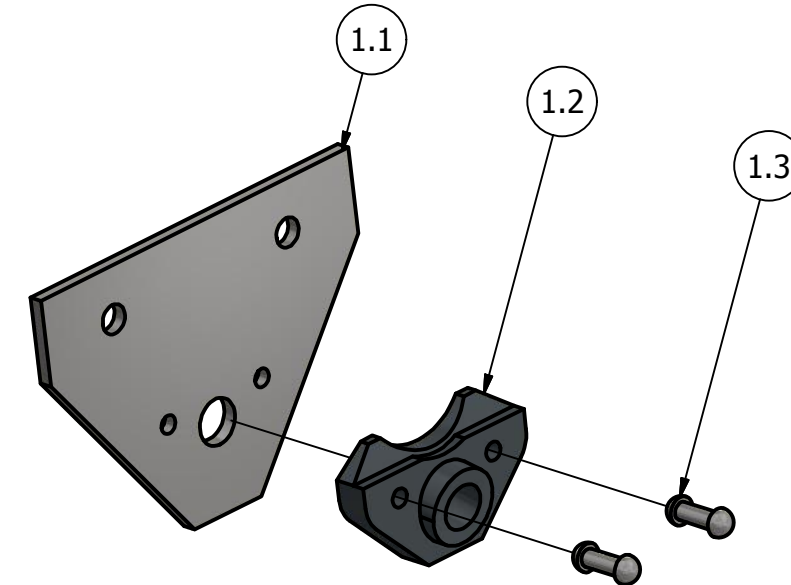

SIDE PLATE ASSEMBLY
SCALE 1 / 4

PARTS LIST		
ITEM	QTY	PART NUMBER
1	2	SIDE PLATE ASSEMBLY
1.1	1	SIDE PLATE
1.2	1	GUIDE
1.3	2	RIVET BUTTON HEAD
2	4	WHEEL AXLE
3	4	WHEEL
4	6	COTTER PIN
5	44	ROLLER BEARING
6	4	WASHER
7	12	ADJUSTING WASHER
8	4	LOCKNUT
10	1	HOOK PLATE

DDGT

DIGITAL DESIGN
GRAPHICS
TECHNOLOGY

WWW.DDGT.NET



Alexzander Kuykendall

Draftsman and Graphic Designer

(707) 980-5920

alexjkuykendall@gmail.com

www.ddgt.net/StudentPages/akuykendall

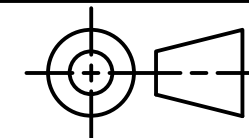

TOLERANCES UNLESS SPECIFIED

MILIMETERS:

WHOLE NUMBERS = $\pm .5$

X = $\pm .25$

XX = $\pm .12$

ANGLES ± 1 DEGREE

SURFACES $\sqrt{32}$

COURSE: DDGT 120

INVENTOR DRAWING NAME:

TROLLEY

FIG #: 14-83

DRAFTER: A. KUYKENDALL

DATE: 11/30/2015

SCALE: AS NOTED

PAGE #: 2 OF 5

PARTS LIST		
ITEM	QTY	PART NUMBER
1.1	2	SIDE PLATE
10	1	HOOK PLATE

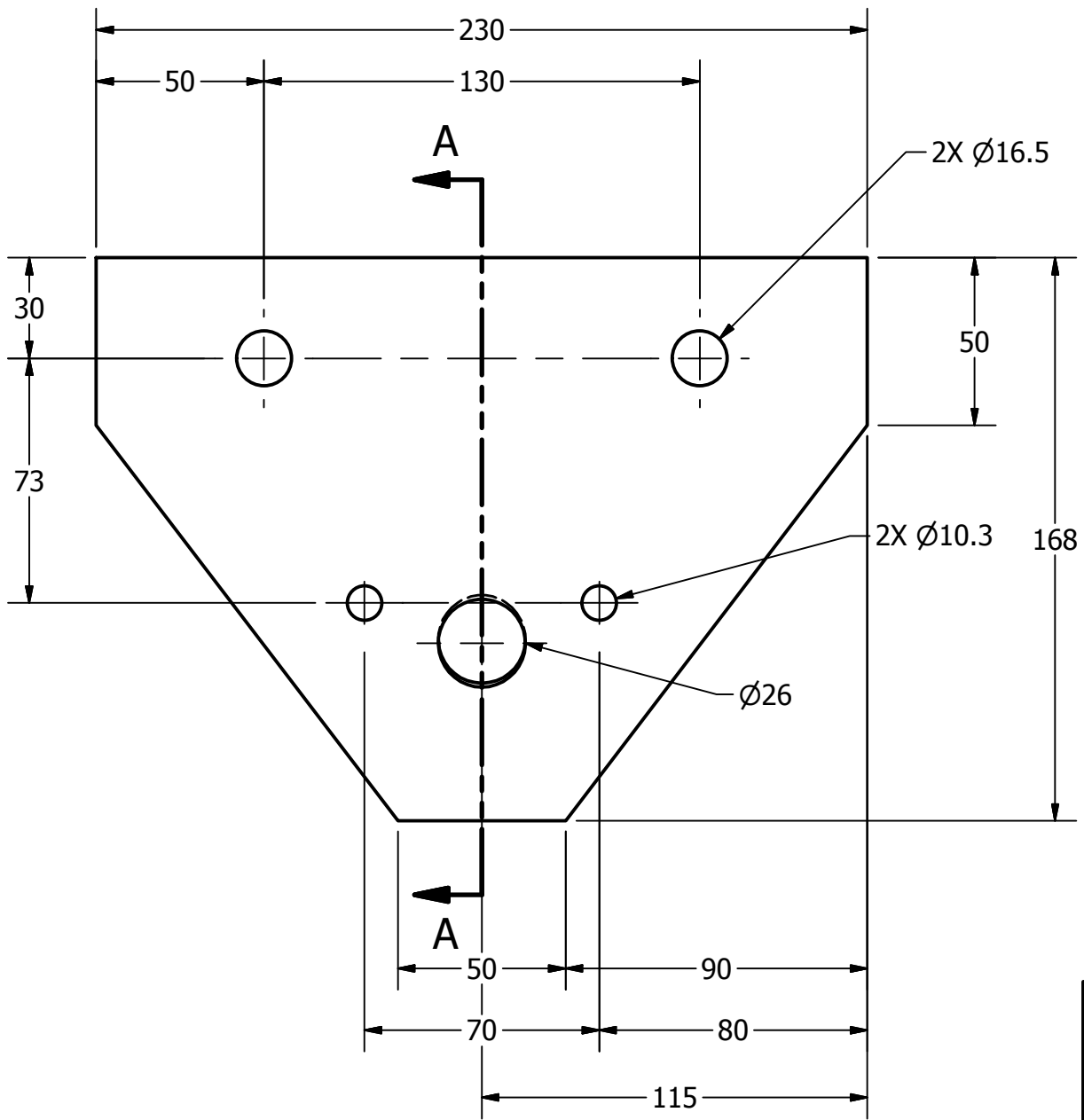

SIDE PLATE
SCALE 1 / 2

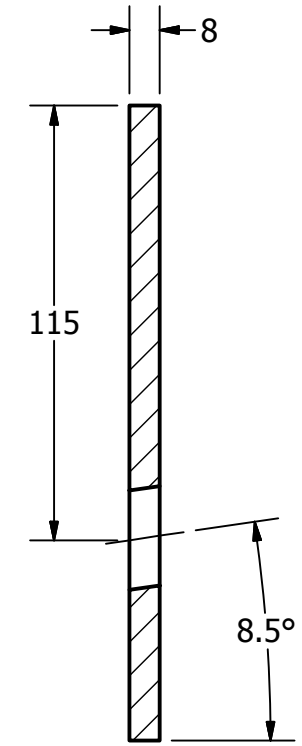
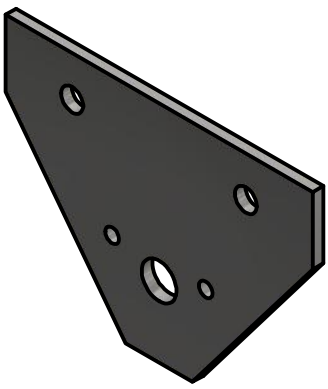

SECTION A-A
SCALE 1 / 2

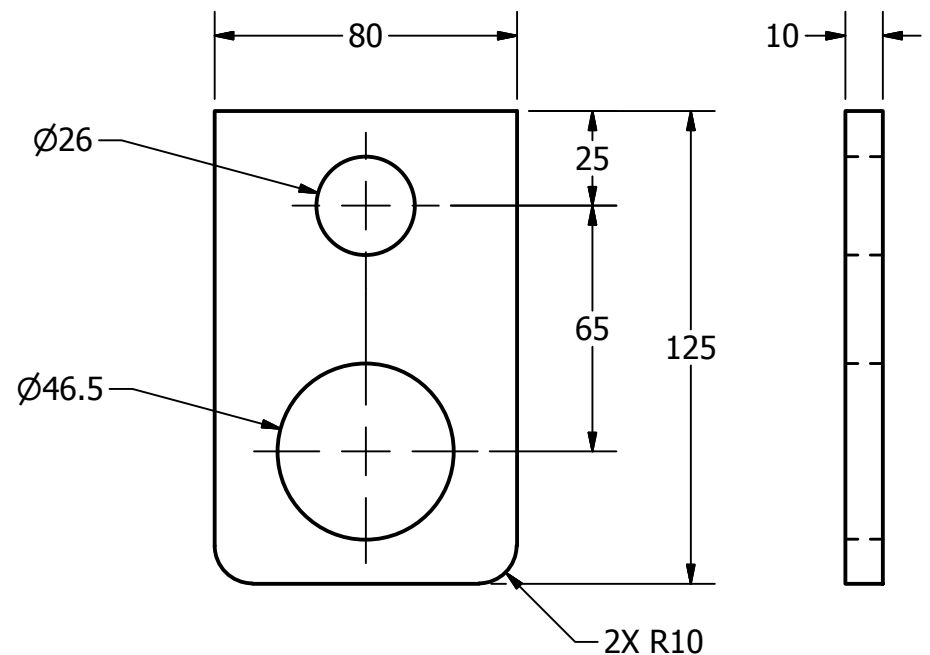
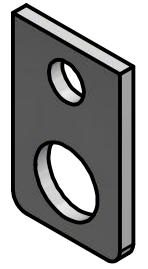

HOOK PLATE
SCALE 1 / 2

DDGT
DIGITAL DESIGN
GRAPHICS
TECHNOLOGY
WWW.DDGT.NET

Alexzander Kuykendall
Draftsman and Graphic Designer
(707) 980-5920
alexjkuykendall@gmail.com
www.ddgt.net/StudentPages/akuykendall

TOLERANCES UNLESS SPECIFIED
MILIMETERS:
WHOLE NUMBERS = ±.5
X = ±.25
XX = ±.12
ANGLES ± 1 DEGREE
SURFACES $\sqrt{32}$

COURSE:	DDGT 120
INVENTOR DRAWING NAME:	TROLLEY
FIG #:	14-83
DRAFTER:	A. KUYKENDALL
DATE:	11/30/2015
SCALE:	AS NOTED
PAGE #:	3 OF 5

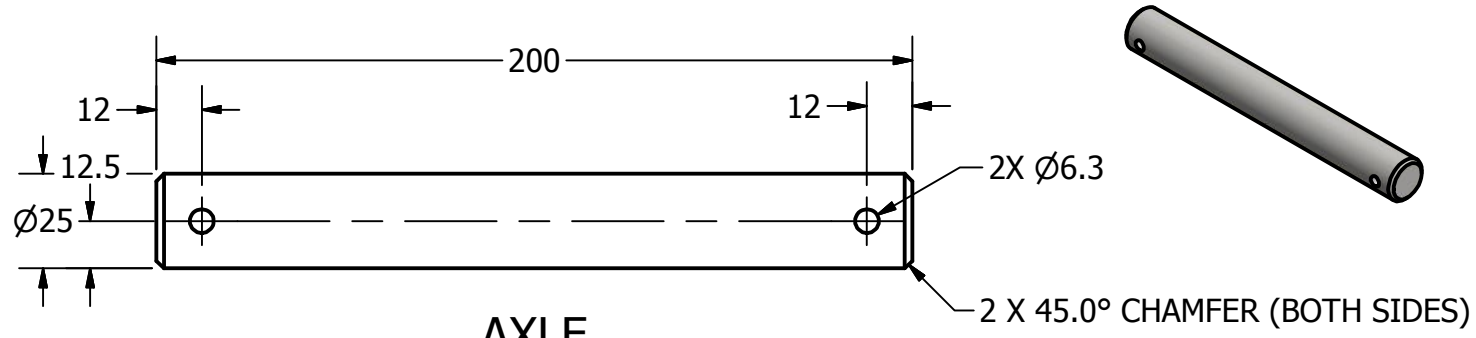

AXLE
SCALE 1 / 2

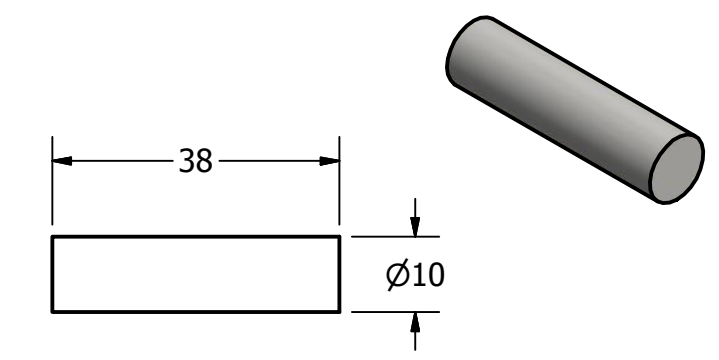

ROLLER BEARING
SCALE 1 : 1

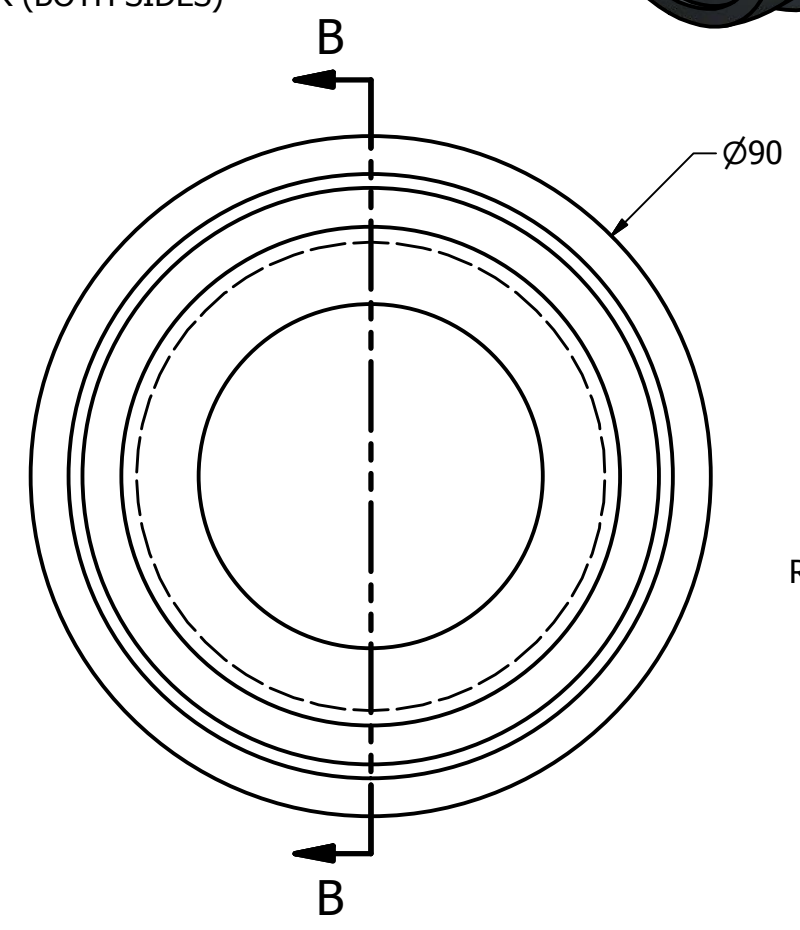

WHEEL
SCALE 1 : 1

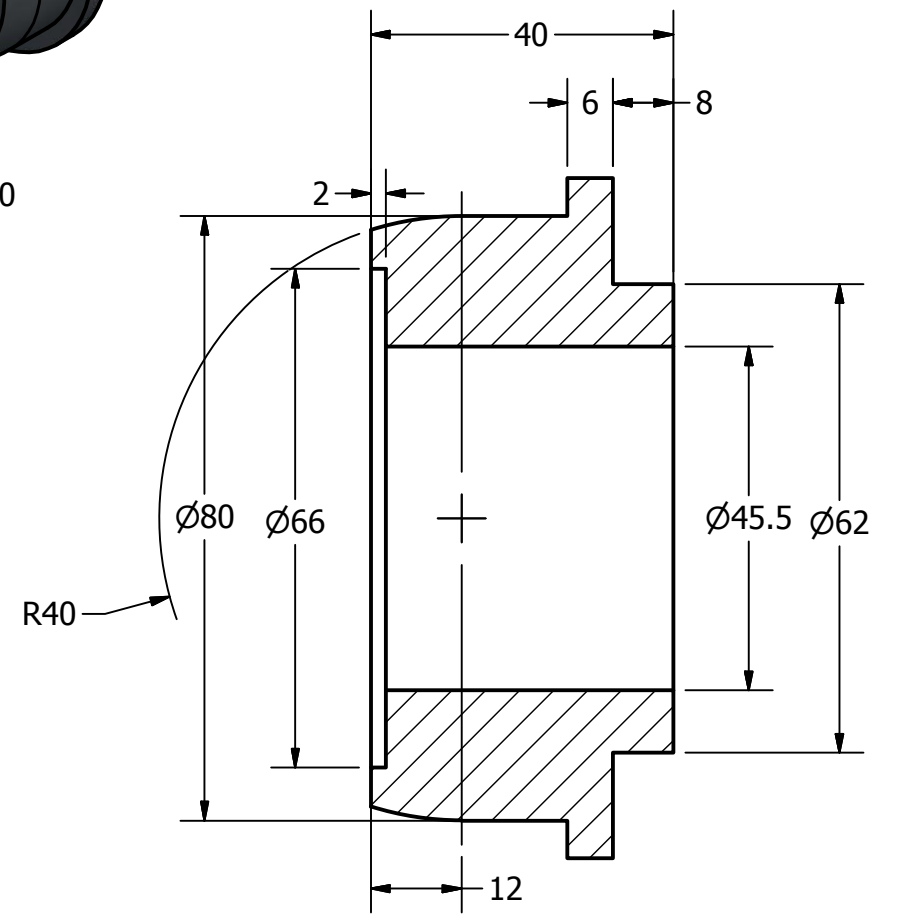

SECTION B-B
SCALE 1 : 1

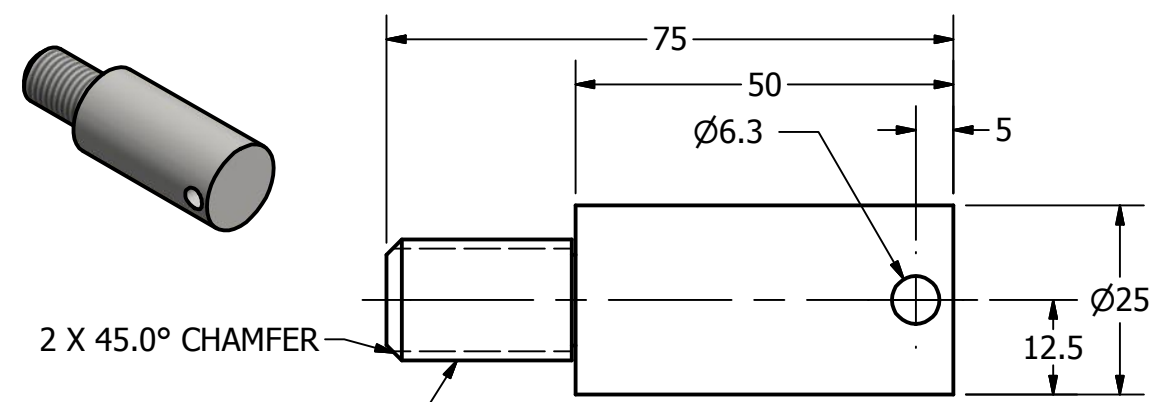

WHEEL AXLE
SCALE 1 : 1

PARTS LIST		
ITEM	QTY	PART NUMBER
2	4	WHEEL AXLE
3	4	WHEEL
5	44	ROLLER BEARING
9	1	AXLE

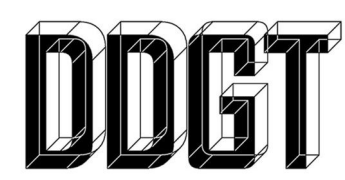

DIGITAL DESIGN
GRAPHICS
TECHNOLOGY

WWW.DDGT.NET



Alexzander Kuykendall

Draftsman and Graphic Designer

(707) 980-5920

alexjkuykendall@gmail.com

www.ddgt.net/StudentPages/akuykendall

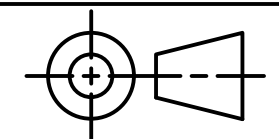

TOLERANCES UNLESS SPECIFIED
MILIMETERS:
WHOLE NUMBERS = ±.5
X = ±.25
XX = ±.12
ANGLES ± 1 DEGREE

SURFACES 32 ✓

COURSE: DDGT 120

INVENTOR DRAWING NAME:

TROLLEY

FIG #: 14-83

DRAFTER: A. KUYKENDALL

DATE: 11/30/2015

SCALE: AS NOTED

PAGE #: 4 OF 5

PARTS LIST		
ITEM	QTY	PART NUMBER
1.2	2	GUIDE

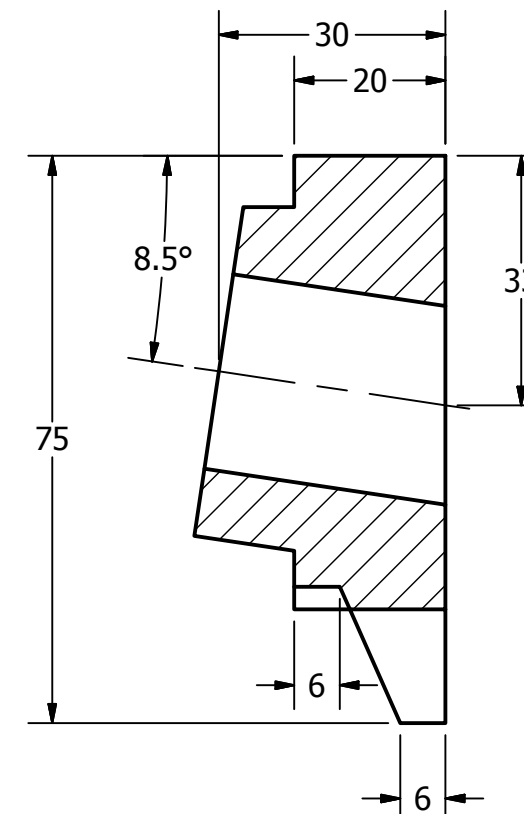
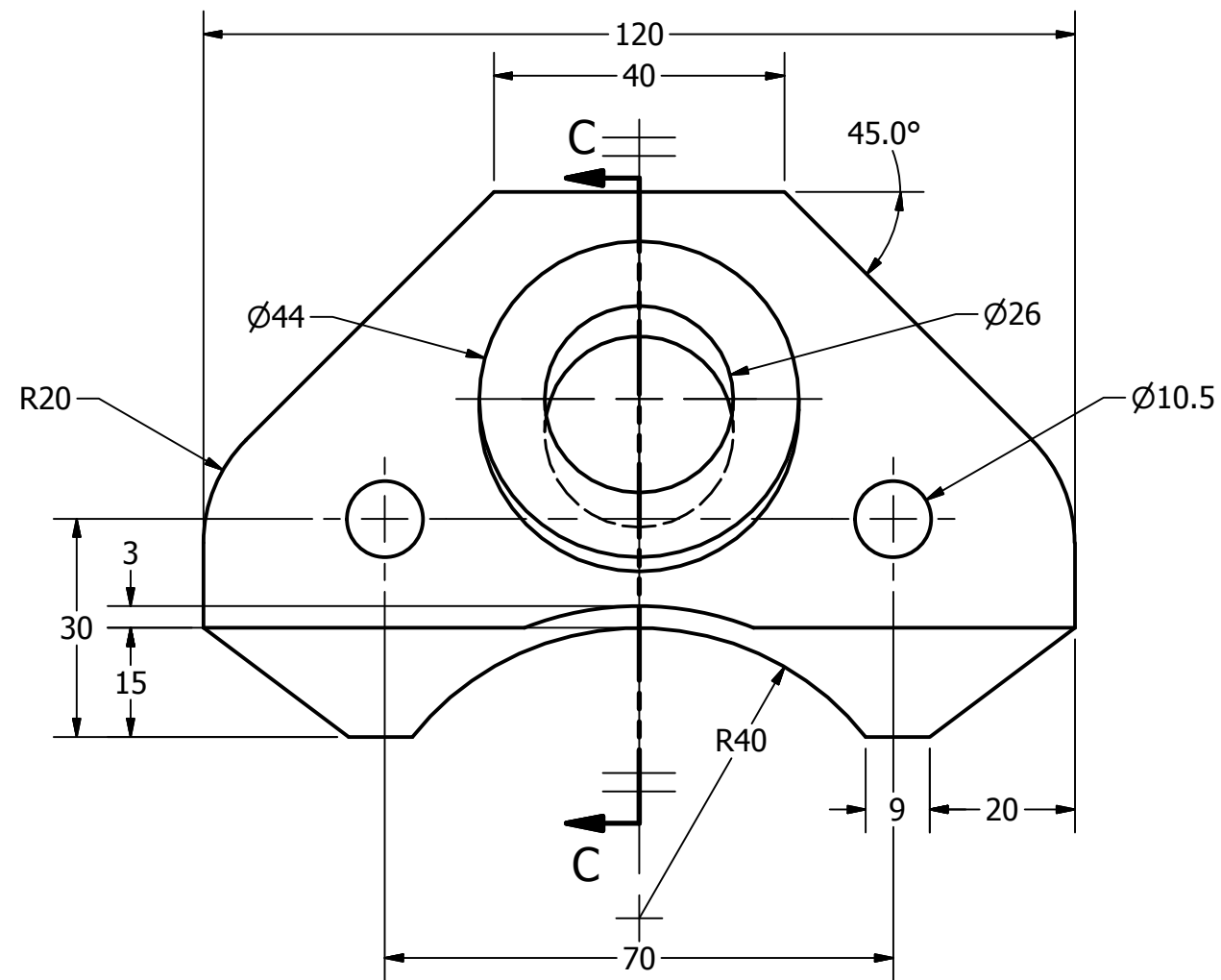
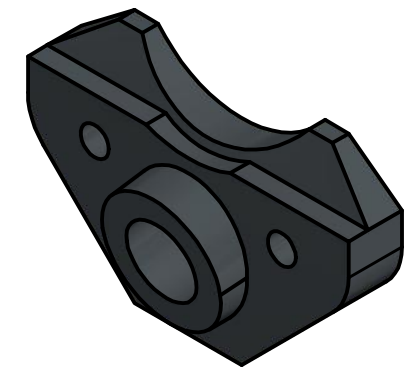

SECTION C-C
SCALE 1 : 1

GUIDE
SCALE 1 : 1

DDGT
DIGITAL DESIGN
GRAPHICS
TECHNOLOGY
WWW.DDGT.NET

Alexzander Kuykendall
Draftsman and Graphic Designer
(707) 980-5920
alexjkuykendall@gmail.com
www.ddgt.net/StudentPages/akuykendall

TOLERANCES UNLESS SPECIFIED
MILIMETERS:
WHOLE NUMBERS = ±.5
X = ±.25
XX = ±.12
ANGLES ± 1 DEGREE
SURFACES $\sqrt{32}$

COURSE:	DDGT 120
INVENTOR DRAWING NAME:	TROLLEY
FIG #:	14-83
DRAFTER:	A. KUYKENDALL
DATE:	11/30/2015
SCALE:	AS NOTED
PAGE #:	5 OF 5