

PARTS LIST			
ITEM	QTY	PART NUMBER	DESCRIPTION
1	1	AXLE	
2	1	COLLAR	
3	1	FRAME	
4	1	OILLESS BUSHING	
5	1	WHEEL	
6	2	SIDE PLATE	
7	2	WASHER	
8	6	RIVET	Ø.31 RIVETS EQUALLY SPACED
9	1	ANSI B18.8.2 - 1/4 x 1 7/8 STANDARD DUTY	PIN - COILED SPRING

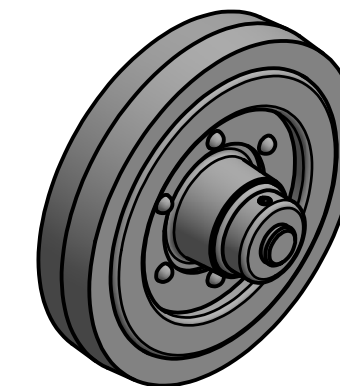

WHEEL ASSEMBLY  
SCALE 1 / 4

**LEGEND:**

- ∅ DIAMETER
- R RADIUS
- ° DEGREE

EXPLODED WHEEL ASSEMBLY  
SCALE 1 / 4

GENERAL NOTES: MATERIALS TO BE DECIDED BY MANUFACTURER.  
ALL FILLETS ARE .12



DIGITAL DESIGN  
GRAPHICS  
TECHNOLOGY

WWW.DDGT.NET



Alexzander Kuykendall

Draftsman and Graphic Designer

(707) 980-5920

alexjkuykendall@gmail.com

www.ddgt.net/StudentPages/akuykendall

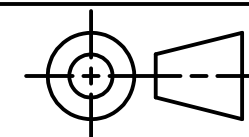

TOLERANCES UNLESS SPECIFIED

DECIMAL INCHES:

X = ±.020

XX = ±.010

XXX = ±.005

FRACTIONAL ± 1/64"

ANGLES ± 1 DEGREE

SURFACES  $\sqrt{32}$

COURSE: DDGT 121

INVENTOR DRAWING NAME:

WHEEL ASSEMBLY

FIG #: 11-55

DRAFTER: A. KUYKENDALL

DATE: 2/11/2016

SCALE: AS NOTED

PAGE #: 1 OF 2

PARTS LIST		
ITEM	QTY	PART NUMBER
1	1	AXLE
2	1	COLLAR
3	1	FRAME
4	1	OILLESS BUSHING
5	1	WHEEL
6	2	SIDE PLATE
7	2	WASHER
8	6	RIVET
9	1	ANSI B18.8.2 - 1/4 x 1 7/8 STANDARD DUTY

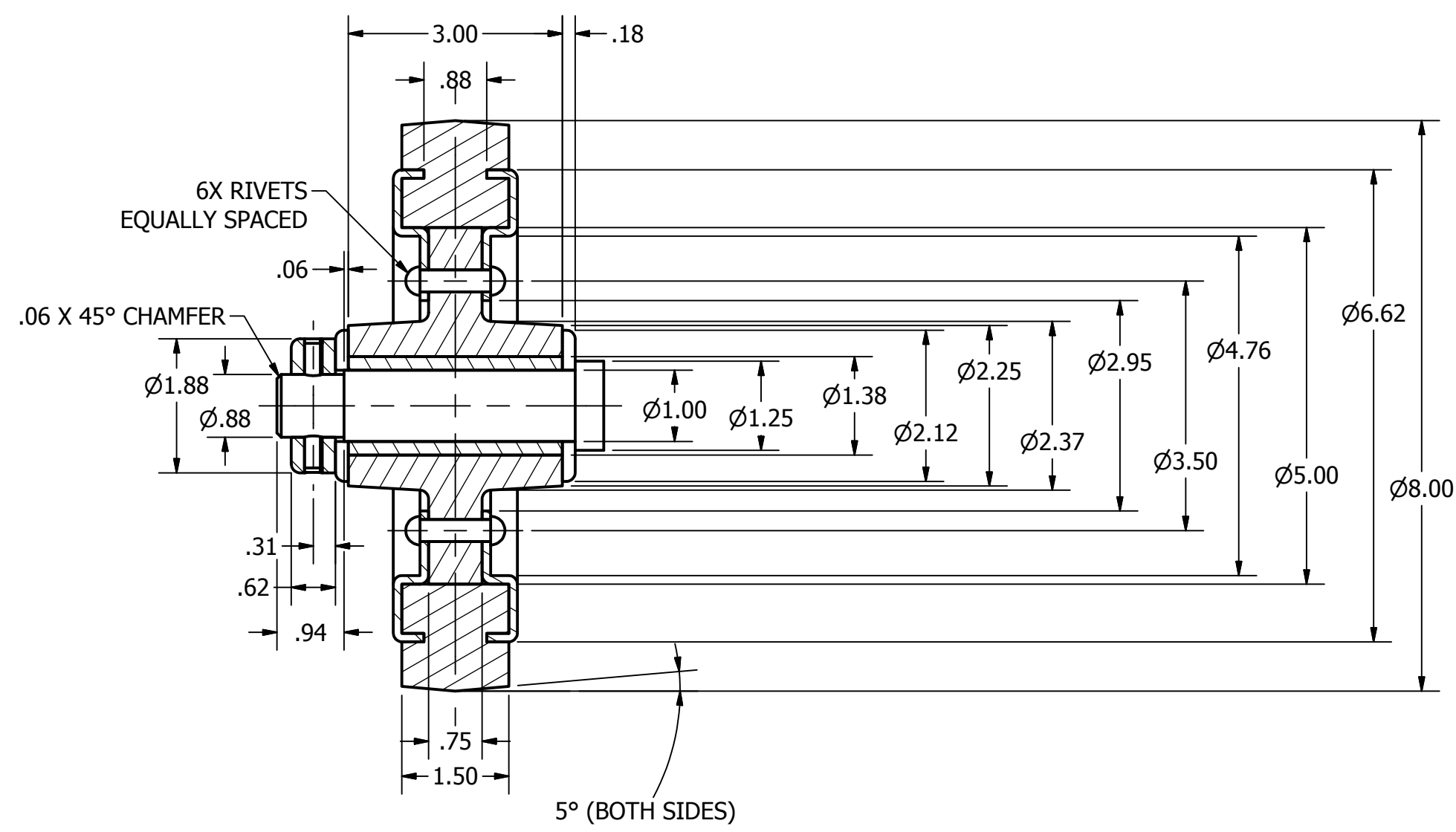

WHEEL ASSEMBLY  
SCALE 1 / 2

**DDGT**  
DIGITAL DESIGN  
GRAPHICS  
TECHNOLOGY  
WWW.DDGT.NET

Alexzander Kuykendall  
Draftsman and Graphic Designer  
(707) 980-5920  
alexjkuykendall@gmail.com  
[www.ddgt.net/StudentPages/akuykendall](http://www.ddgt.net/StudentPages/akuykendall)

TOLERANCES UNLESS SPECIFIED  
DECIMAL INCHES:  
X = ±.020  
XX = ±.010  
XXX = ±.005  
FRACTIONAL ± 1/64"  
ANGLES ± 1 DEGREE  
SURFACES 32 ✓

COURSE:	DDGT 121
INVENTOR DRAWING NAME:	WHEEL ASSEMBLY
FIG #:	11-55
DRAFTER:	A. KUYKENDALL
DATE:	2/11/2016
SCALE:	AS NOTED
PAGE #:	2 OF 2