



DIGITAL DESIGN
GRAPHICS
TECHNOLOGY

WWW.DDGT.NET

PARTS LIST

ITEM	QTY	PART NUMBER	MATERIAL	DESCRIPTION
1	2	SIDE PLATE SUB-ASSEMBLY		
1.1	1	SIDE PLATE	MILD STEEL	
1.2	1	GUIDE	CAST IRON	
1.3	2	RIVET	STANDARD	BUTTON HEAD, Ø10 X 60 LONG
2	1	AXLE	COLD ROLLED STEEL	
3	1	HOOK	MILD STEEL	10 THICK
4	44	ROLLER BEARING	COLD ROLLED STEEL	Ø10 X 38 LONG
5	4	WHEEL	CAST IRON	
6	4	WHEEL AXLE	COLD ROLLED STEEL	
7	12	ADJUSTING WASHER	STANDARD	Ø26ID X Ø44OD X 4 THICK
8	4	WASHER	STANDARD	Ø26ID X Ø65OD X 3 THICK
9	4	LOCKNUT	STANDARD	M16 X 2 (PREVAILING TORQUE INSERT-TYPE)
10	6	COTTER PIN	STANDARD	Ø6 X 40 LONG

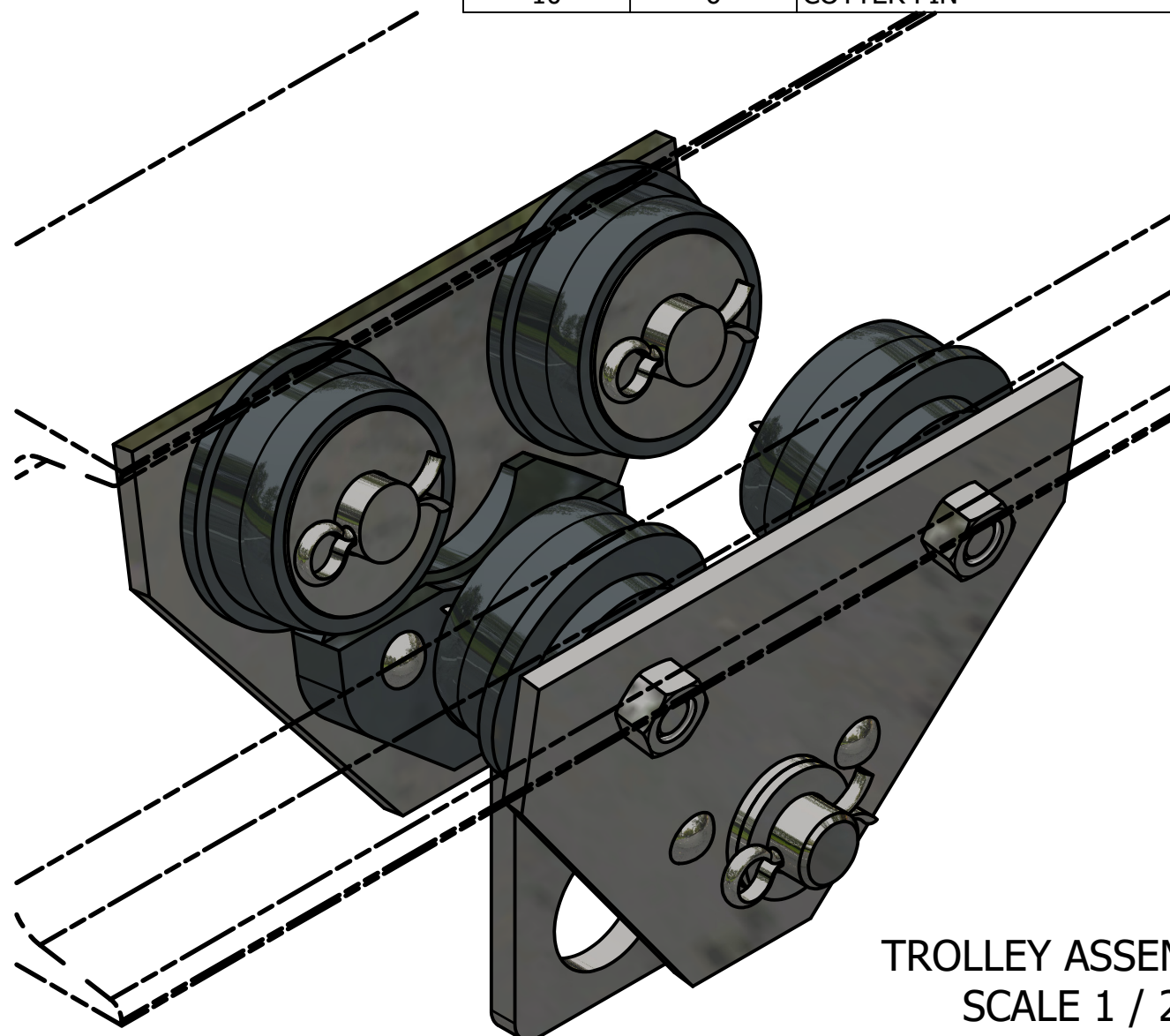

TROLLEY ASSEMBLY
SCALE 1 / 2

LEGEND:

- Ø DIAMETER
- R RADIUS
- ° DEGREES

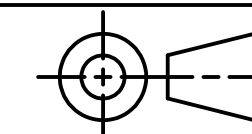

TOLERANCES UNLESS SPECIFIED:
MILLIMETERS:
WHOLE NUMBERS = ±.5
X = ±.010
XX = ±.005
FRACTIONAL ±1/64"
ANGLES ±1 DEGREE
SURFACES $\sqrt{\text{32}}$

GENERAL NOTES:

TROLLEY TO BE MOUNTED ON AN
S200 X 34 BEAM

ALL CHAMFER ARE 2 X 2 UNLESS OTHERWISE NOTED

CLASS:	DDGT 120
ASSIGNMENT #:	70
INVENTOR DRAWING NAME:	TROLLEY
FIG #:	14-83
MANAGER:	G. STROMMEN
DRAWN BY:	A. MOSTAFA
DATE:	12/5/2022
SCALE:	AS NOTED
PAGE #:	1 OF 6

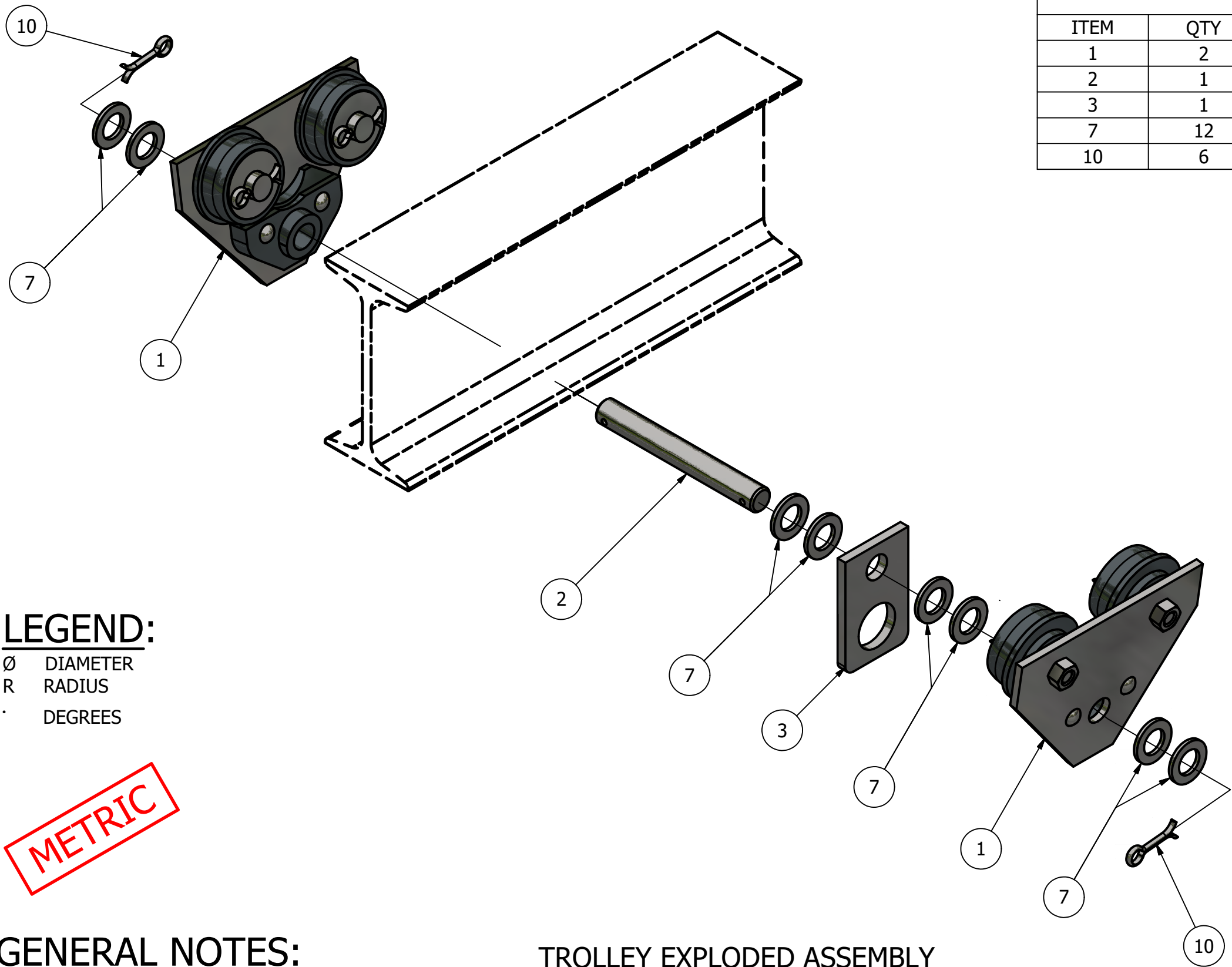

PARTS LIST		
ITEM	QTY	PART NUMBER
1	2	SIDE PLATE SUB-ASSEMBLY
2	1	AXLE
3	1	HOOK
7	12	ADJUSTING WASHER
10	6	COTTER PIN



DIGITAL DESIGN
GRAPHICS
TECHNOLOGY

WWW.DDGT.NET

LEGEND:

- ∅ DIAMETER
- R RADIUS
- ° DEGREES

METRIC

GENERAL NOTES:

TROLLEY TO BE MOUNTED ON AN
S200 X 34 BEAM

ALL CHAMFER ARE 2 X 2 UNLESS OTHERWISE NOTED

TROLLEY EXPLODED ASSEMBLY
SCALE 1 / 4

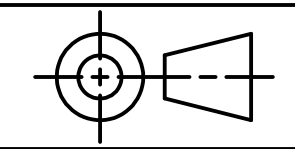

TOLERANCES UNLESS SPECIFIED:
MILLIMETERS:
WHOLE NUMBERS = ±.5
X = ±.010
XX = ±.005
FRACTIONAL ±1/64"
ANGLES ±1 DEGREE
SURFACES $\sqrt{\text{32}}$

CLASS: DDGT 120

ASSIGNMENT #: 70

INVENTOR DRAWING NAME:
TROLLEY

FIG #: 14-83

MANAGER: G. STROMMEN

DRAFTER: A. MOSTAFA

DATE: 12/5/2022

SCALE: AS NOTED

PAGE #: 2 OF 6

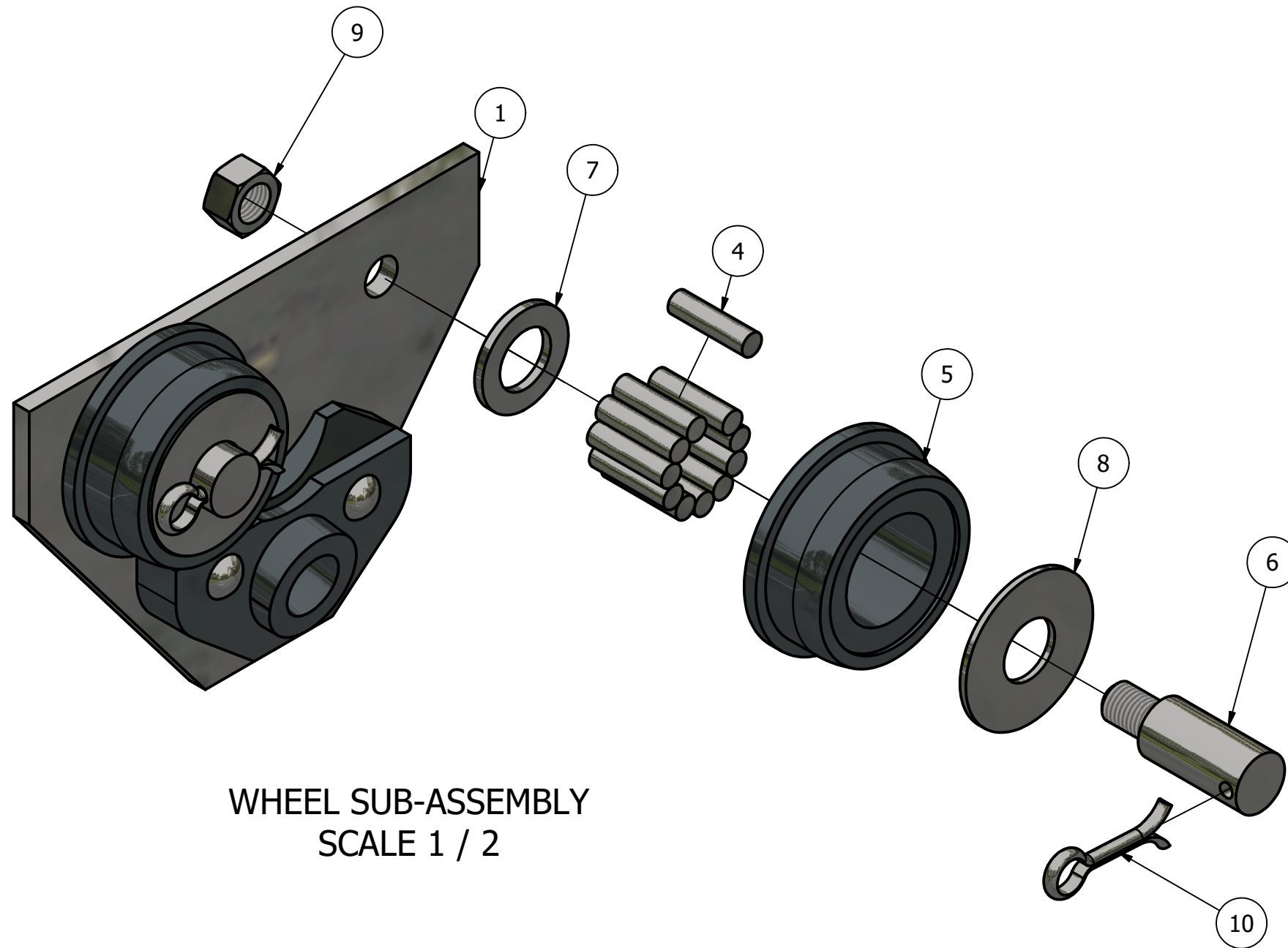

WHEEL SUB-ASSEMBLY
SCALE 1 / 2

GENERAL NOTES:

TROLLEY TO BE MOUNTED ON AN
S200 X 34 BEAM

ALL CHAMFER ARE 2 X 2 UNLESS OTHERWISE NOTED

METRIC

LEGEND:

- ∅ DIAMETER
- R RADIUS
- ° DEGREES

PARTS LIST		
ITEM	QTY	PART NUMBER
1.1	2	SIDE PLATE
1.2	2	GUIDE
1.3	4	RIVET
4	44	ROLLER BEARING
5	4	WHEEL
6	4	WHEEL AXLE
7	12	ADJUSTING WASHER
8	4	WASHER
9	4	LOCKNUT
10	6	COTTER PIN

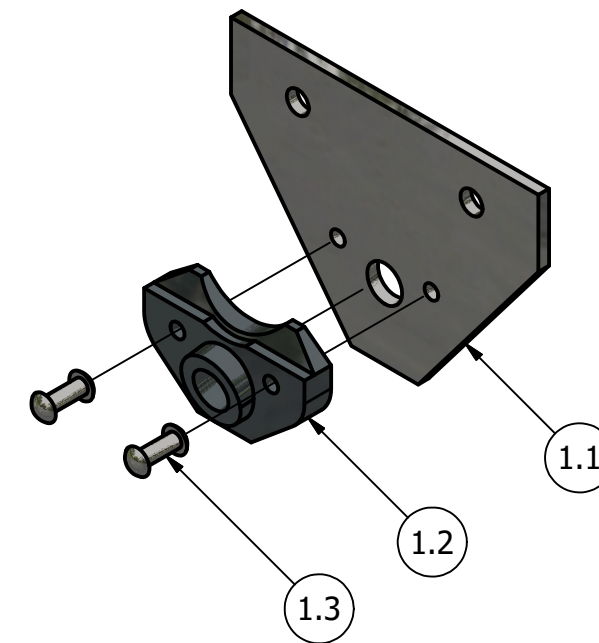

SIDE PLATE SUB-ASSEMBLY
SCALE 1 / 4



DIGITAL DESIGN
GRAPHICS
TECHNOLOGY

WWW.DDGT.NET

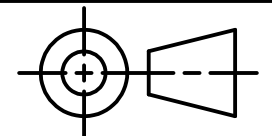

TOLERANCES UNLESS SPECIFIED:
MILLIMETERS:
WHOLE NUMBERS = ±.5
X = ±.010
XX = ±.005
FRACTIONAL ±1/64"
ANGLES ±1 DEGREE
SURFACES $\sqrt{\text{32}}$

CLASS: DDGT 120

ASSIGNMENT #: 70

INVENTOR DRAWING NAME:
TROLLEY

FIG #: 14-83

MANAGER: G. STROMMEN

DRAFTER: A. MOSTAFA

DATE: 12/5/2022

SCALE: AS NOTED

PAGE #: 3 OF 6

PARTS LIST		
ITEM	QTY	PART NUMBER
1.1	2	SIDE PLATE



DIGITAL DESIGN
GRAPHICS
TECHNOLOGY

WWW.DDGT.NET

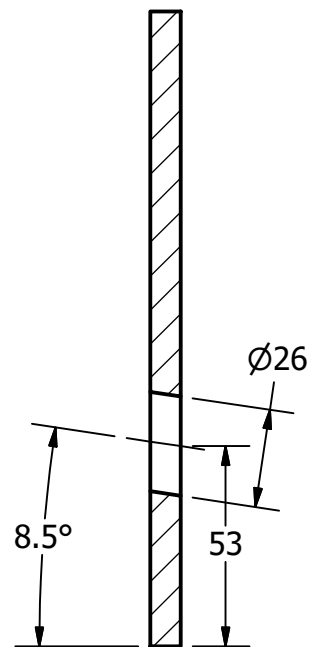
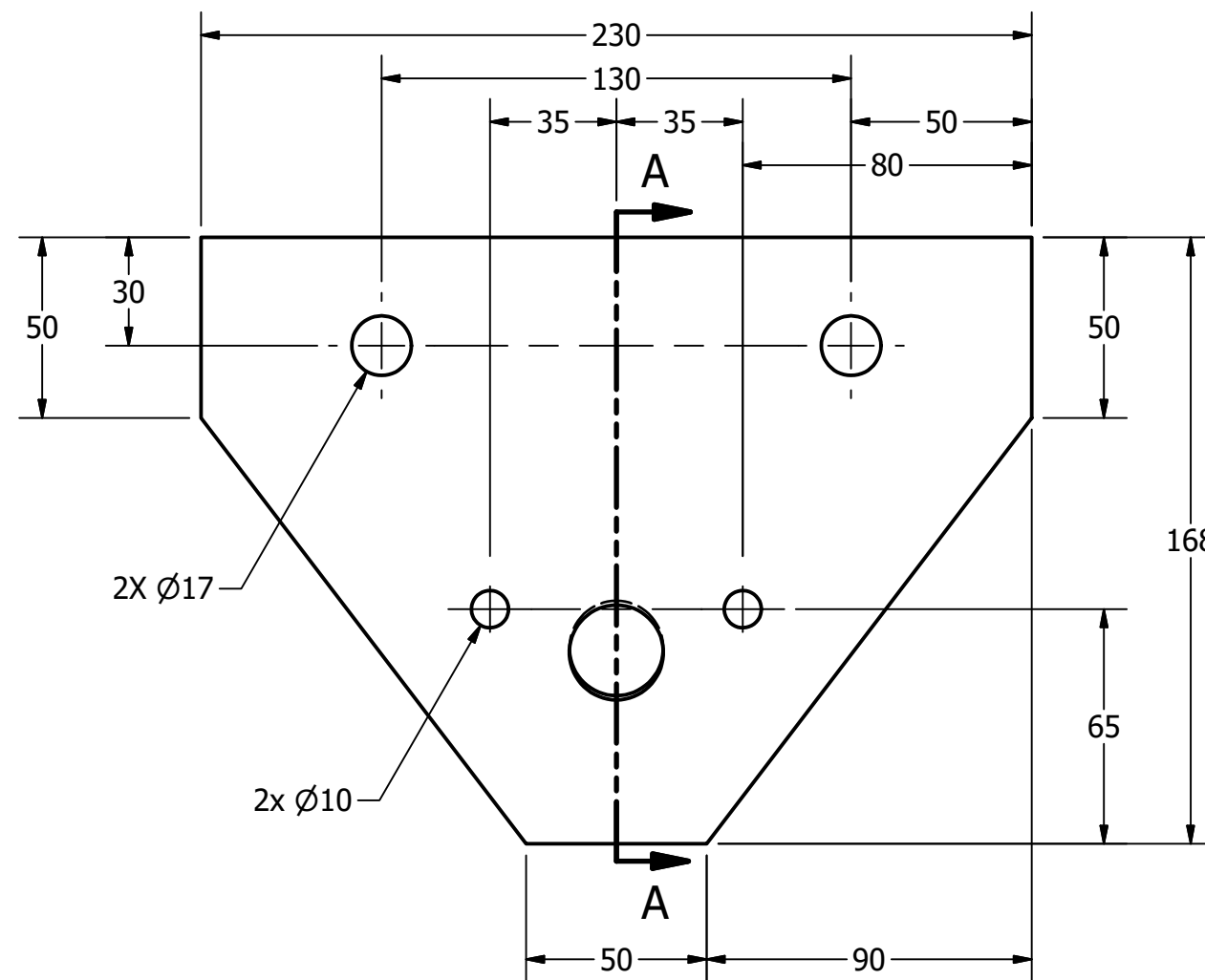
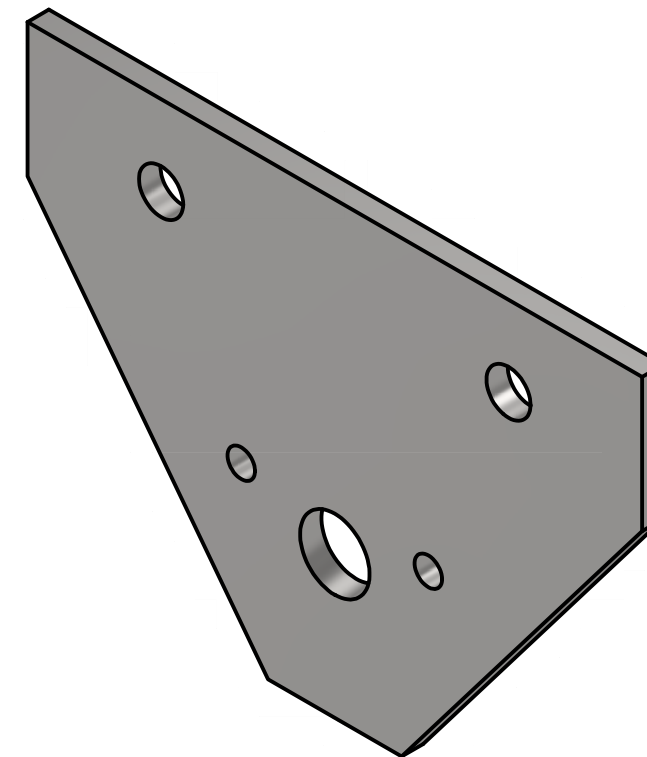

SECTION A-A
SCALE 1 / 2

SIDE PLATE
SCALE 1 / 2

METRIC

LEGEND:

- Ø DIAMETER
- R RADIUS
- ° DEGREES

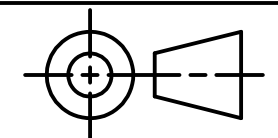

TOLERANCES UNLESS SPECIFIED:
MILLIMETERS:
WHOLE NUMBERS = ±.5
X = ±.010
XX = ±.005
FRACTIONAL ±1/64"
ANGLES ±1 DEGREE
SURFACES 32

CLASS: DDGT 120

ASSIGNMENT #: 70

INVENTOR DRAWING NAME:
TROLLEY

FIG #: 14-83

MANAGER: G. STROMMEN

DRAFTER: A. MOSTAFA

DATE: 12/5/2022

SCALE: AS NOTED

PAGE #: 4 OF 6

GENERAL NOTES:

TROLLEY TO BE MOUNTED ON AN
S200 X 34 BEAM

ALL CHAMFER ARE 2 X 2 UNLESS OTHERWISE NOTED

PARTS LIST		
ITEM	QTY	PART NUMBER
1.2	2	GUIDE
2	1	AXLE



DIGITAL DESIGN
GRAPHICS
TECHNOLOGY

WWW.DDGT.NET

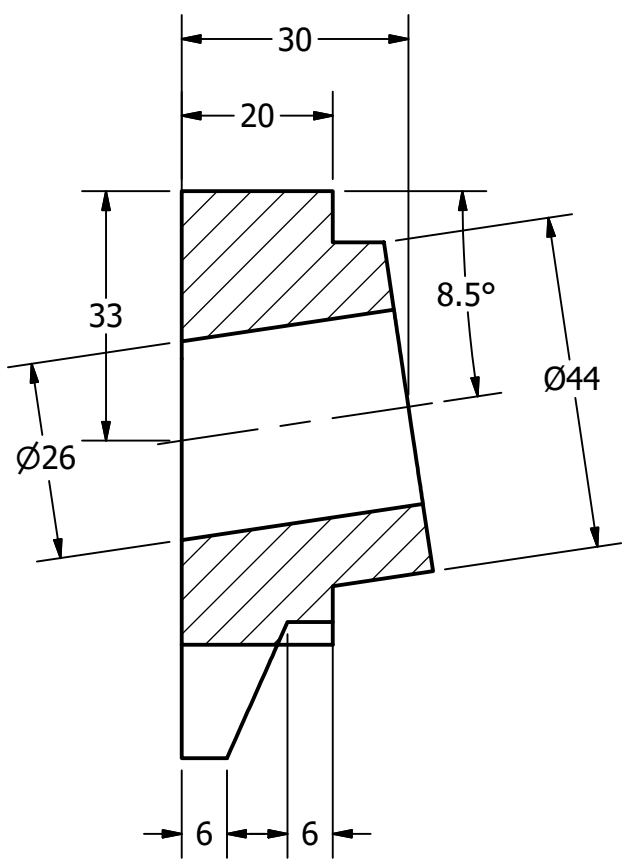

SECTION B-B
SCALE 1 : 1

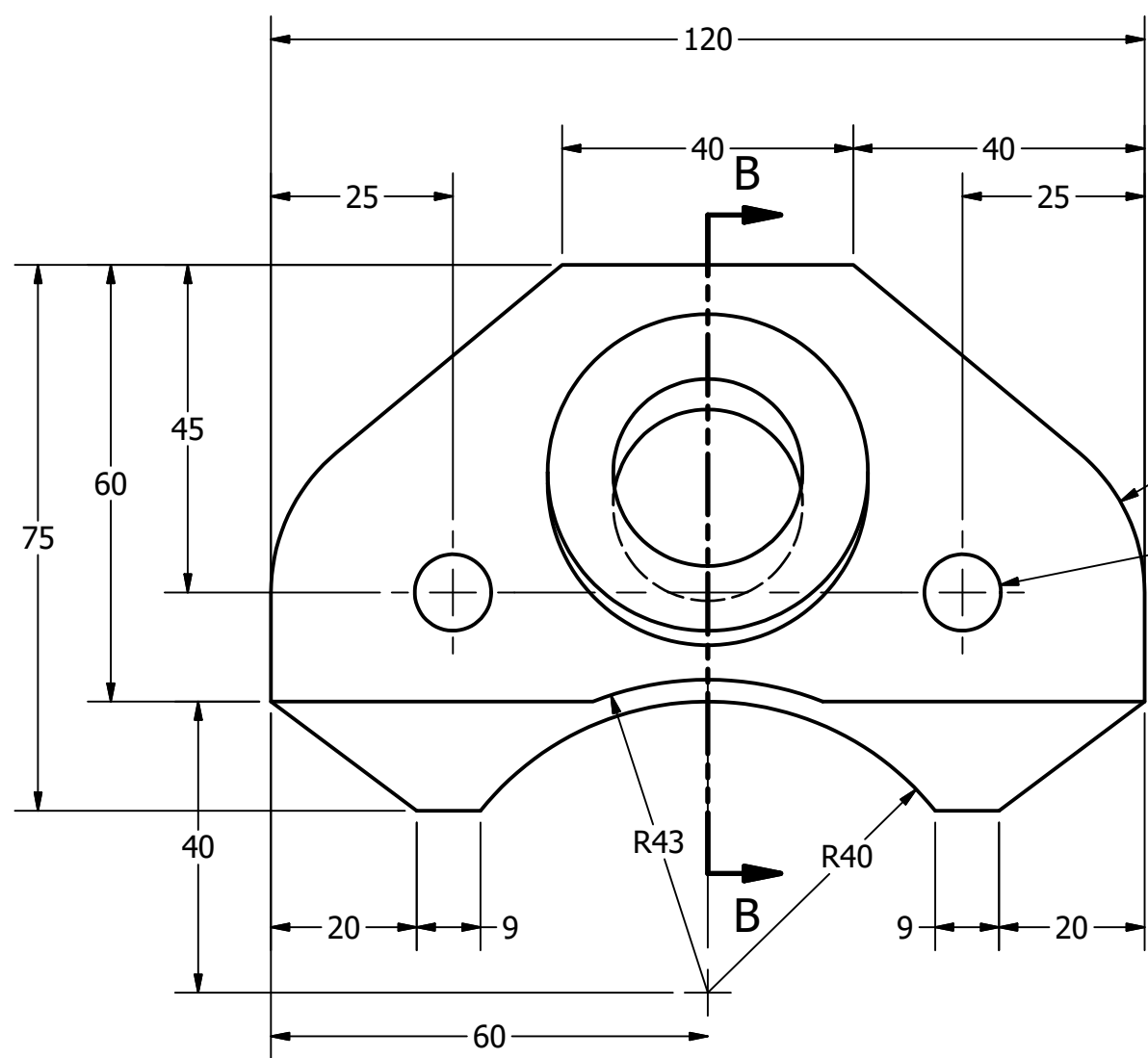

GUIDE
SCALE 1 : 1

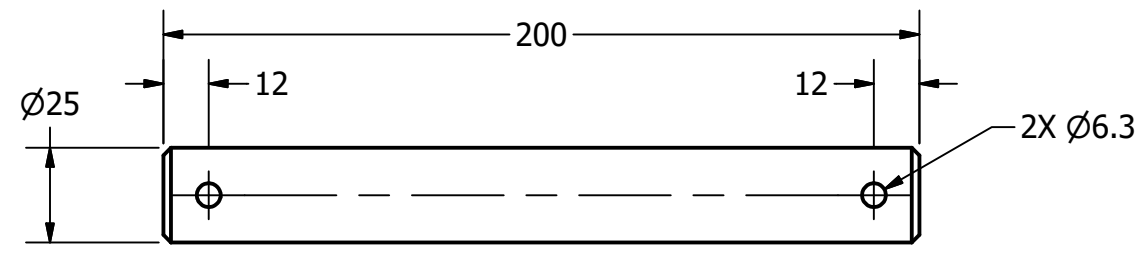
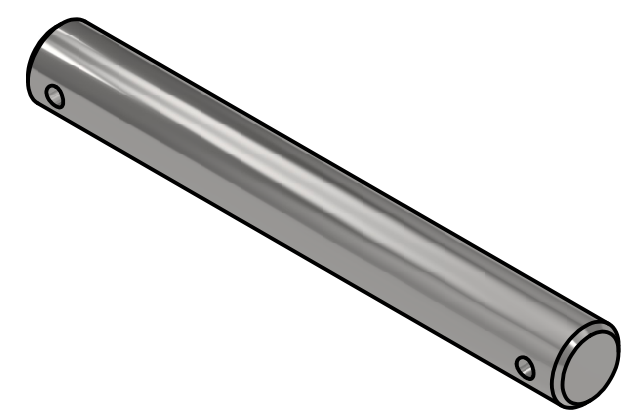
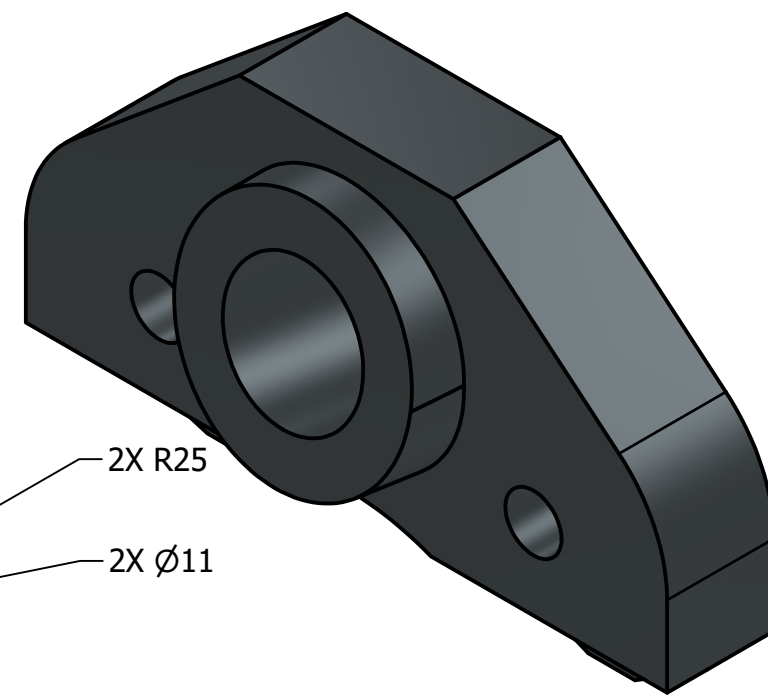

AXLE
SCALE 1 / 2

GENERAL NOTES:

TROLLEY TO BE MOUNTED ON AN S200 X 34 BEAM

ALL CHAMFER ARE 2 X 2 UNLESS OTHERWISE NOTED

LEGEND:

- Ø DIAMETER
- R RADIUS
- DEGREES

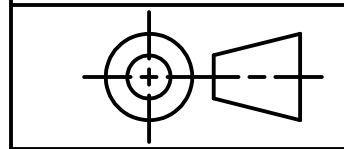

TOLERANCES UNLESS SPECIFIED:
MILLIMETERS:
WHOLE NUMBERS = ±.5
X = ±.010
XX = ±.005
FRACTIONAL ±1/64"
ANGLES ±1 DEGREE
SURFACES 32

CLASS: DDGT 120

ASSIGNMENT #: 70

INVENTOR DRAWING NAME:

TROLLEY

FIG #: 14-83

MANAGER: G. STROMMEN

DRAFTER: A. MOSTAFA

DATE: 12/5/2022

SCALE: AS NOTED

PAGE #: 5 OF 6

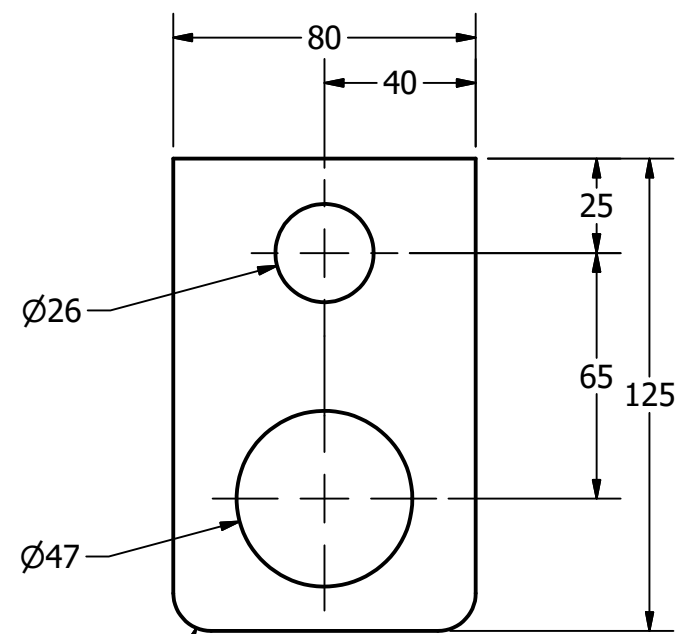

HOOK
SCALE 1 / 2

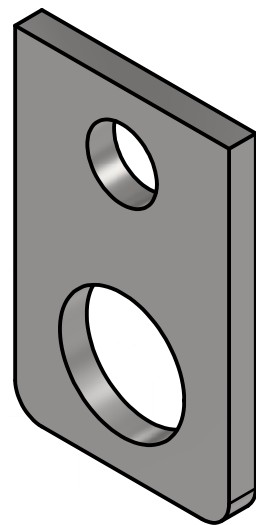

METRIC

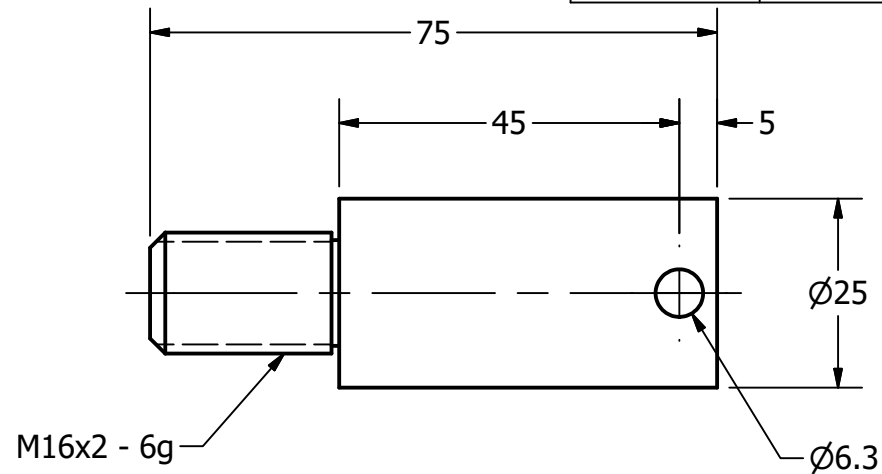

WHEEL AXLE
SCALE 1 : 1

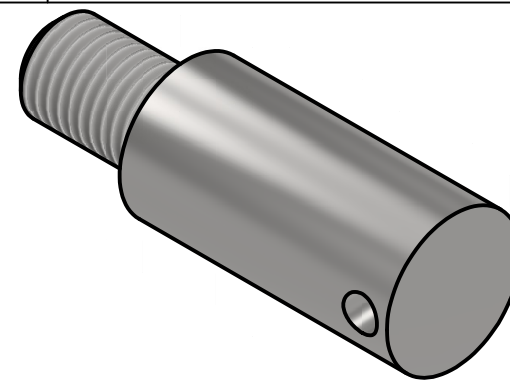

PARTS LIST		
ITEM	QTY	PART NUMBER
3	1	HOOK
5	4	WHEEL
6	4	WHEEL AXLE



DIGITAL DESIGN
GRAPHICS
TECHNOLOGY

WWW.DDGT.NET

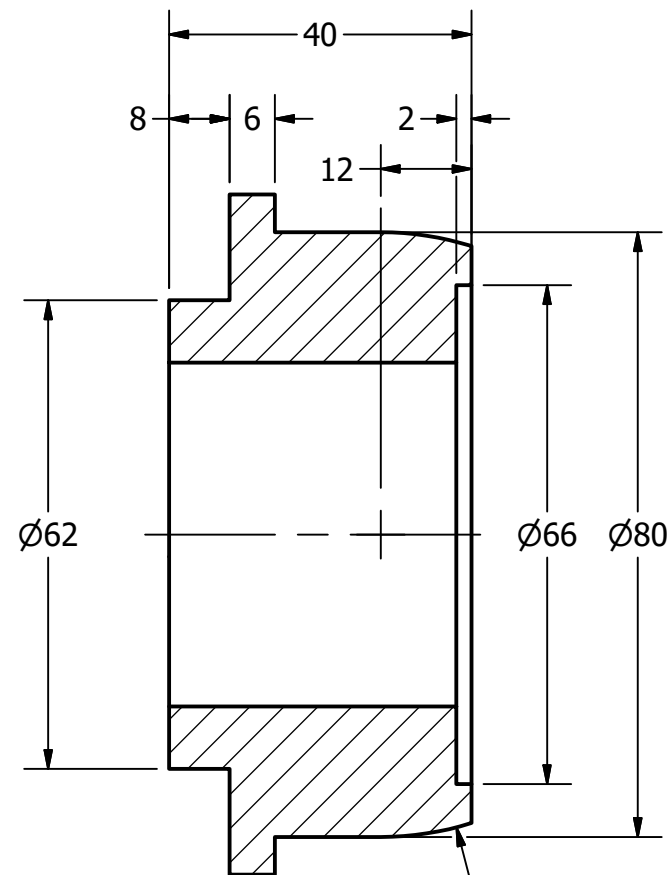

SECTION C-C
SCALE 1 : 1

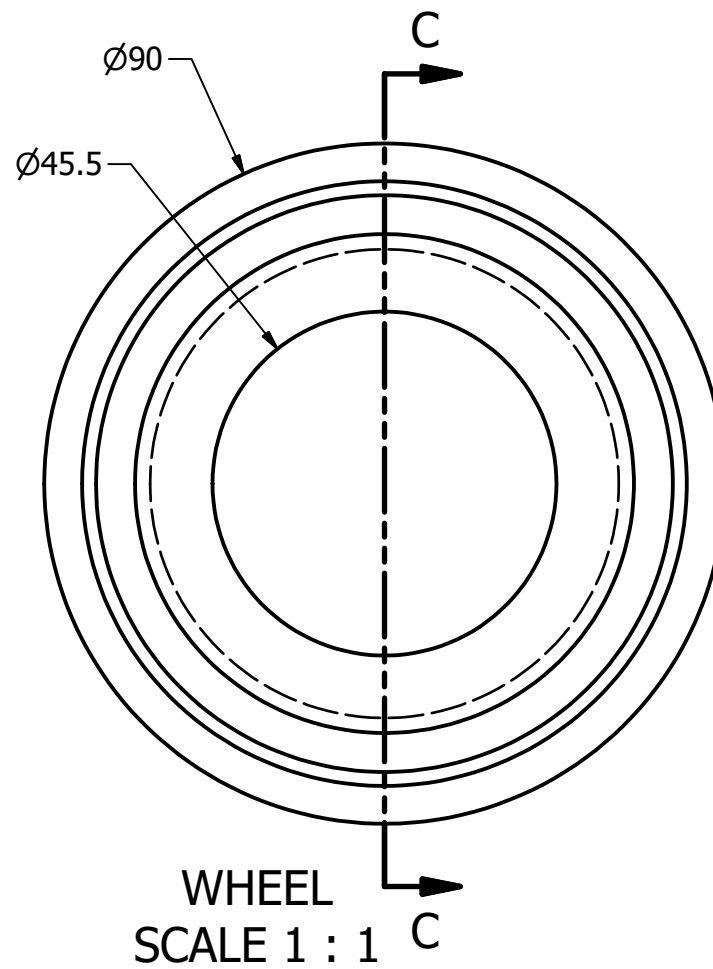

WHEEL
SCALE 1 : 1

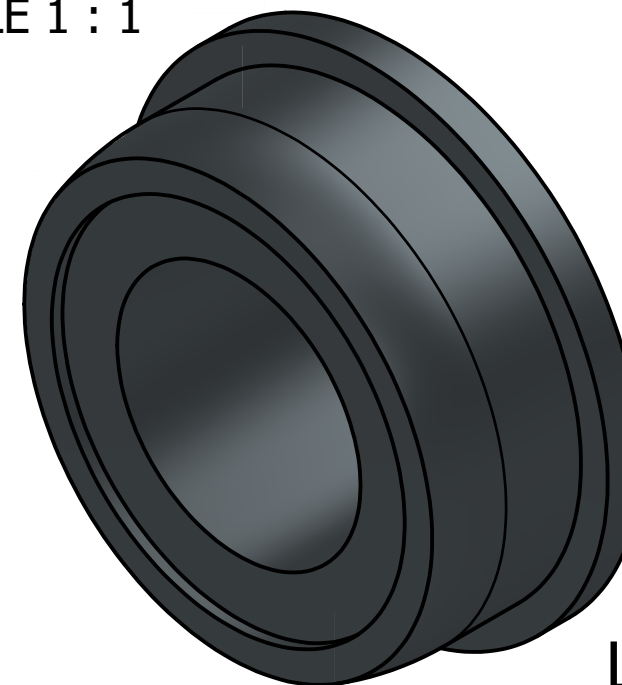

LEGEND:

- Ø DIAMETER
- R RADIUS
- ° DEGREES

GENERAL NOTES:

TROLLEY TO BE MOUNTED ON AN
S200 X 34 BEAM

ALL CHAMFER ARE 2 X 2 UNLESS OTHERWISE NOTED

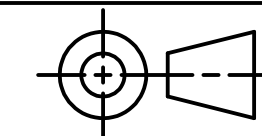

TOLERANCES UNLESS SPECIFIED:
MILLIMETERS:
WHOLE NUMBERS = ±.5
X = ±.010
XX = ±.005
FRACTIONAL ±1/64"
ANGLES ±1 DEGREE
SURFACES 32

CLASS: DDGT 120

ASSIGNMENT #: 70

INVENTOR DRAWING NAME:
TROLLEY

FIG #: 14-83

MANAGER: G. STROMMEN

DRAFTER: A. MOSTAFA

DATE: 12/5/2022

SCALE: AS NOTED

PAGE #: 6 OF 6