

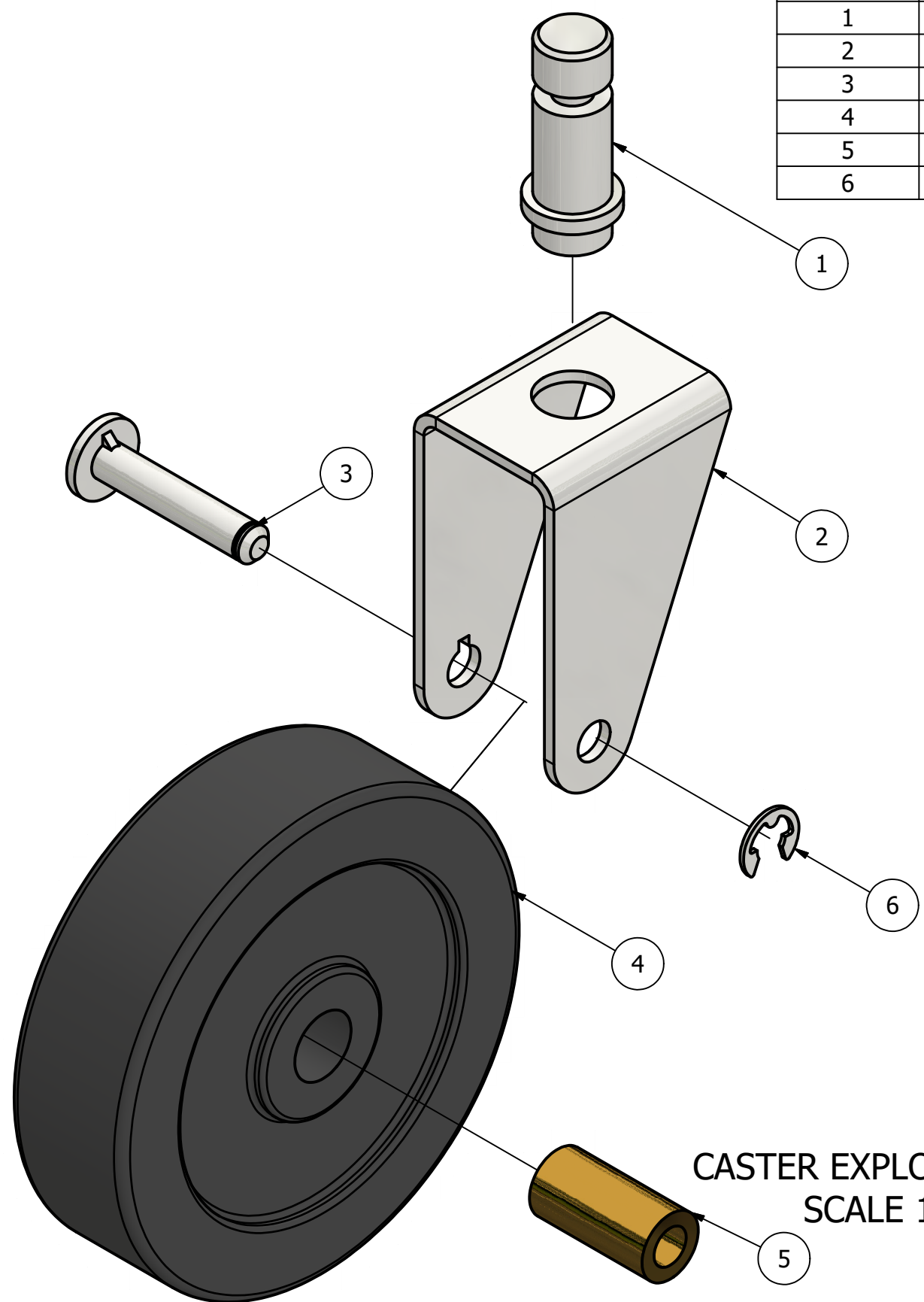

DIGITAL DESIGN
GRAPHICS
TECHNOLOGY

WWW.DDGT.NET

PARTS LIST				
ITEM	QTY	PART NUMBER	MATERIAL	DESCRIPTION
1	1	POST	SAE 1112	
2	1	BRACKET	USS STEEL	13 GA (2.38)
3	1	SHAFT	SAE 1112	
4	1	WHEEL	HARD RUBBER	
5	1	BUSHING	BRASS	
6	1	RETAINING RING	STEEL	EXT SERIES 5133



CASTER EXPLODED VIEW
SCALE 1 : 1

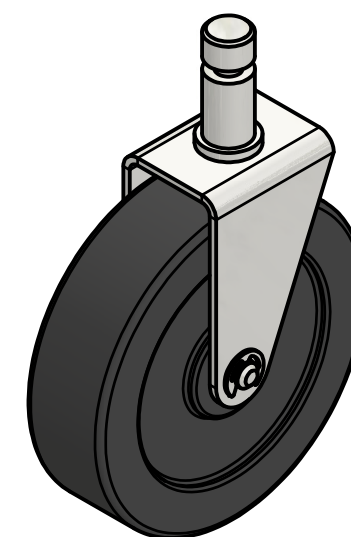

CASTER ASSEMBLED
SCALE 1 / 2

METRIC

LEGEND:

- Ø DIAMETER
- R RADIUS
- ° DEGREES

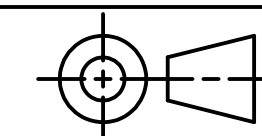

TOLERANCES UNLESS SPECIFIED:
 DECIMAL INCHES:
 X = ±.020
 XX = ±.010
 XXX = ±.005
 FRACTIONAL ±1/64"
 ANGLES ±1 DEGREE
 SURFACES $\sqrt{\text{32}}$

CLASS: DDGT 120

ASSIGNMENT #: 68

INVENTOR DRAWING NAME:
14-90 CASTER

FIG #: 14-90

MANAGER: G. STROMMEN

DRAFTER: A. MOSTAFA

DATE: 11/15/2022

SCALE: AS NOTED

PAGE #: 1 OF 3

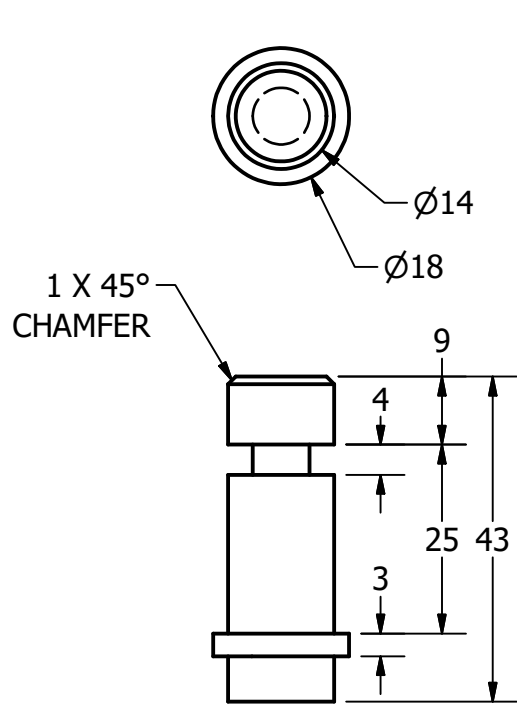

POST
SCALE 1 : 1

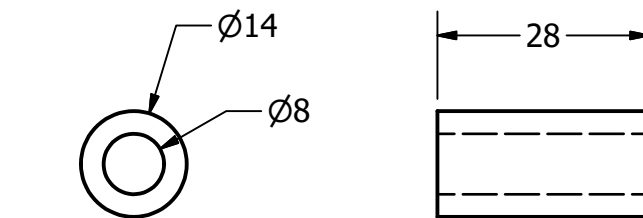
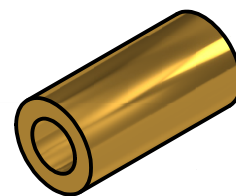
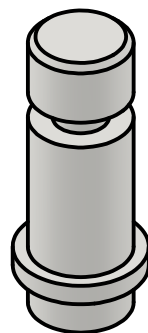

BUSHING
SCALE 1 : 1

PARTS LIST		
ITEM	QTY	PART NUMBER
1	1	POST
3	1	SHAFT
4	1	WHEEL
5	1	BUSHING
6	1	RETAINING RING



DIGITAL DESIGN
GRAPHICS
TECHNOLOGY

WWW.DDGT.NET

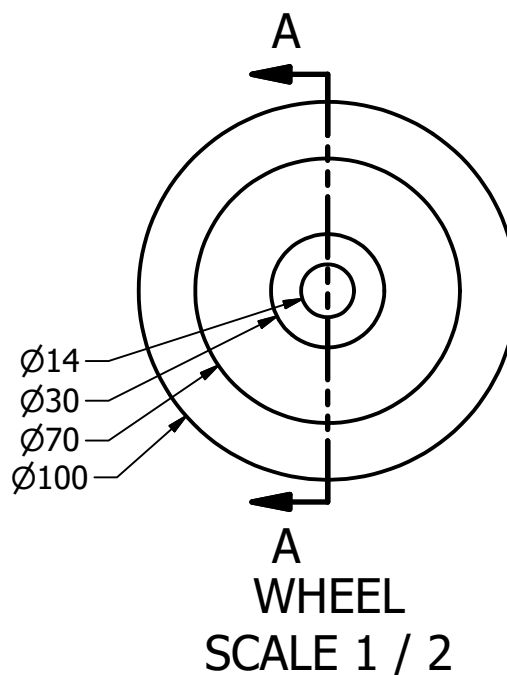
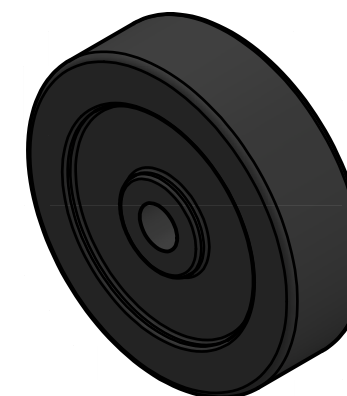

WHEEL
SCALE 1 / 2

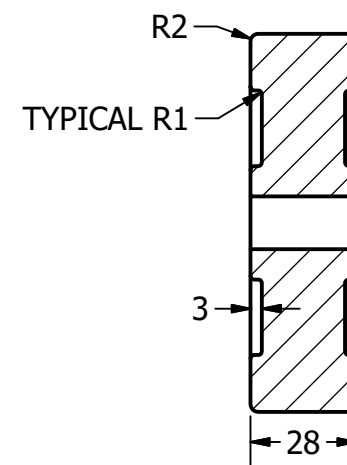

SECTION A-A
SCALE 1 / 2

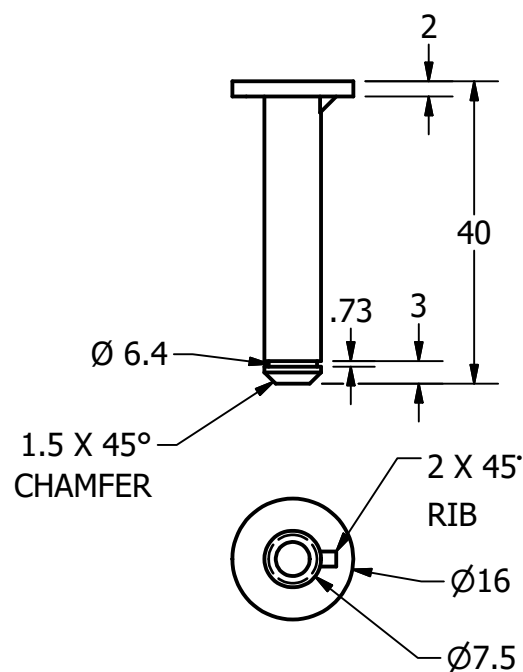

SHAFT
SCALE 1 : 1

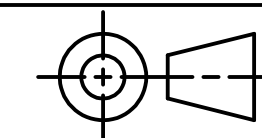
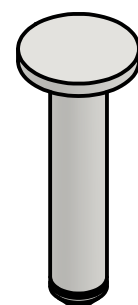

TOLERANCES UNLESS SPECIFIED:
DECIMAL INCHES:
X = ±.020
XX = ±.010
XXX = ±.005
FRACTIONAL ±1/64"
ANGLES ±1 DEGREE
SURFACES $\sqrt{\quad}$

CLASS: DDGT 120

ASSIGNMENT #: 68

INVENTOR DRAWING NAME:
14-90 CASTER

FIG #: 14-90

MANAGER: G. STROMMEN

DRAFTER: A. MOSTAFA

DATE: 11/15/2022

SCALE: AS NOTED

PAGE #: 2 OF 3

METRIC

LEGEND:

- Ø DIAMETER
- R RADIUS
- ° DEGREES

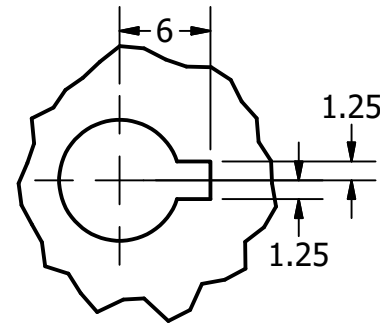
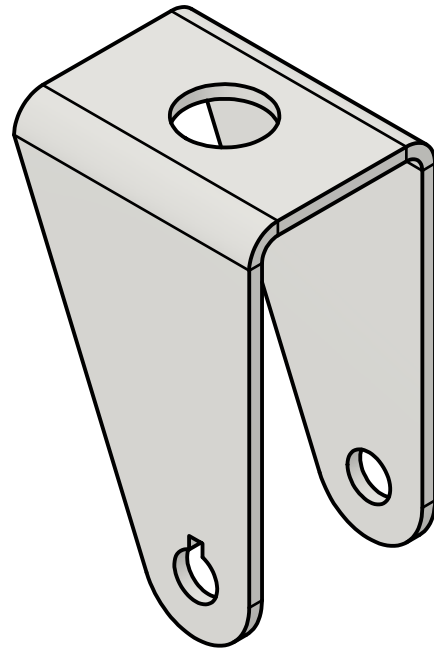
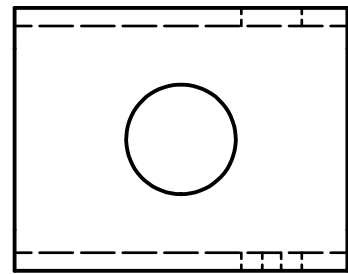

DETAIL A
SCALE 2 : 1

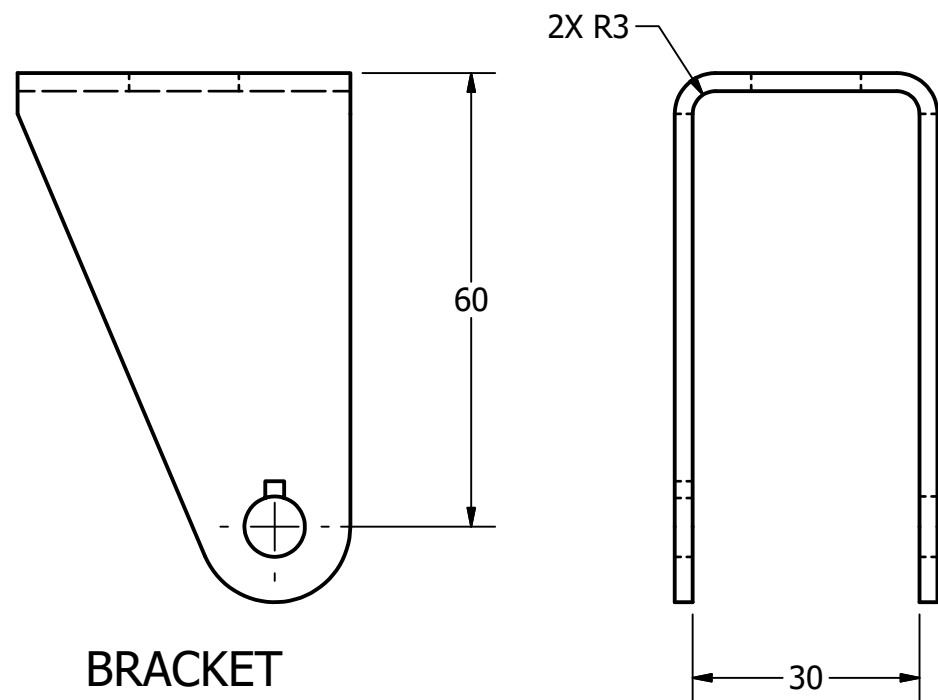

BRACKET
SCALE 1 : 1

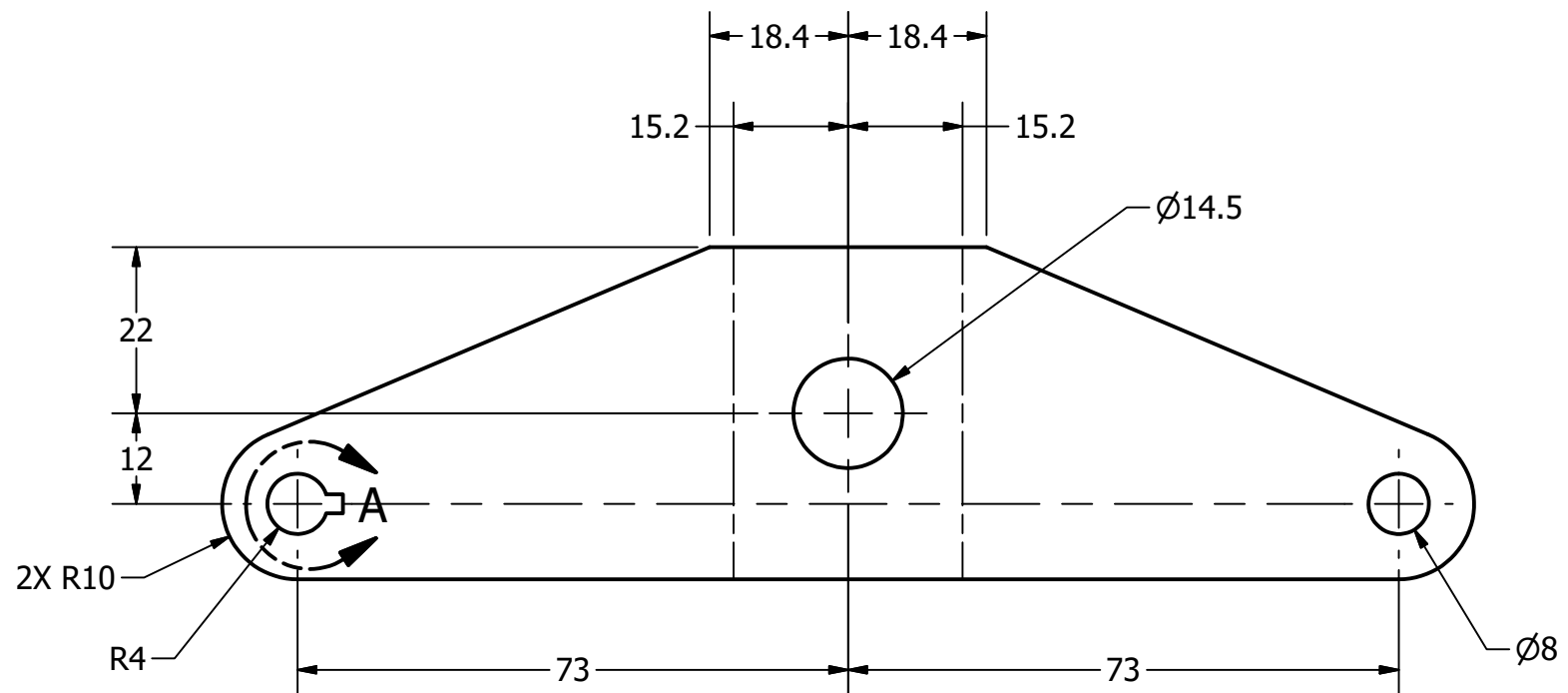

BRACKET FLAT PATTERN
SCALE 1 : 1

METRIC

LEGEND:

- Ø DIAMETER
- R RADIUS
- ° DEGREES

PARTS LIST		
ITEM	QTY	PART NUMBER
2	1	BRACKET



DIGITAL DESIGN
GRAPHICS
TECHNOLOGY

WWW.DDGT.NET

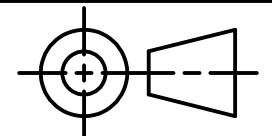

TOLERANCES UNLESS SPECIFIED:
DECIMAL INCHES:
X = ±.020
XX = ±.010
XXX = ±.005
FRACTIONAL ±1/64"
ANGLES ±1 DEGREE
SURFACES 32

CLASS: DDGT 120

ASSIGNMENT #: 68

INVENTOR DRAWING NAME:
14-90 CASTER

FIG #: 14-90

MANAGER: G. STROMMEN

DRAFTER: A. MOSTAFA

DATE: 11/15/2022

SCALE: AS NOTED

PAGE #: 3 OF 3