

TROLLEY ASSEMBLY
SCALE 1 / 2

PARTS LIST				
ITEM	QTY	PART NUMBER	MATERIAL	DESCRIPTION
1	2	SIDE PLATE SUB ASSEMBLY		SUB ASSEMBLY
1.1	2	SIDE PLATE	MILD STEEL	
1.2	2	GUIDE	CAST IRON	
1.3	4	RIVET	STANDARD	BUTTON HEAD, Ø10 X 60 LG
2	4	WHEEL	CAST IRON	
3	4	WHEEL AXLE	COLD ROLLED STEEL	
4	1	HOOK	MILD STEEL	
5	1	AXLE	COLD ROLLED STEEL	
6	44	ROLLER BEARING	COLD ROLLED STEEL	
7	6	COTTER PIN	STANDARD	Ø6 X 40 LG
8	4	LOCKNUT	STANDARD	M16 X 2 / PREVAILING TORQUE INSERT-TYPE
9	8	ADJUSTING WASHER	STANDARD	26 ID X 44 OD X 4 THK
10	4	WASHER	STANDARD	26 ID X 65 OD X 3 THK

GENERAL NOTES:
TROLLEY ASSEMBLY TO BE MOUNTED
TO S200 X 34 BEAM

METRIC

LEGEND:
Ø DIAMETER
R RADIUS
° DEGREES



DIGITAL DESIGN
GRAPHICS
TECHNOLOGY

WWW.DDGT.NET

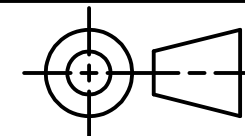

TOLERANCES UNLESS SPECIFIED:
MILLIMETERS:
WHOLE NUMBERS = ± .5
X = ± .25
XX = ± .12

ANGLES ± 1 DEGREE

SURFACES $\sqrt{32}$

COURSE: DDGT120

INVENTOR DRAWING NAME:
TROLLEY

FIG #: 14-83

DRAFTER: B.LOPEZ

DATE: 12/4/2018

SCALE: AS NOTED

PAGE #: 1 OF 6

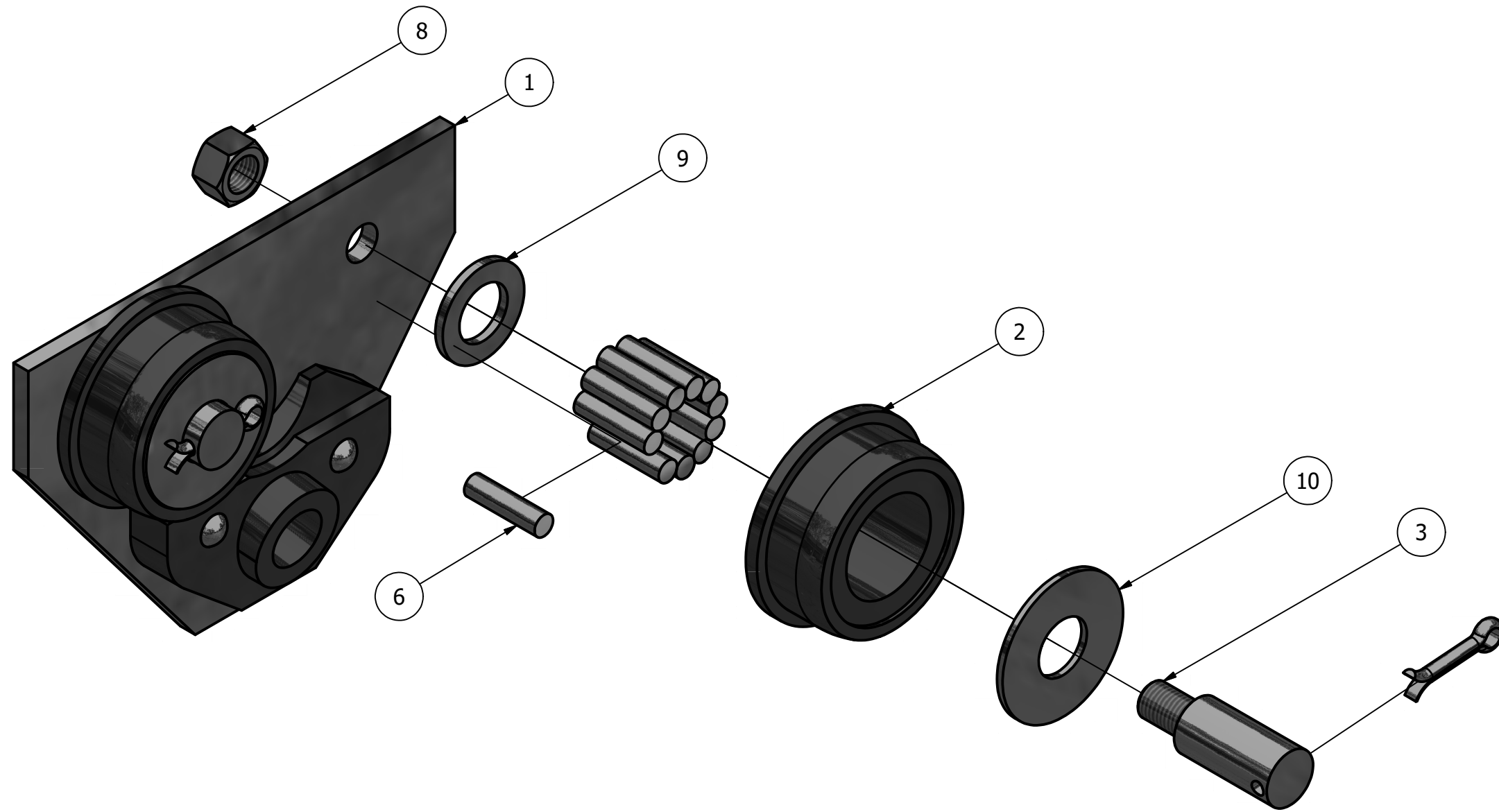

PARTS LIST		
ITEM	QTY	PART NUMBER
1	2	SIDE PLATE SUB ASSEMBLY
1.1	2	SIDE PLATE
1.2	2	GUIDE
1.3	4	RIVET
2	4	WHEEL
3	4	WHEEL AXLE
4	1	HOOK
5	1	AXLE
6	44	ROLLER BEARING
7	6	COTTER PIN
8	4	LOCKNUT
9	8	ADJUSTING WASHER
10	4	WASHER

SIDE PLATE EXPLODED ASSEMBLY
SCALE 1 / 2

SIDE PLATE EXPLODED SUB ASSEMBLY
SCALE 1 / 4

GENERAL NOTES:

TROLLEY ASSEMBLY TO BE MOUNTED TO S200 X 34 BEAM

LEGEND:

- ∅ DIAMETER
- R RADIUS
- ° DEGREES

METRIC



DIGITAL DESIGN
GRAPHICS
TECHNOLOGY

WWW.DDGT.NET

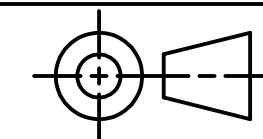

TOLERANCES UNLESS SPECIFIED:
MILLIMETERS:
WHOLE NUMBERS = ± .5
X = ± .25
XX = ± .12

ANGLES ± 1 DEGREE

SURFACES $\sqrt{32}$

COURSE: DDGT120

INVENTOR DRAWING NAME:
TROLLEY

FIG #: 14-83

DRAFTER: B.LOPEZ

DATE: 12/4/2018

SCALE: AS NOTED

PAGE #: 2 OF 6

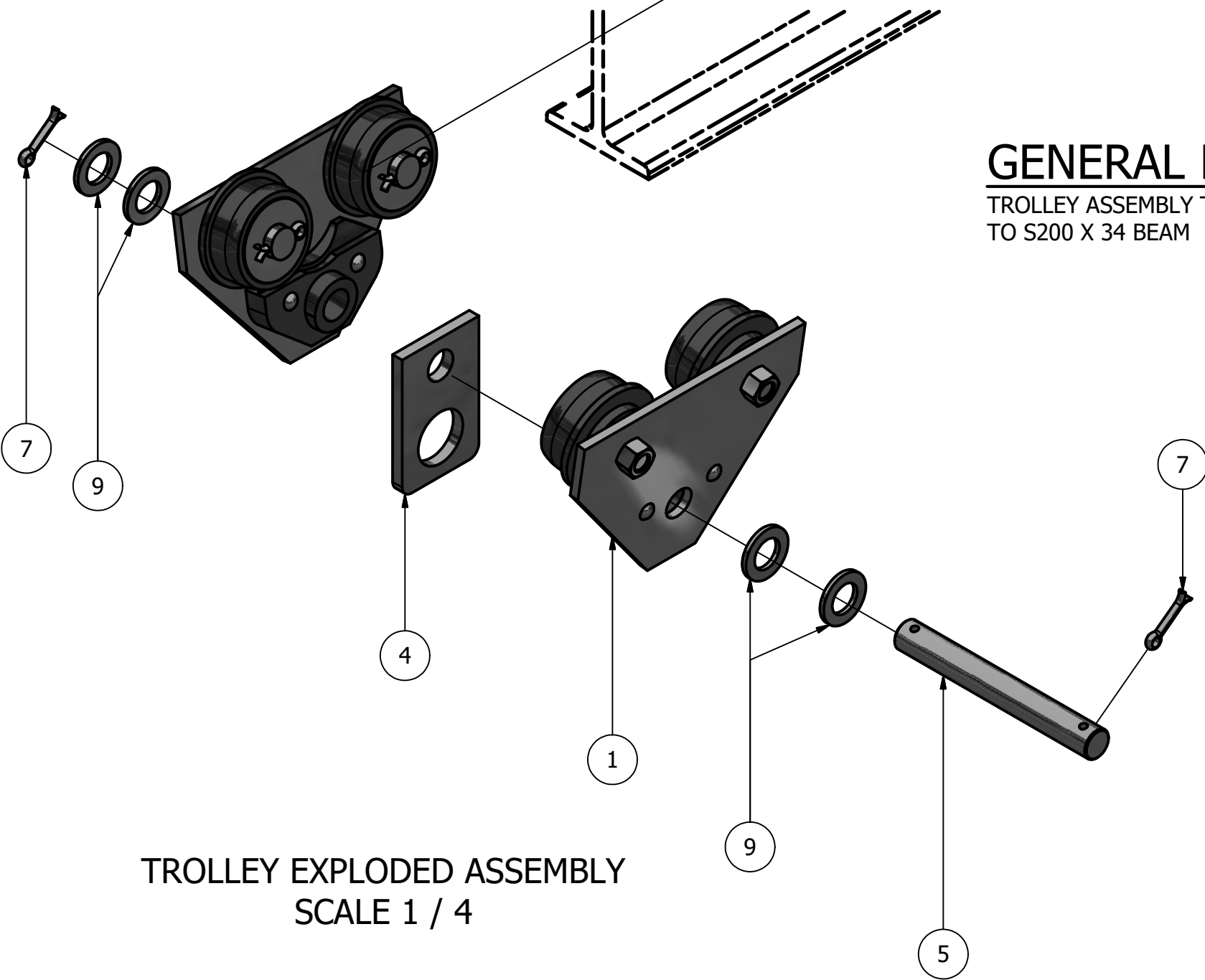

GENERAL NOTES:
 TROLLEY ASSEMBLY TO BE MOUNTED
 TO S200 X 34 BEAM

PARTS LIST		
ITEM	QTY	PART NUMBER
1	2	SIDE PLATE SUB ASSEMBLY
1.1	2	SIDE PLATE
1.2	2	GUIDE
1.3	4	RIVET
2	4	WHEEL
3	4	WHEEL AXLE
4	1	HOOK
5	1	AXLE
6	44	ROLLER BEARING
7	6	COTTER PIN
8	4	LOCKNUT
9	8	ADJUSTING WASHER
10	4	WASHER

TROLLEY EXPLODED ASSEMBLY
 SCALE 1 / 4

LEGEND:

- ∅ DIAMETER
- R RADIUS
- ° DEGREES

METRIC



DIGITAL DESIGN
 GRAPHICS
 TECHNOLOGY

WWW.DDGT.NET

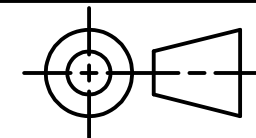

TOLERANCES UNLESS SPECIFIED:
 MILLIMETERS:
 WHOLE NUMBERS = ± .5
 X = ± .25
 XX = ± .12

ANGLES ± 1 DEGREE

SURFACES $\sqrt{32}$

COURSE: DDGT120

INVENTOR DRAWING NAME:
 TROLLEY

FIG #: 14-83

DRAFTER: B.LOPEZ

DATE: 12/4/2018

SCALE: AS NOTED

PAGE #: 3 OF 6

PARTS LIST		
ITEM	QTY	PART NUMBER
1.1	4	SIDE PLATE

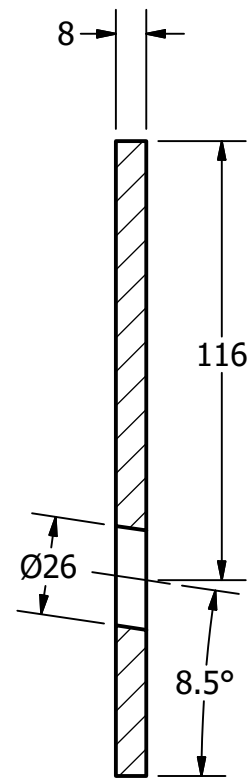

SECTION A-A
SCALE 1 / 2

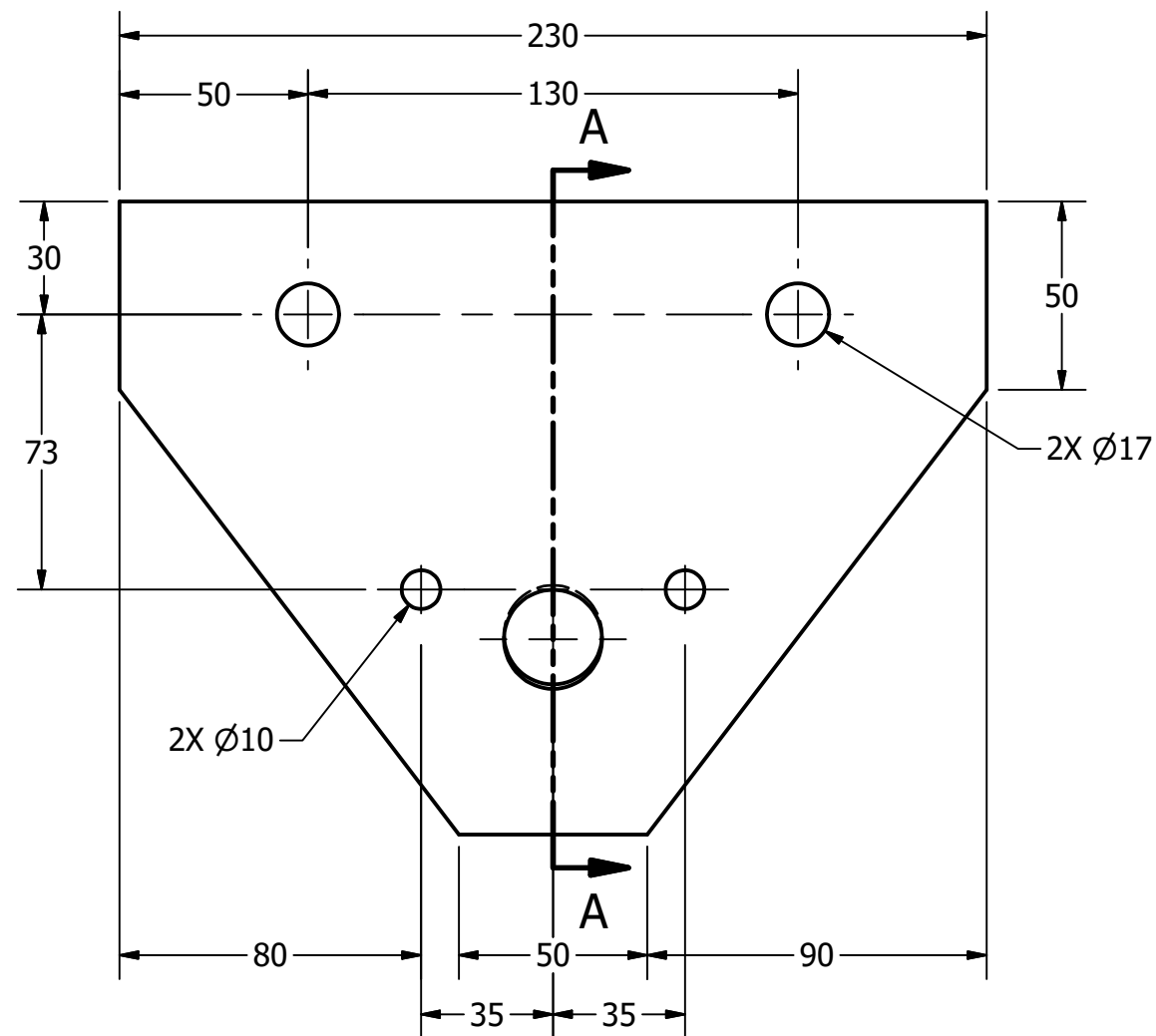

SIDE PLATE
SCALE 1 / 2

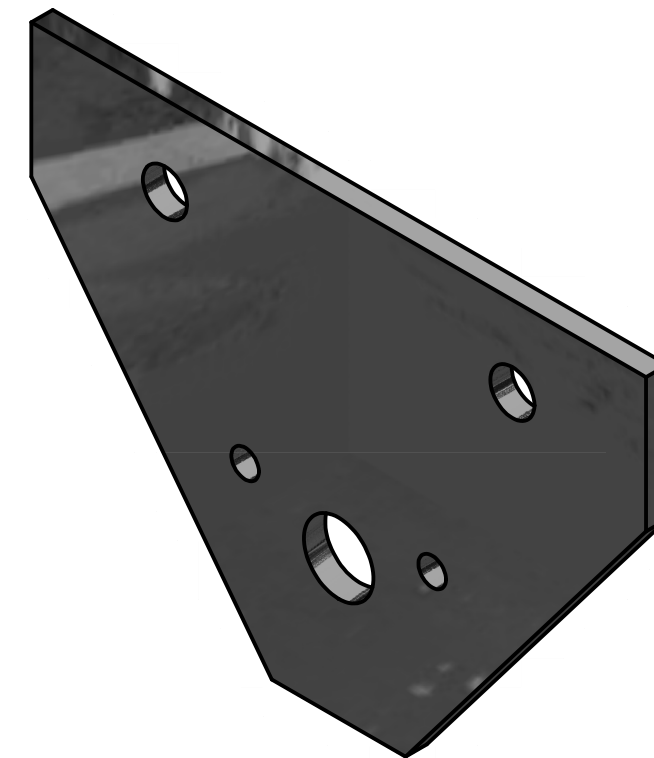

LEGEND:

- Ø DIAMETER
- R RADIUS
- ° DEGREES

METRIC



DIGITAL DESIGN
GRAPHICS
TECHNOLOGY

WWW.DDGT.NET

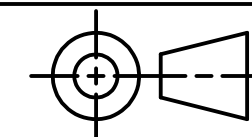

TOLERANCES UNLESS SPECIFIED:
MILLIMETERS:
WHOLE NUMBERS = ± .5
X = ± .25
XX = ± .12

ANGLES ± 1 DEGREE

SURFACES 32 ✓

COURSE: DDGT120

INVENTOR DRAWING NAME:
TROLLEY

FIG #: 14-83

DRAFTER: B.LOPEZ

DATE: 12/4/2018

SCALE: AS NOTED

PAGE #: 4 OF 6

PARTS LIST		
ITEM	QTY	PART NUMBER
4	1	HOOK
1.2	4	GUIDE
6	44	ROLLER BEARING

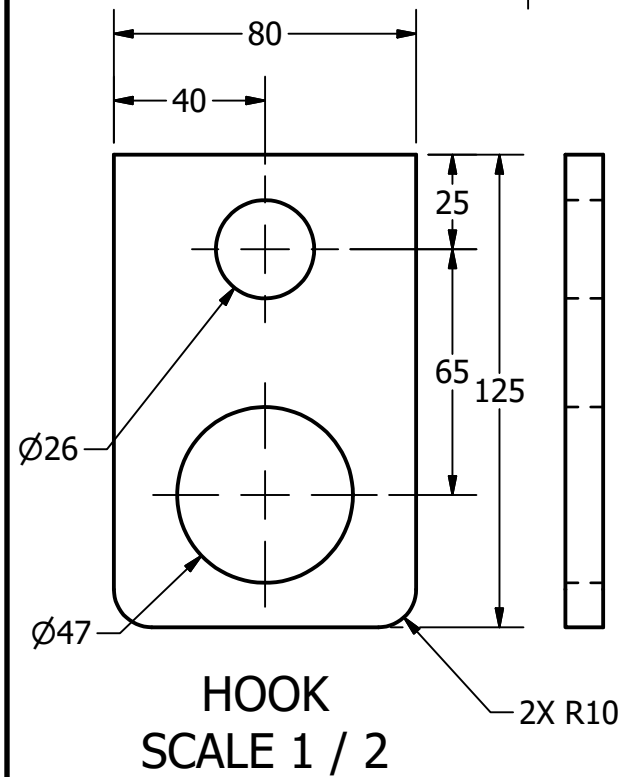
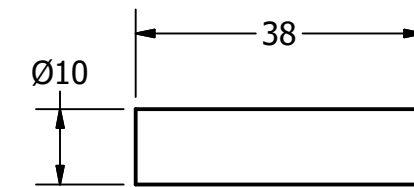
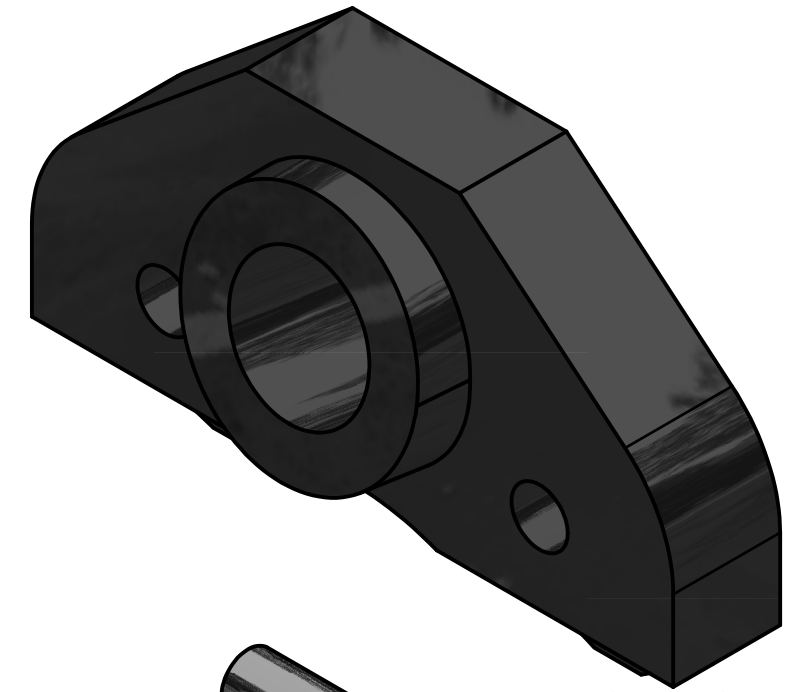
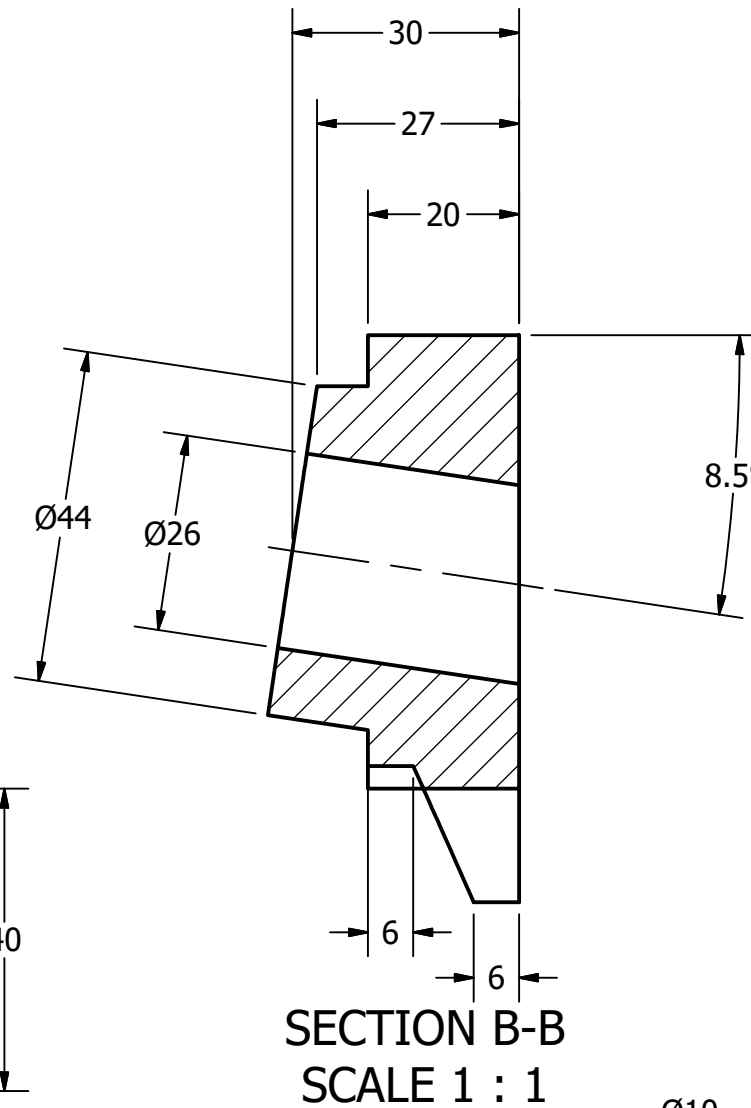
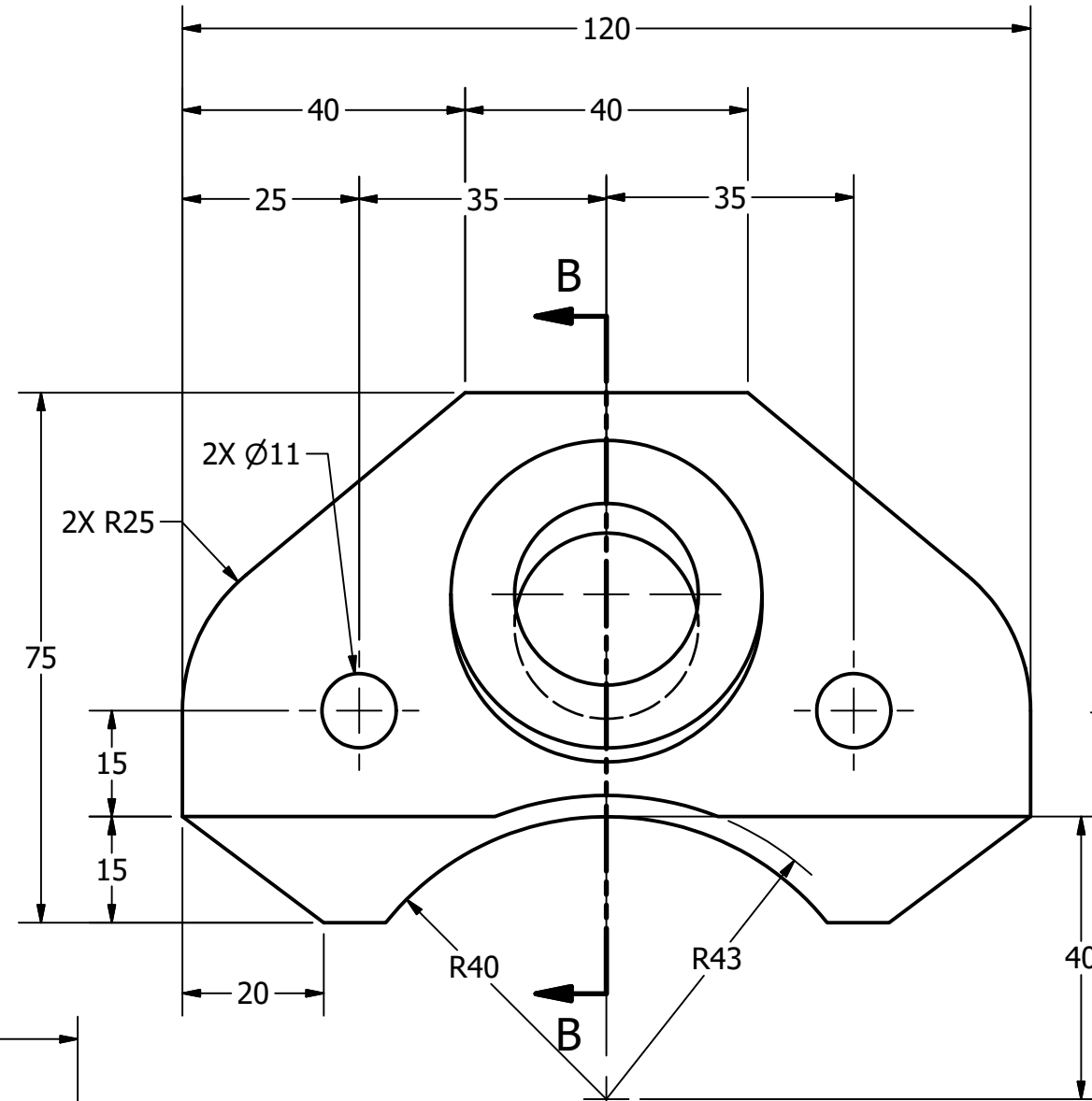

GUIDE
SCALE 1 : 1

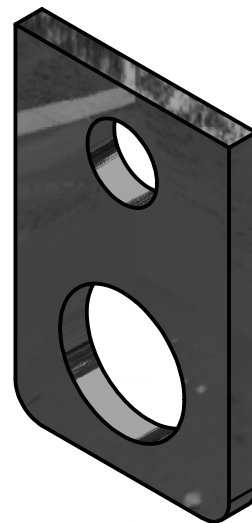

SECTION B-B
SCALE 1 : 1

ROLLER BEARING
SCALE 1 : 1



DIGITAL DESIGN
GRAPHICS
TECHNOLOGY

WWW.DDGT.NET

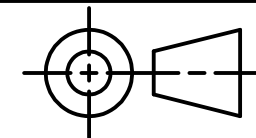

TOLERANCES UNLESS SPECIFIED:
MILLIMETERS:
WHOLE NUMBERS = ± .5
X = ± .25
XX = ± .12

ANGLES ± 1 DEGREE

SURFACES $\sqrt{32}$

COURSE: DDGT120

INVENTOR DRAWING NAME:
TROLLEY

FIG #: 14-83

DRAFTER: B.LOPEZ

DATE: 12/4/2018

SCALE: AS NOTED

PAGE #: 5 OF 6

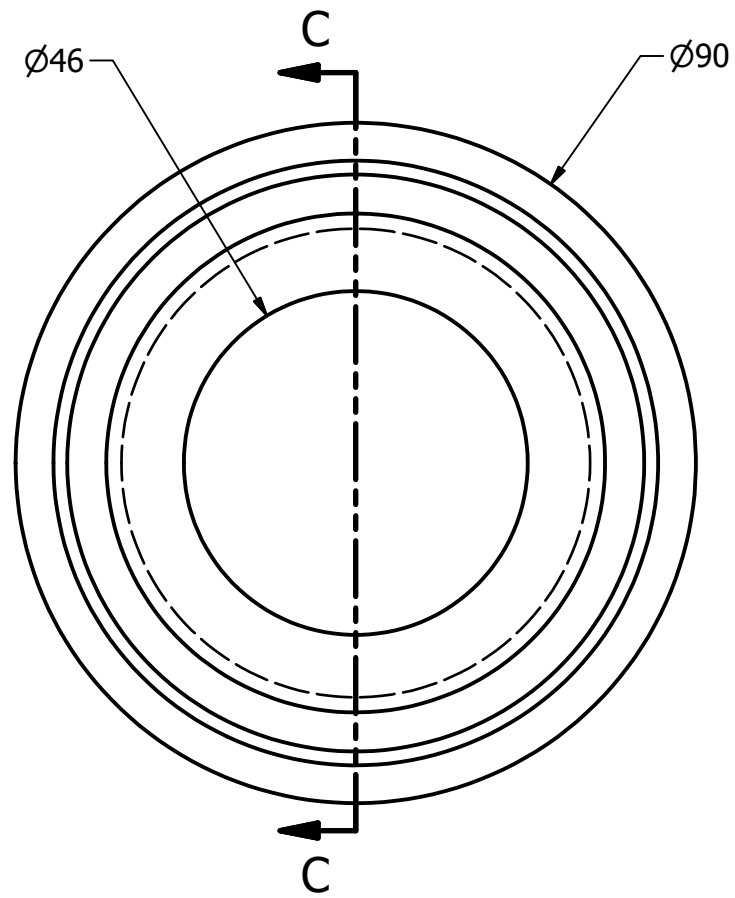

WHEEL
SCALE 1 : 1

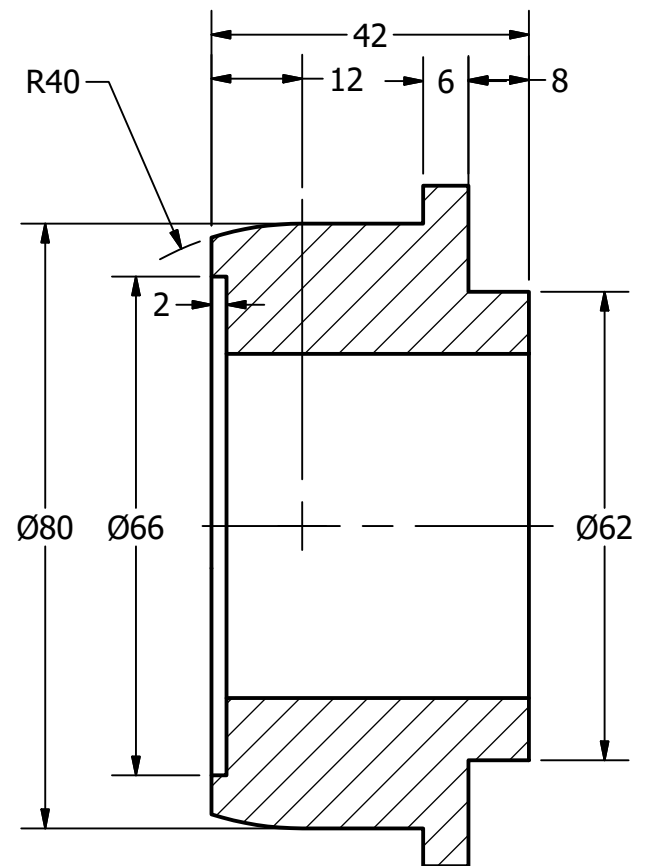

SECTION C-C
SCALE 1 : 1

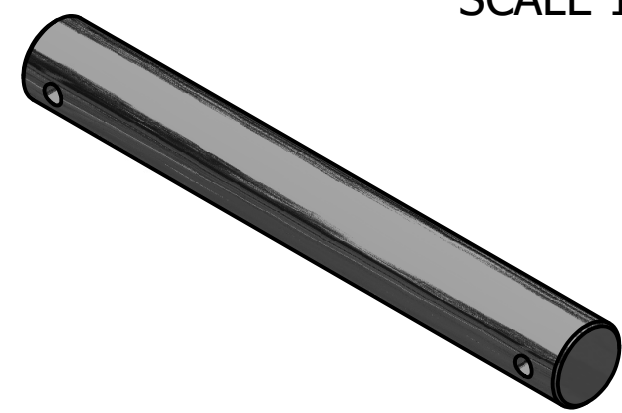
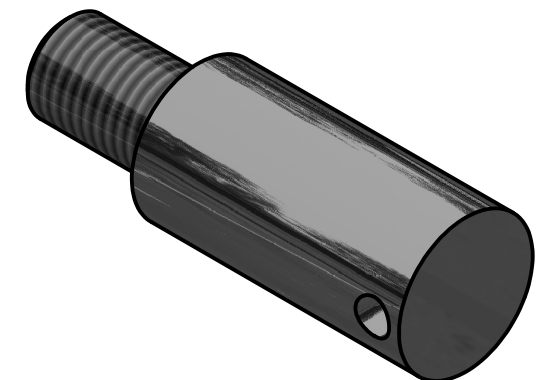

1 X 45.0° CHAMFER

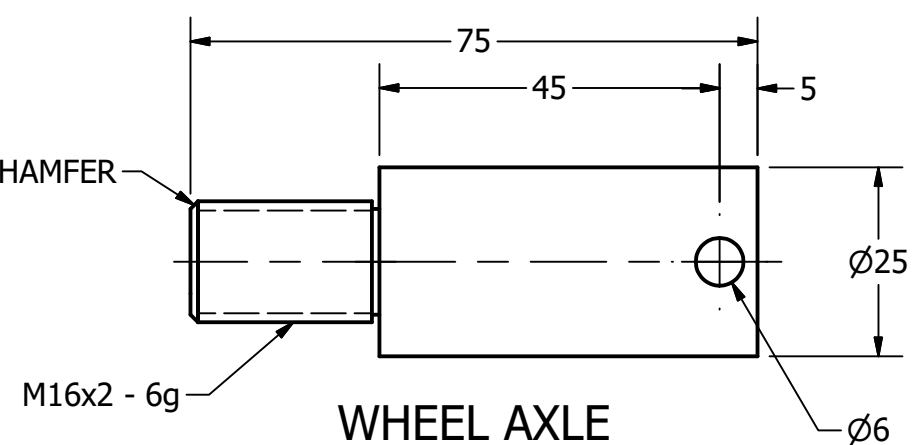

WHEEL AXLE
SCALE 1 : 1

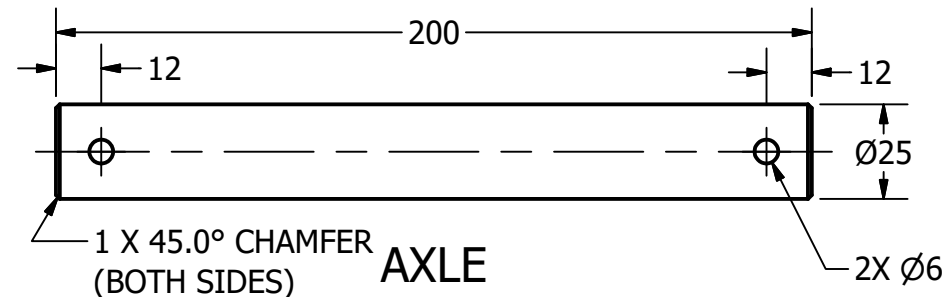

AXLE
SCALE 1 / 2

PARTS LIST		
ITEM	QTY	PART NUMBER
2	4	WHEEL
3	4	WHEEL AXLE
4	1	HOOK

DDGT

DIGITAL DESIGN
GRAPHICS
TECHNOLOGY

WWW.DDGT.NET

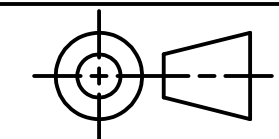

TOLERANCES UNLESS SPECIFIED:
MILLIMETERS:
WHOLE NUMBERS = ± .5
X = ± .25
XX = ± .12

ANGLES ± 1 DEGREE

SURFACES $\sqrt{32}$

COURSE: DDGT120

INVENTOR DRAWING NAME:

TROLLEY

FIG #: 14-83

DRAFTER: B.LOPEZ

DATE: 12/4/2018

SCALE: AS NOTED

PAGE #: 6 OF 6