

METRIC

TROLLEY
SCALE 1 / 2

PARTS LIST

ITEM	QTY	PART NUMBER	MATERIAL	DESCRIPTION
1	2	SIDE PLATE SUB ASSEMBLY		SUB-ASSEMBLY
1.1	2	SIDE PLATE	MILD STEEL	
1.2	2	GUIDE	CAST IRON	
1.3	4	RIVET	STANDARD	BUTTON HEAD, Ø10 X 60LG
2	1	HOOK	MILD STEEL	
3	4	WHEEL	CAST IRON	
4	1	AXLE	COLD ROLLED STEEL	
5	4	WHEEL AXLE	COLD ROLLED STEEL	
6	44	ROLLER BEARING	COLD ROLLED STEEL	
7	6	COTTER PIN	STANDARD	Ø6 X 40LG
8	4	LOCKNUT	STANDARD	M16 X 2 (PREVAILING TORQUE INSERT-TYPE)
9	8	ADJUSTING WASHER	STANDARD	Ø26ID X Ø44OD X 4THK
10	4	WASHER	STANDARD	Ø26ID X Ø65OD X 3THK

GENERAL NOTES:

TROLLEY ASSEMBLY TO BE MOUNTED TO S200 X 34 BEAM

LEGEND:

- Ø DIAMETER
- R RADIUS
- ° DEGREES
- LG LONG
- ID INSIDE DIAMETER
- OD OUTSIDE DIAMETER
- THK THICK



DIGITAL DESIGN
GRAPHICS
TECHNOLOGY

WWW.DDGT.NET

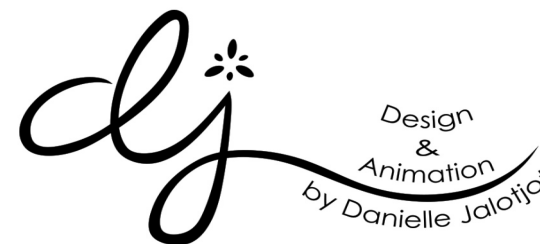

(707)208-7773 | dl.sipin@gmail.com | www.ddgt.net/StudentPages/djalotjot

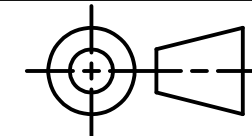

TOLERANCES UNLESS SPECIFIED:
MILLIMETERS:
WHOLE NUMBER = ±.5
X = ±.25
XX = ±.12

ANGLES ±1 DEGREE

SURFACES $\sqrt{32}$

COURSE: DDGT120

INVENTOR DRAWING NAME:
TROLLEY

FIG #: 14-83

DRAFTER: D. JALOTJOT

DATE: 12/6/2017

SCALE: AS NOTED

PAGE #: 1 OF 6

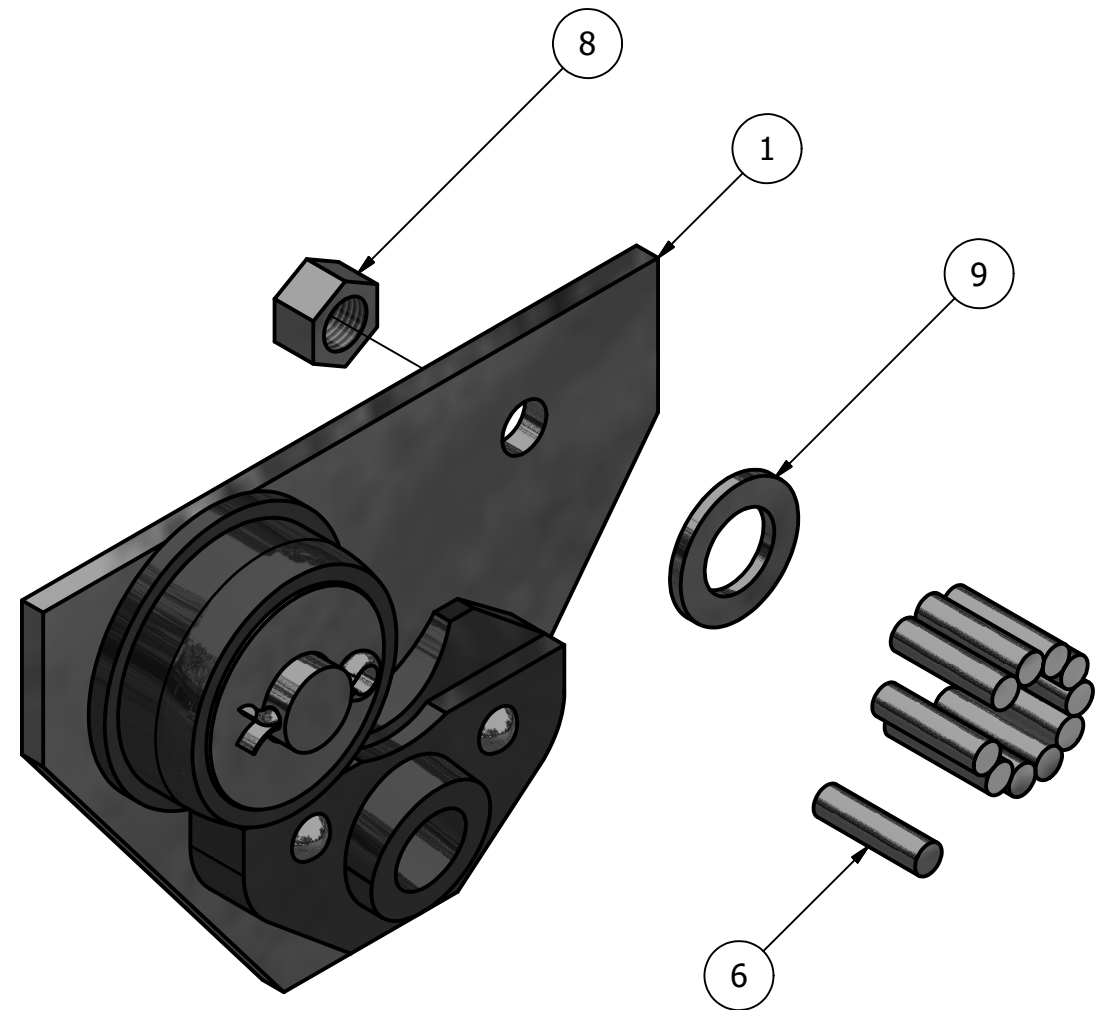

SIDE PLATE EXPLODED ASSEMBLY
SCALE 1 / 2

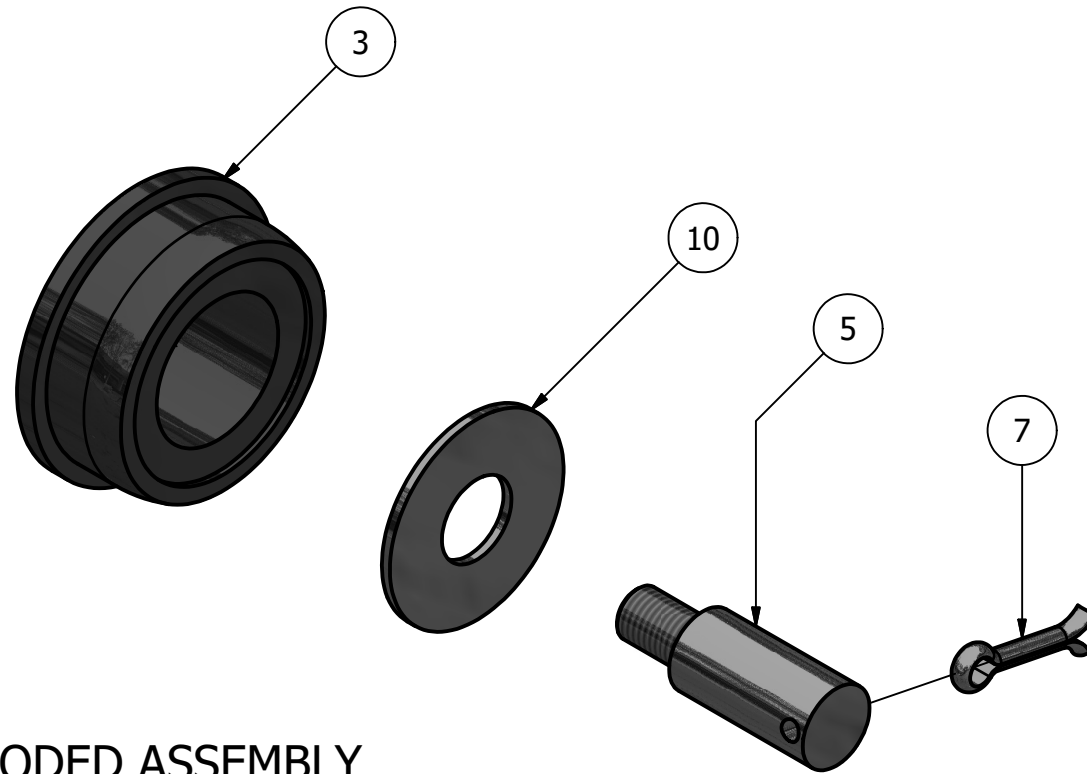

SIDE PLATE EXPLODED SUB-ASSEMBLY
SCALE 1 / 4

PARTS LIST		
ITEM	QTY	PART NUMBER
1	2	SIDE PLATE SUB ASSEMBLY
1.1	2	SIDE PLATE
1.2	2	GUIDE
1.3	4	RIVET
3	4	WHEEL
5	4	WHEEL AXLE
6	44	ROLLER BEARING
7	6	COTTER PIN
8	4	LOCKNUT
9	8	ADJUSTING WASHER
10	4	WASHER



DIGITAL DESIGN
GRAPHICS
TECHNOLOGY

WWW.DDGT.NET



(707)208-7773 | dl.sipin@gmail.com | www.ddgt.net/StudentPages/djalotjot

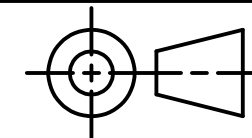

TOLERANCES UNLESS SPECIFIED:
MILLIMETERS:
WHOLE NUMBER = ±.5
X = ±.25
XX = ±.12

ANGLES ±1 DEGREE

SURFACES $\sqrt{32}$

COURSE: DDGT120

INVENTOR DRAWING NAME:
TROLLEY

FIG #: 14-83

DRAFTER: D. JALOTJOT

DATE: 12/6/2017

SCALE: AS NOTED

PAGE #: 2 OF 6

PARTS LIST		
ITEM	QTY	PART NUMBER
1	2	SIDE PLATE SUB ASSEMBLY
2	1	HOOK
4	1	AXLE
7	6	COTTER PIN
9	8	ADJUSTING WASHER

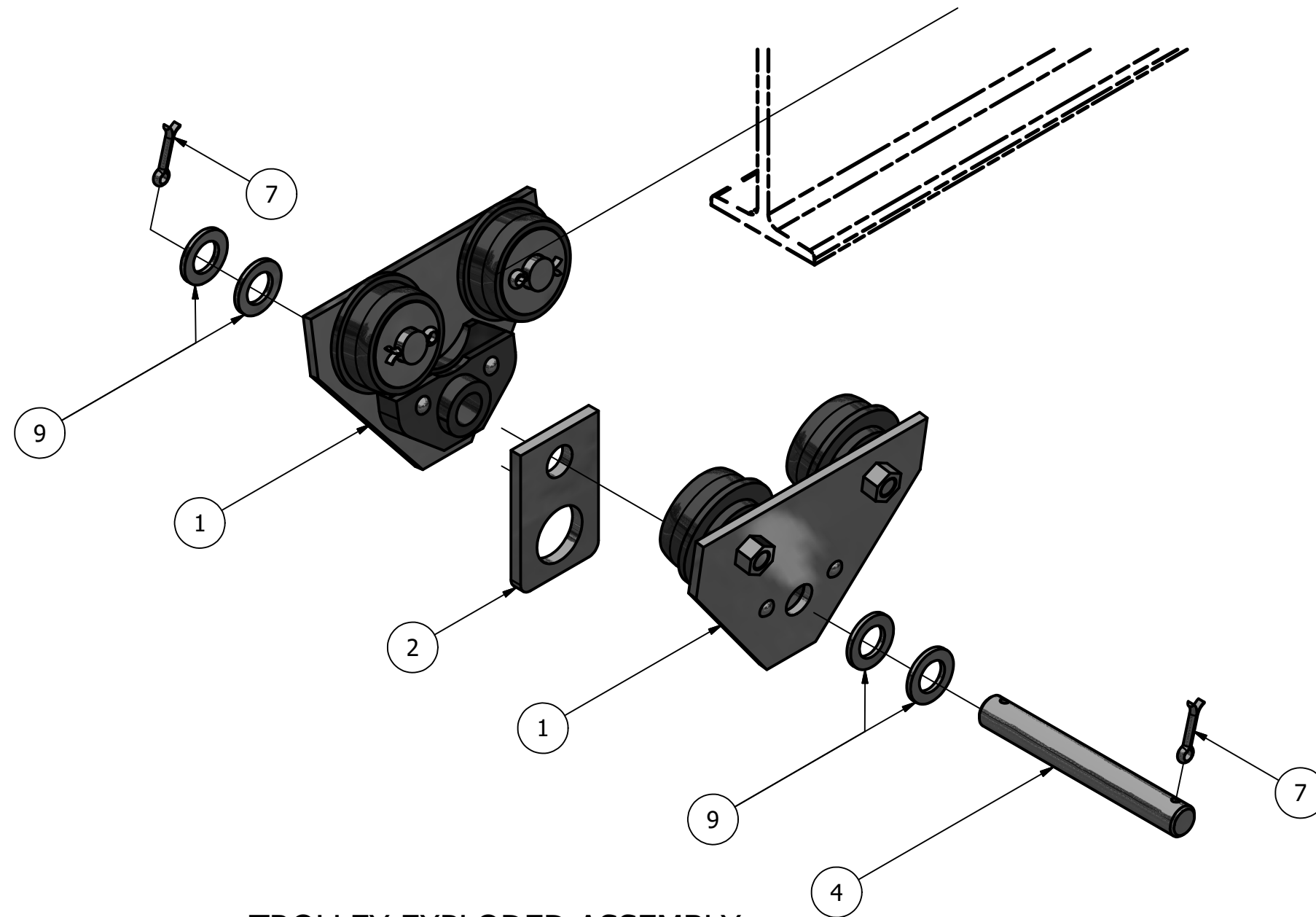

TROLLEY EXPLODED ASSEMBLY
SCALE 1 / 4



DIGITAL DESIGN
GRAPHICS
TECHNOLOGY

WWW.DDGT.NET



(707)208-7773 | dl.sipin@gmail.com | www.ddgt.net/StudentPages/djalotjot

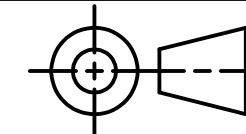

TOLERANCES UNLESS SPECIFIED:
MILLIMETERS:
WHOLE NUMBER = ±.5
X = ±.25
XX = ±.12

ANGLES ±1 DEGREE

SURFACES $\sqrt{32}$

COURSE: DDGT120

INVENTOR DRAWING NAME:
TROLLEY

FIG #: 14-83

DRAFTER: D. JALOTJOT

DATE: 12/6/2017

SCALE: AS NOTED

PAGE #: 3 OF 6

PARTS LIST		
ITEM	QTY	PART NUMBER
1.1	4	SIDE PLATE

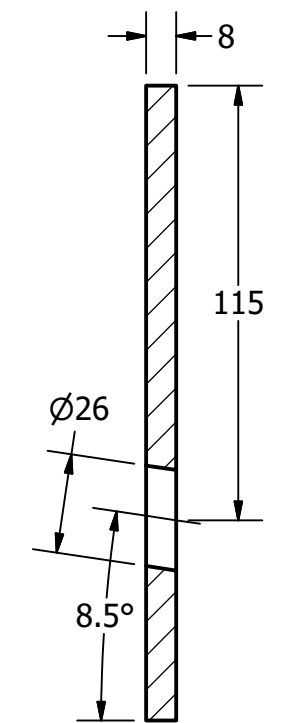

SECTION A-A
SCALE 1 / 2

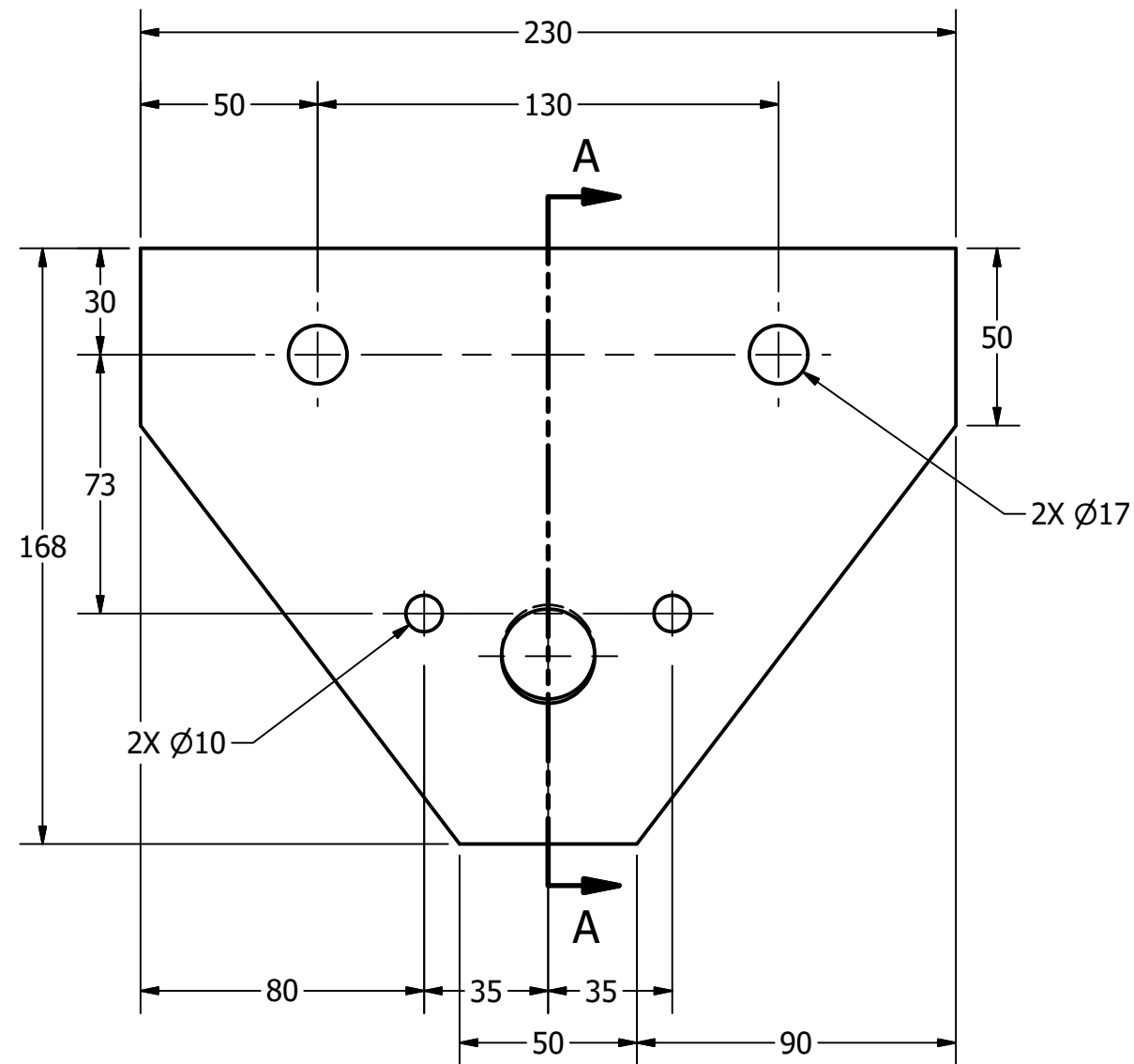

SIDE PLATE
SCALE 1 / 2

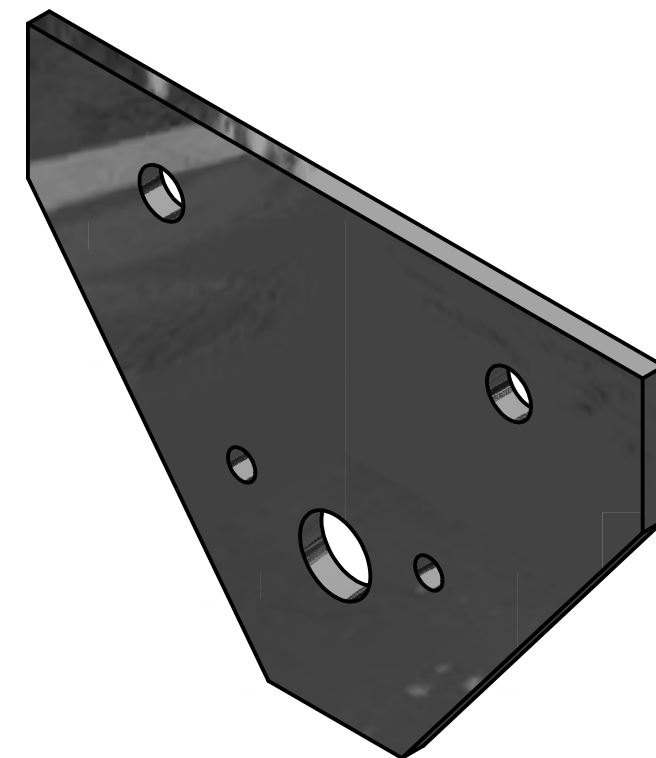

DDGT

DIGITAL DESIGN
GRAPHICS
TECHNOLOGY

WWW.DDGT.NET

dj
Design
&
Animation
by Danielle Jalotjot

(707)208-7773 | dl.sipin@gmail.com | www.ddgt.net/StudentPages/djalotjot

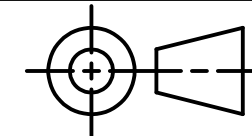

TOLERANCES UNLESS SPECIFIED:
MILLIMETERS:
WHOLE NUMBER = ±.5
X = ±.25
XX = ±.12

ANGLES ±1 DEGREE

SURFACES $\sqrt{32}$

COURSE: DDGT120

INVENTOR DRAWING NAME:
TROLLEY

FIG #: 14-83

DRAFTER: D. JALOTJOT

DATE: 12/6/2017

SCALE: AS NOTED

PAGE #: 4 OF 6

PARTS LIST		
ITEM	QTY	PART NUMBER
1.2	4	GUIDE
2	1	HOOK
6	44	ROLLER BEARING

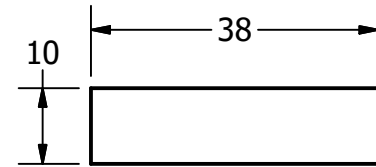

ROLLER BEARING
SCALE 1 : 1

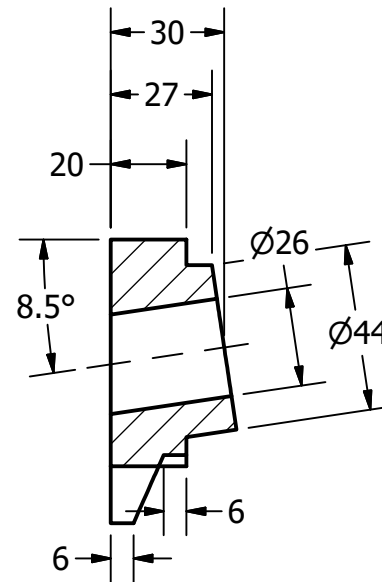
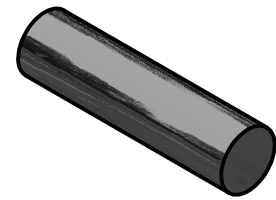

SECTION B-B
SCALE 1 / 2

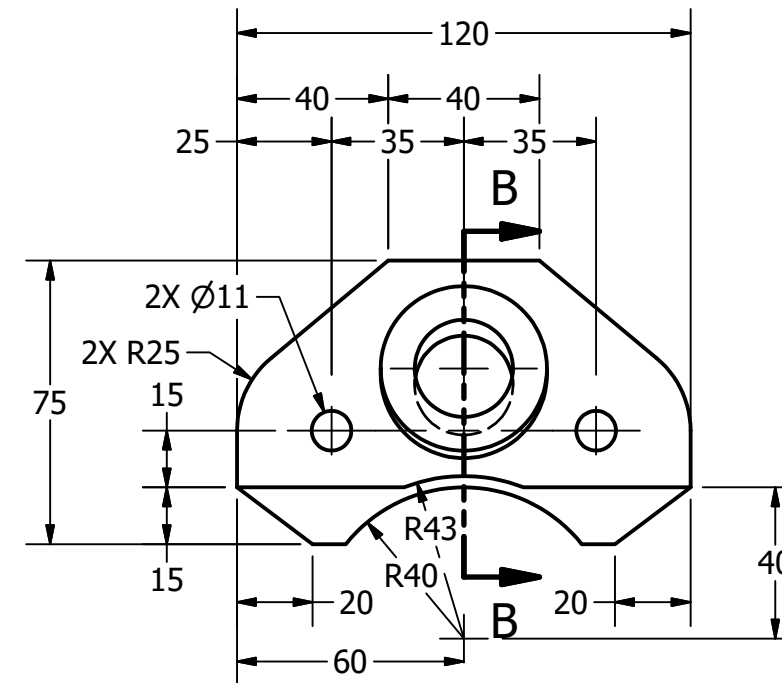

GUIDE
SCALE 1 / 2

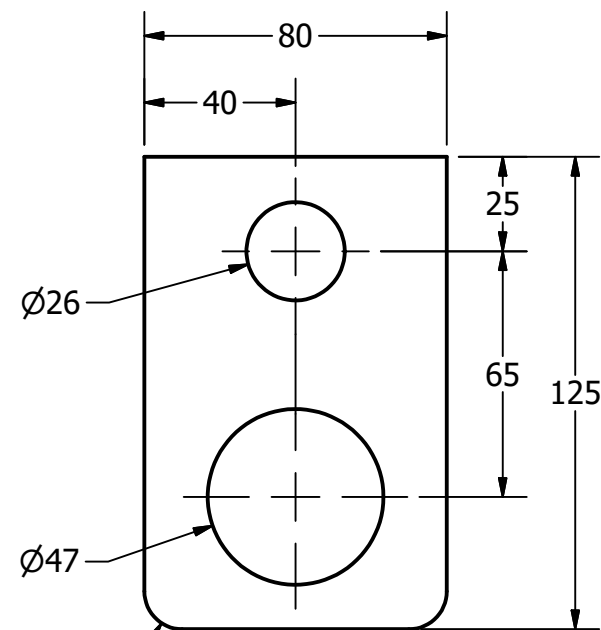
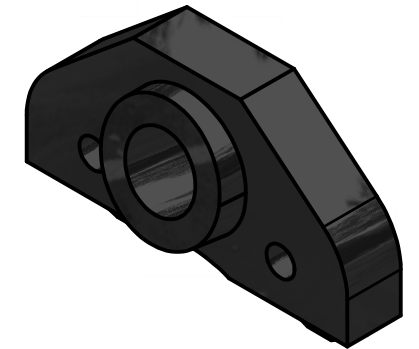

HOOK
SCALE 1 / 2

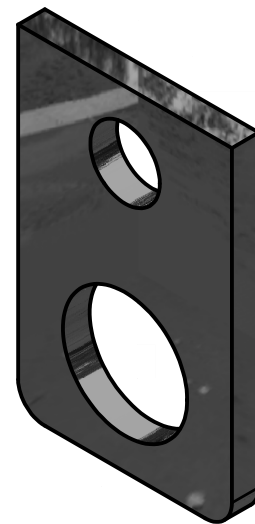

DDGT

DIGITAL DESIGN
GRAPHICS
TECHNOLOGY

WWW.DDGT.NET

dj
Design
&
Animation
by Danielle Jalotjot

(707)208-7773 | dl.sipin@gmail.com | www.ddgt.net/StudentPages/djalotjot

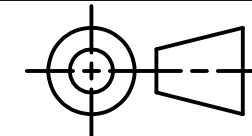

TOLERANCES UNLESS SPECIFIED:
MILLIMETERS:
WHOLE NUMBER = ±.5
X = ±.25
XX = ±.12

ANGLES ±1 DEGREE

SURFACES $\sqrt{32}$

COURSE: DDGT120

INVENTOR DRAWING NAME:

TROLLEY

FIG #: 14-83

DRAFTER: D. JALOTJOT

DATE: 12/6/2017

SCALE: AS NOTED

PAGE #: 5 OF 6

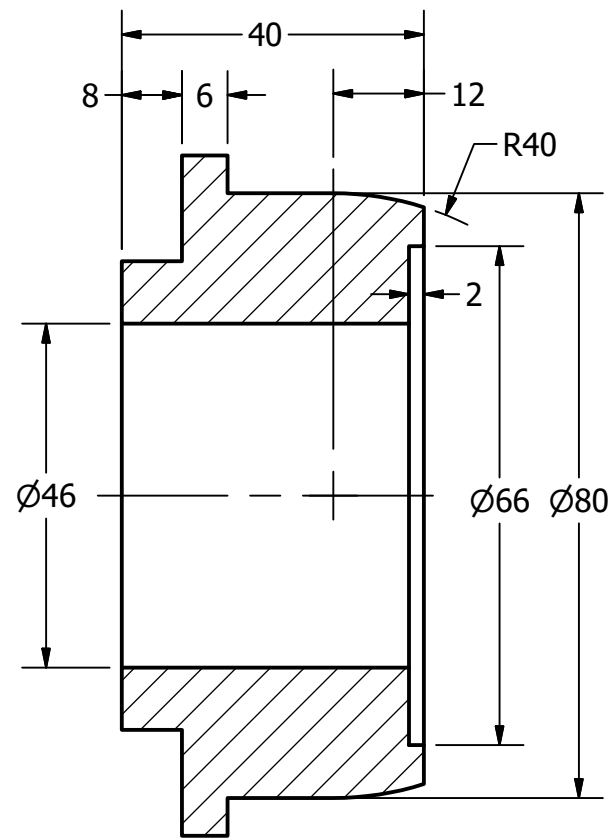

SECTION C-C
SCALE 1 : 1

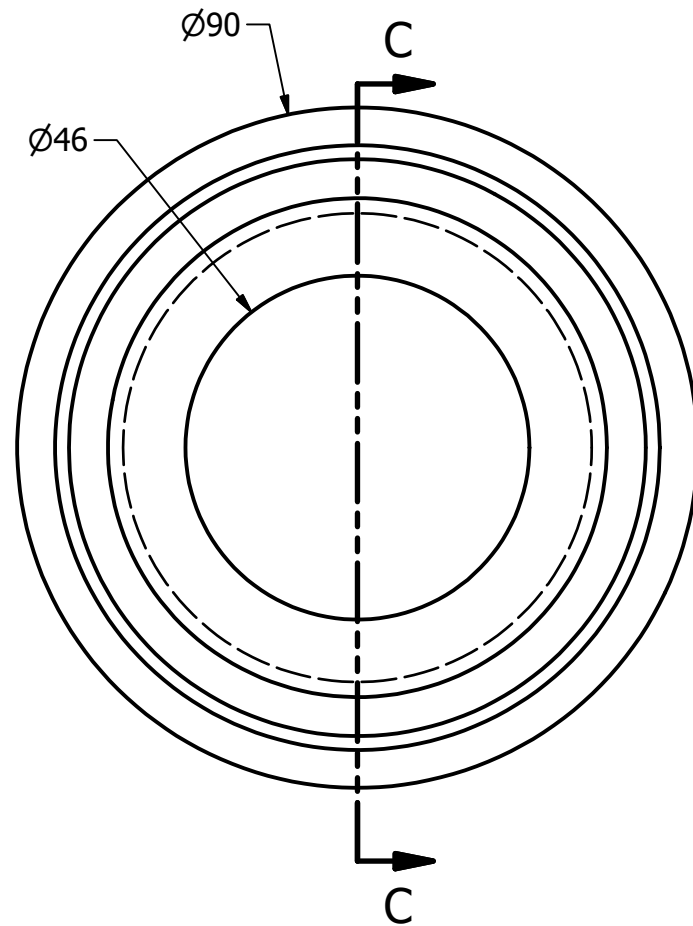

WHEEL
SCALE 1 : 1



PARTS LIST		
ITEM	QTY	PART NUMBER
3	4	WHEEL
4	1	AXLE
5	4	WHEEL AXLE

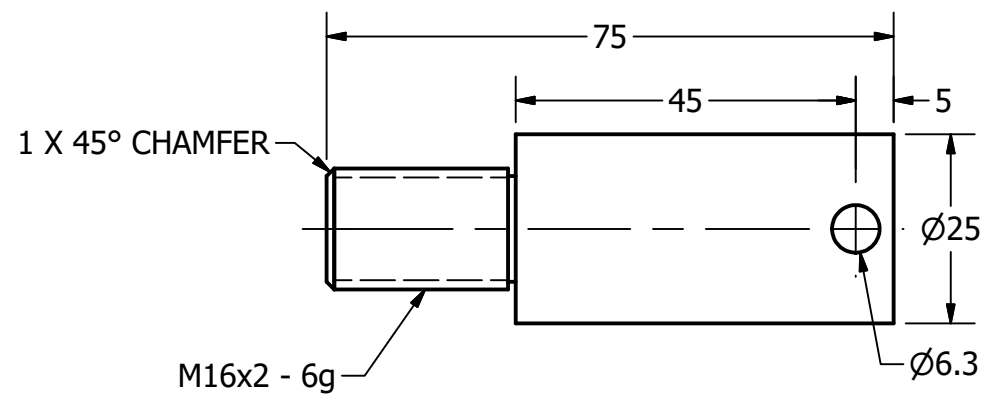

WHEEL AXLE
SCALE 1 : 1

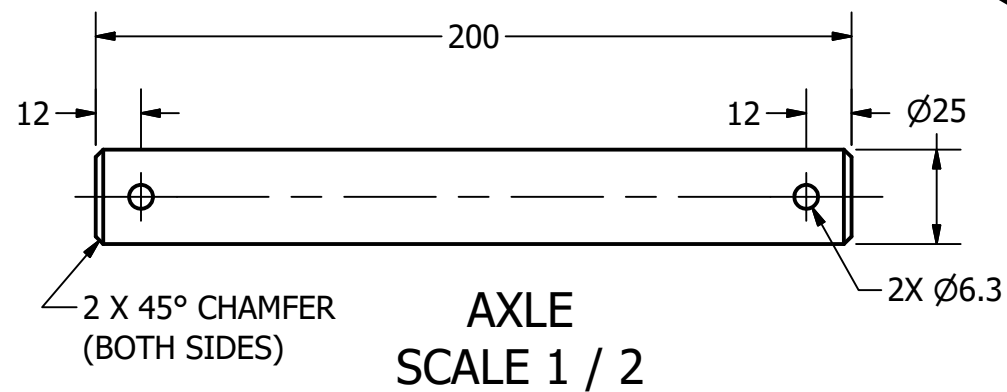
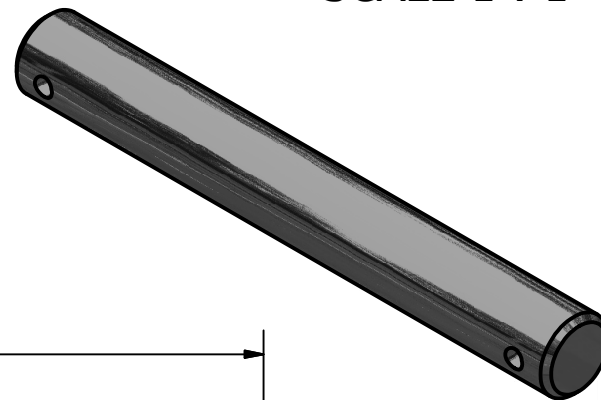
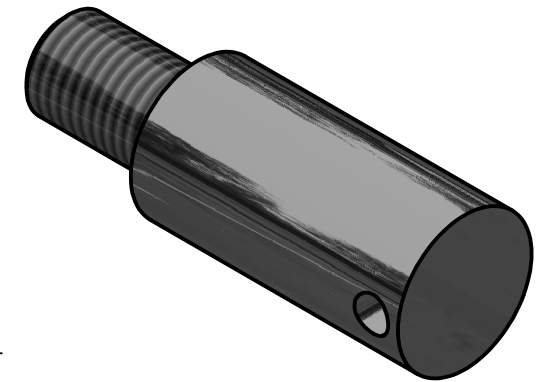

AXLE
SCALE 1 / 2

DDGT

DIGITAL DESIGN
GRAPHICS
TECHNOLOGY

WWW.DDGT.NET

dj
Design
&
Animation
by Danielle Jalotjot

(707)208-7773 | dl.sipin@gmail.com | www.ddgt.net/StudentPages/djalotjot

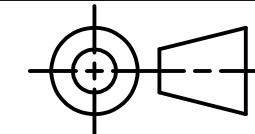

TOLERANCES UNLESS SPECIFIED:
MILLIMETERS:
WHOLE NUMBER = ±.5
X = ±.25
XX = ±.12

ANGLES ±1 DEGREE

SURFACES $\sqrt{32}$

COURSE: DDGT120

INVENTOR DRAWING NAME:
TROLLEY

FIG #: 14-83

DRAFTER: D. JALOTJOT

DATE: 12/6/2017

SCALE: AS NOTED

PAGE #: 6 OF 6