

FIT	BETWEEN PARTS
H8/f7	4 AND 5
H7/p6	3 AND 5
H8/f7	2 AND 4

PARTS LIST			
ITEM	QTY	PART NUMBER	MATERIAL
1	1	TOP PLATE	MALLEABLE IRON
2	1	WHEEL	MALLEABLE IRON
3	2	AXLE SUPPORT	MALLEABLE IRON
4	1	AXLE	SAE 1020
5	2	BUSHING	BRONZE

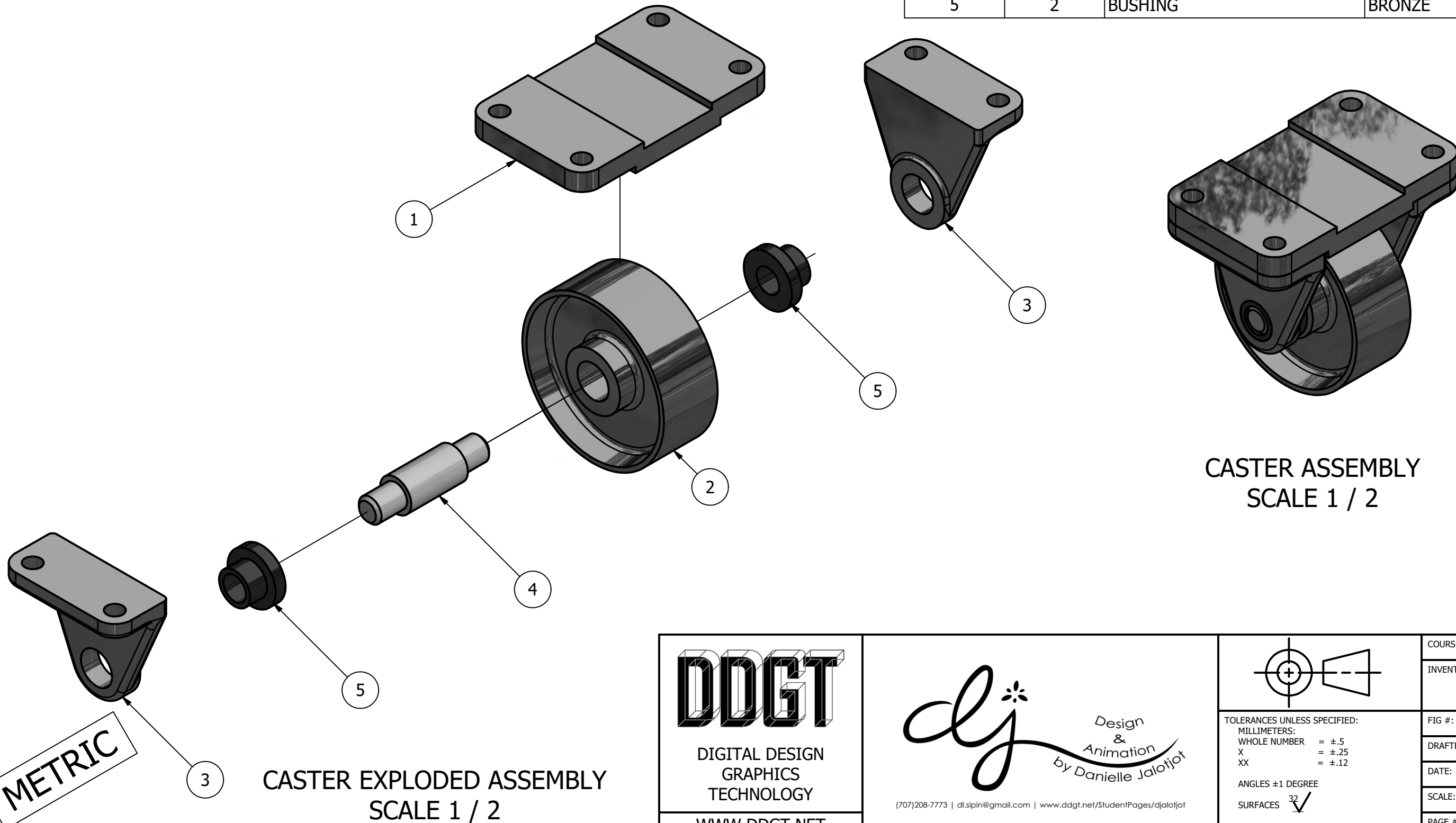

CASTER ASSEMBLY  
SCALE 1 / 2

**LEGEND:**

- ∅ DIAMETER
- R RADIUS
- ° DEGREES
- SPOTFACE



DIGITAL DESIGN  
GRAPHICS  
TECHNOLOGY

WWW.DDGT.NET



(707)208-7773 | dl.sipin@gmail.com | www.ddgt.net/StudentPages/djalotjot

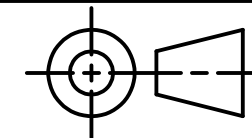

TOLERANCES UNLESS SPECIFIED:  
MILLIMETERS:  
WHOLE NUMBER = ±.5  
X = ±.25  
XX = ±.12

ANGLES ±1 DEGREE

SURFACES  $\sqrt{\text{32}}$

COURSE: DDGT120

INVENTOR DRAWING NAME:  
CASTER

FIG #: 9-51

DRAFTER: D. JALOTJOT

DATE: 11/29/2017

SCALE: AS NOTED

PAGE #: 1 OF 3

PARTS LIST		
ITEM	QTY	PART NUMBER
1	1	TOP PLATE
2	1	WHEEL
4	1	AXLE

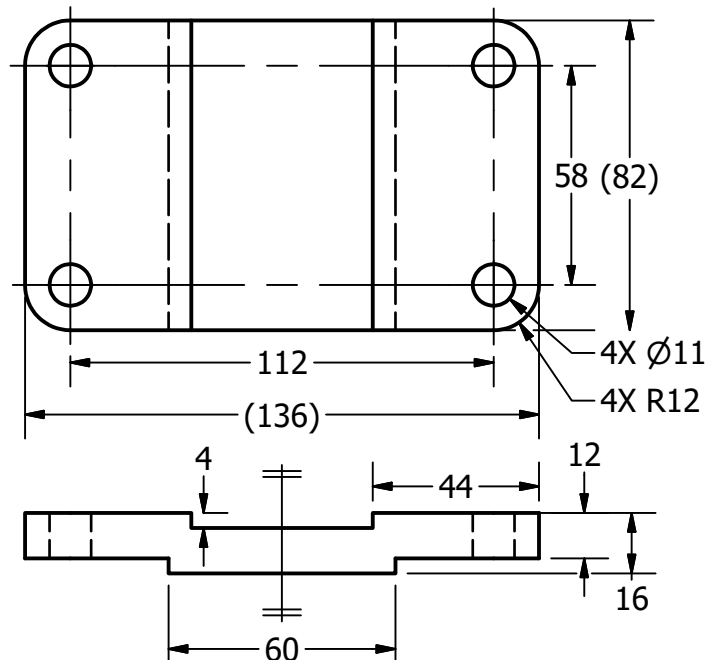

TOP PLATE  
SCALE 1 / 2

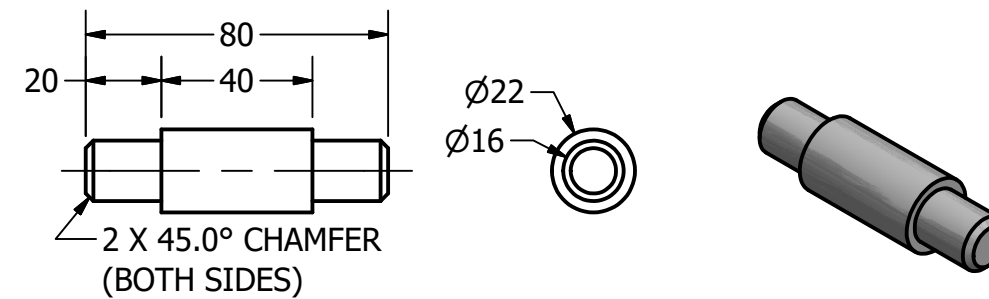
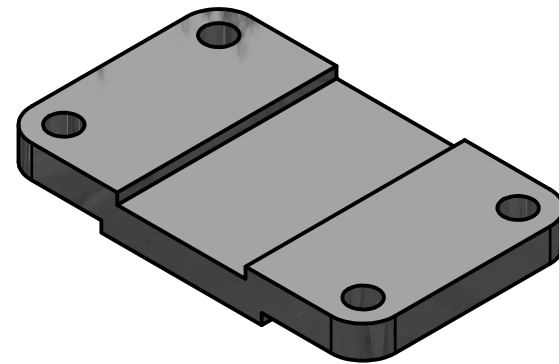

AXLE  
SCALE 1 / 2

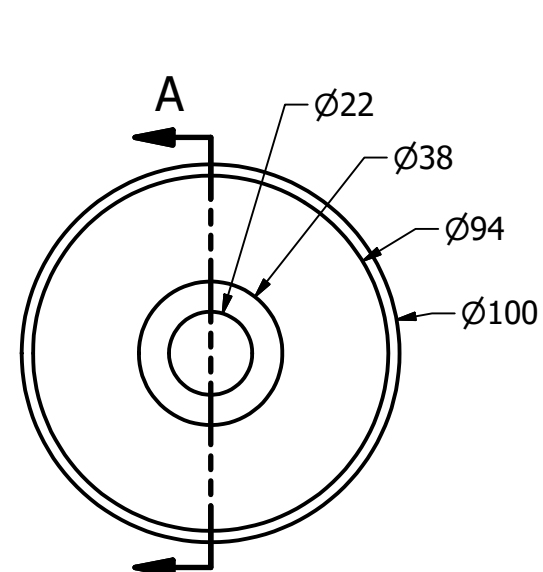

WHEEL  
SCALE 1 / 2

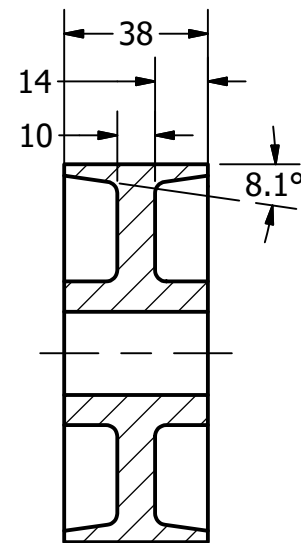

SECTION A-A  
SCALE 1 / 2

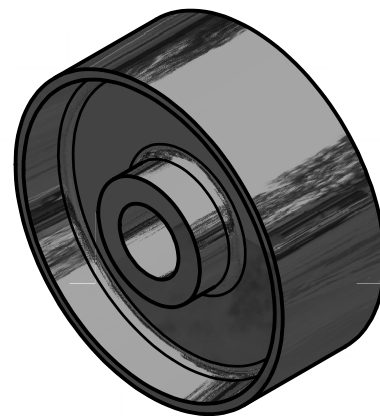

METRIC

**GENERAL NOTES:**  
ALL FILLETS R3 UNLESS OTHERWISE NOTED

**LEGEND:**  
 Ø DIAMETER  
 R RADIUS  
 ° DEGREES  
 □ SPOTFACE

**DDGT**

DIGITAL DESIGN  
GRAPHICS  
TECHNOLOGY

WWW.DDGT.NET

*dj*  
Design  
&  
Animation  
by Danielle Jalotjot

(707)208-7773 | dl.sipin@gmail.com | www.ddgt.net/StudentPages/djalotjot

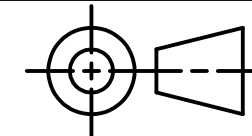

TOLERANCES UNLESS SPECIFIED:  
MILLIMETERS:  
WHOLE NUMBER = ±.5  
X = ±.25  
XX = ±.12

ANGLES ±1 DEGREE

SURFACES  $\sqrt{32}$

COURSE: DDGT120

INVENTOR DRAWING NAME:  
CASTER

FIG #: 9-51

DRAFTER: D. JALOTJOT

DATE: 11/29/2017

SCALE: AS NOTED

PAGE #: 2 OF 3

PARTS LIST		
ITEM	QTY	PART NUMBER
3	2	AXLE SUPPORT
5	2	BUSHING

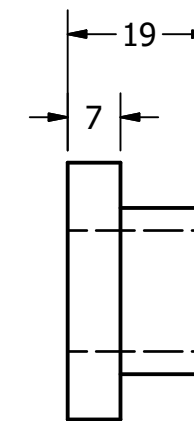
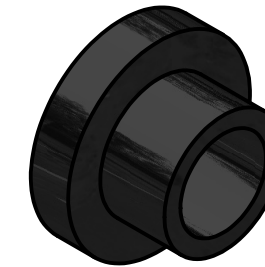
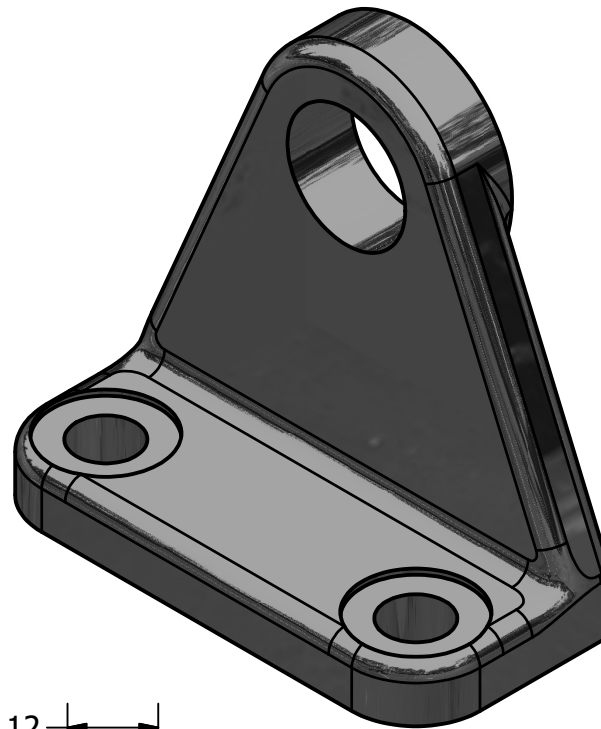
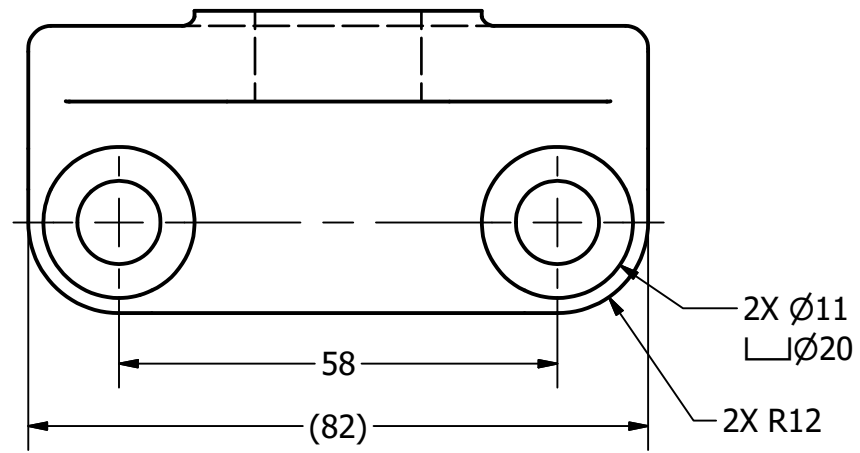

BUSHING  
SCALE 1 : 1

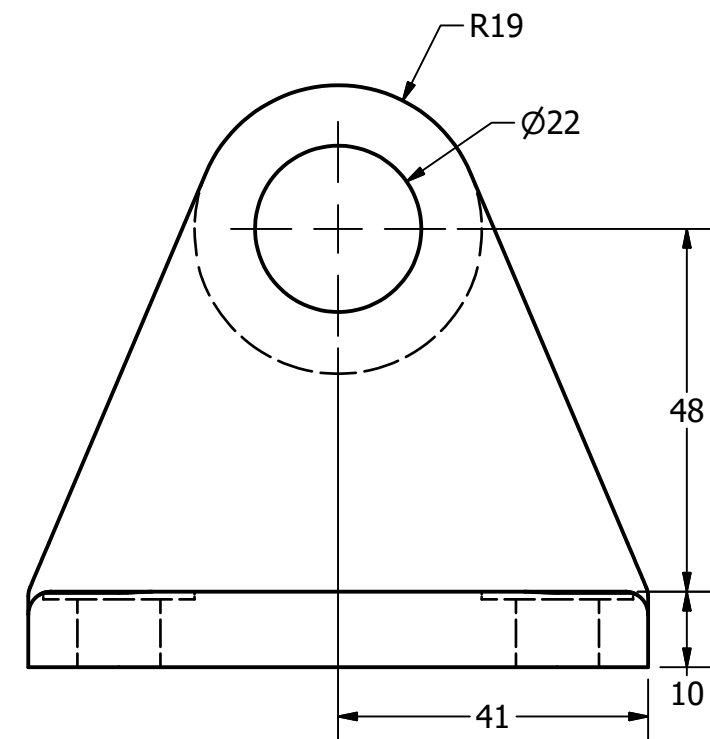
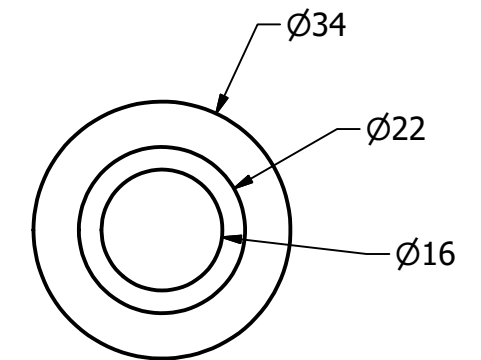

AXLE SUPPORT  
SCALE 1 : 1

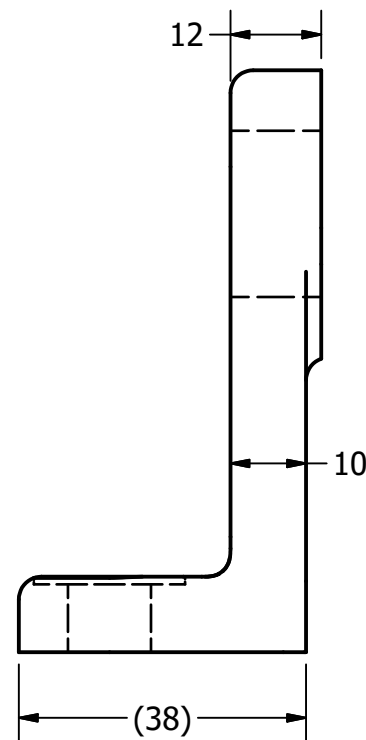

**LEGEND:**

- Ø DIAMETER
- R RADIUS
- ° DEGREES
- ┌ SPOTFACE

METRIC



DIGITAL DESIGN  
GRAPHICS  
TECHNOLOGY

WWW.DDGT.NET



(707)208-7773 | dl.sipin@gmail.com | www.ddgt.net/StudentPages/djalotjot

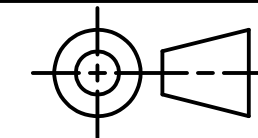

TOLERANCES UNLESS SPECIFIED:  
MILLIMETERS:  
WHOLE NUMBER = ±.5  
X = ±.25  
XX = ±.12

ANGLES ±1 DEGREE

SURFACES  $\sqrt{\text{32}}$

COURSE: DDGT120

INVENTOR DRAWING NAME:  
CASTER

FIG #: 9-51

DRAFTER: D. JALOTJOT

DATE: 11/29/2017

SCALE: AS NOTED

PAGE #: 3 OF 3