

METRIC

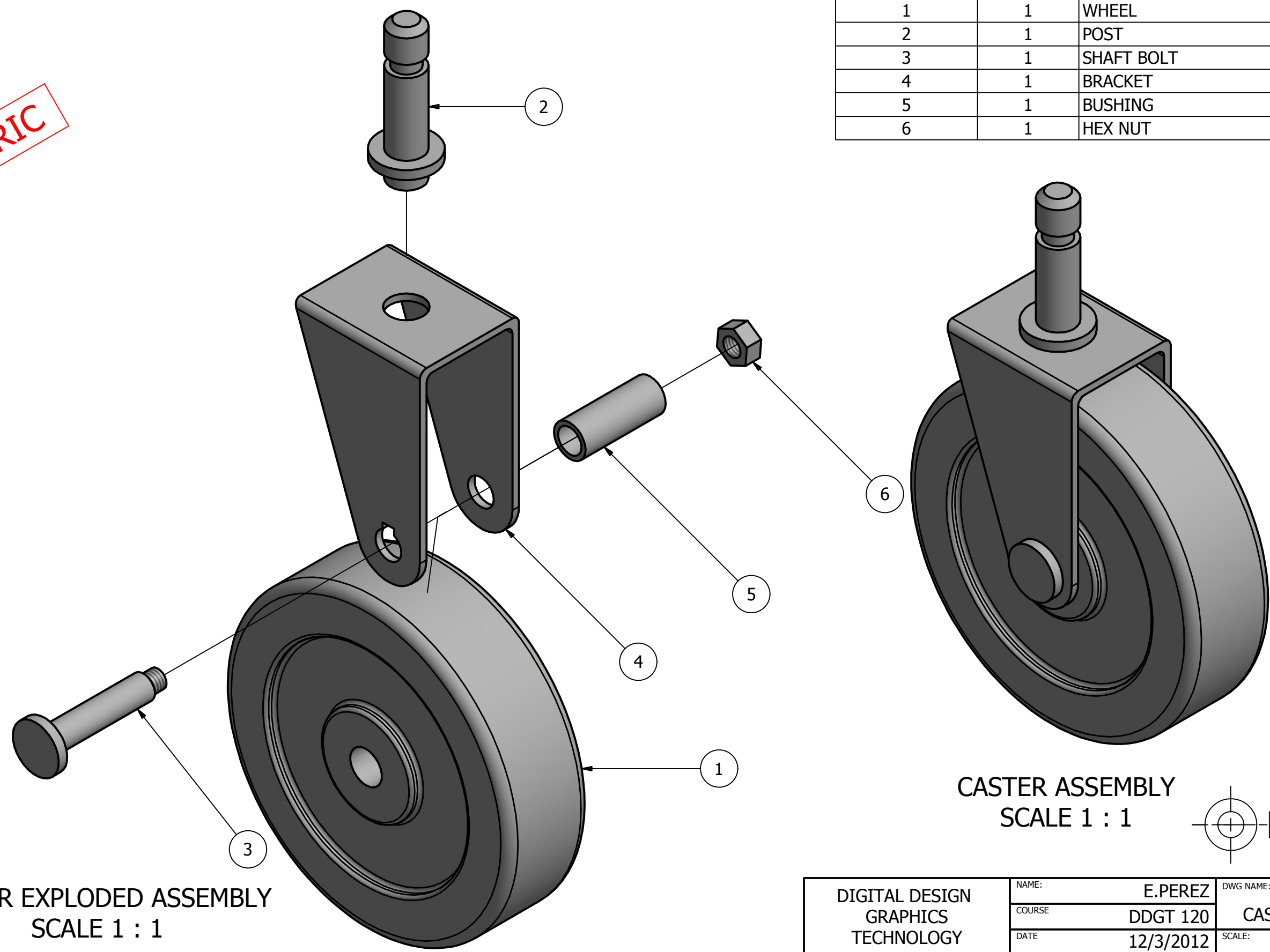

PARTS LIST			
ITEM	QTY	PART NUMBER	DESCRIPTION
1	1	WHEEL	TYP
2	1	POST	TYP
3	1	SHAFT BOLT	M6 ASME B 1.13M
4	1	BRACKET	MATL- 2.29 (NO .13G S GA)
5	1	BUSHING	TYP
6	1	HEX NUT	M6



CASTER EXPLODED ASSEMBLY
SCALE 1 : 1

CASTER ASSEMBLY
SCALE 1 : 1

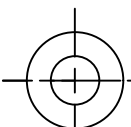
LEGEND

 Ø - DIAMETER
 ° - DEGREES
 R - RADIUS

DIGITAL DESIGN GRAPHICS TECHNOLOGY	NAME:	E.PEREZ	DWG NAME:	12-21	SHEET NO: 1 OF 3
	COURSE:	DDGT 120	CASTER ASSEMBLY		
	DATE:	12/3/2012	SCALE:	AS NOTED:	

PRODUCED BY AN AUTODESK EDUCATIONAL PRODUCT

PRODUCED BY AN AUTODESK EDUCATIONAL PRODUCT

PARTS LIST		
ITEM	QTY	PART NUMBER
1	1	WHEEL
4	1	BRACKET

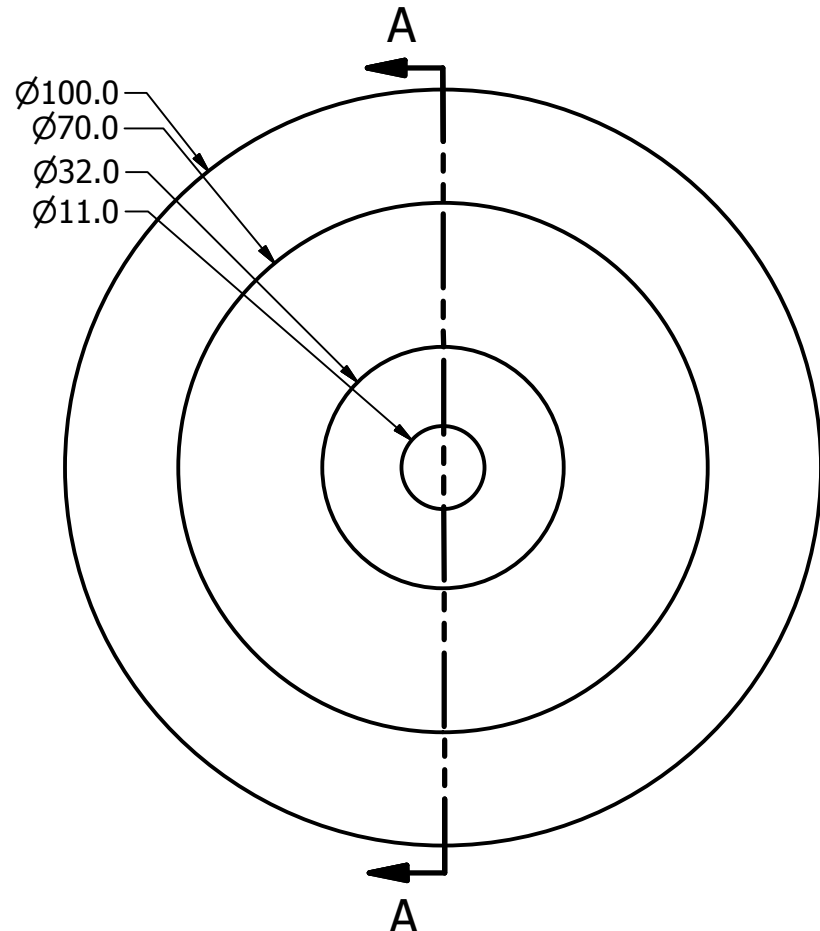
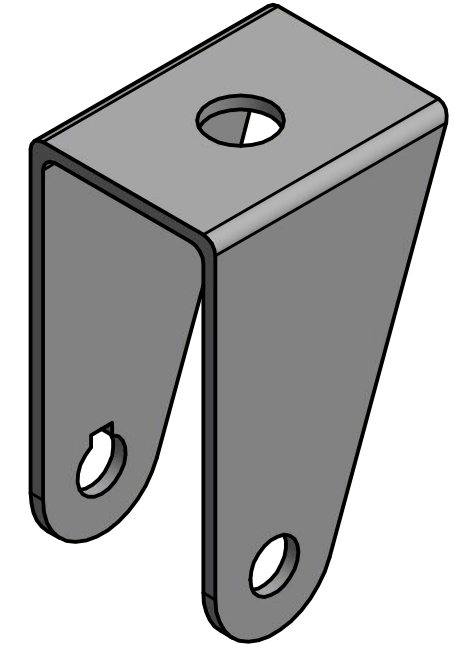
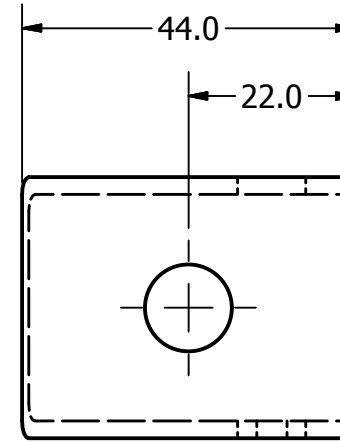
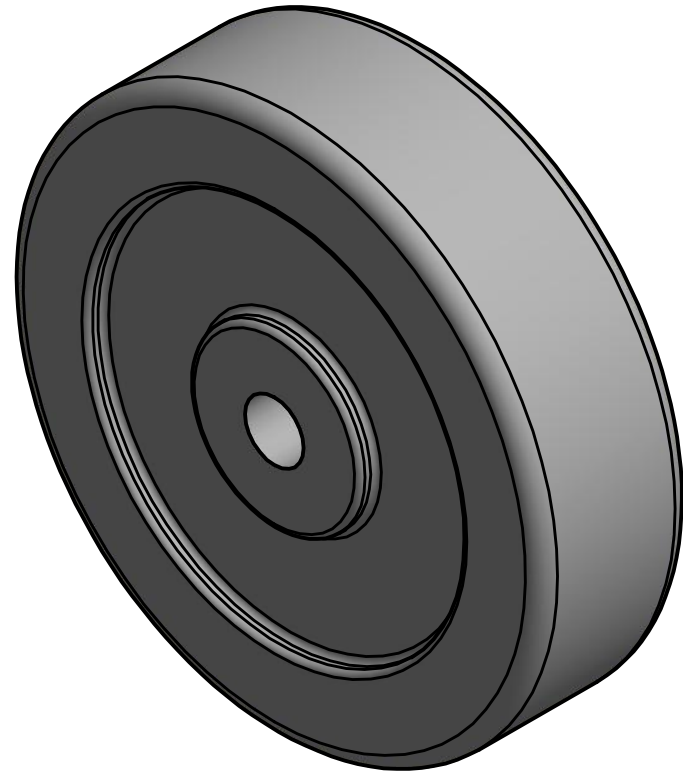

WHEEL
SCALE 1 : 1

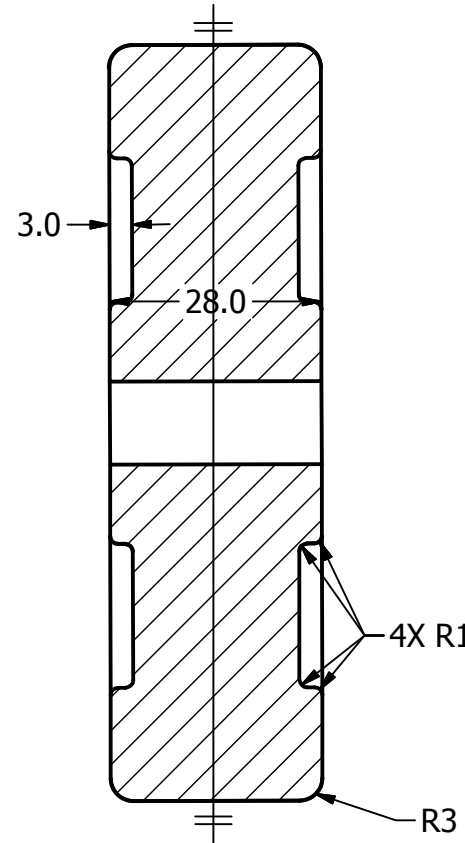

SECTION A-A
SCALE 1 : 1

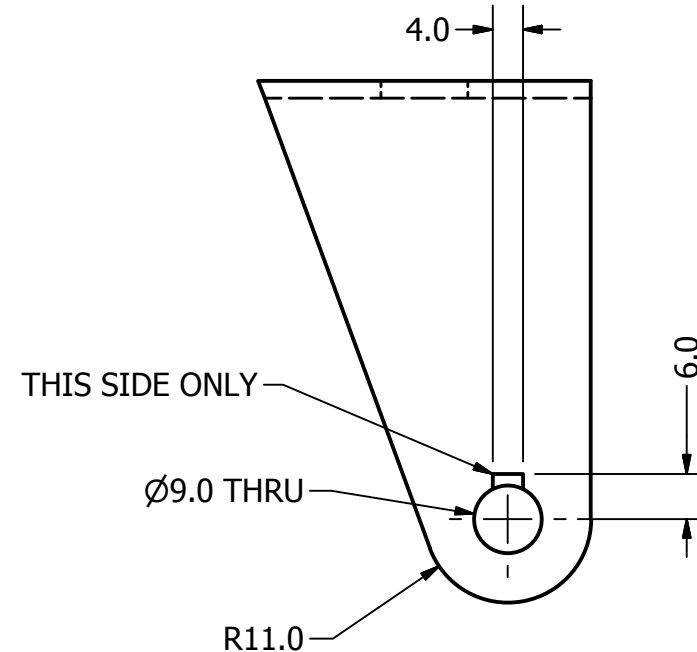

BRACKET
SCALE 1 : 1

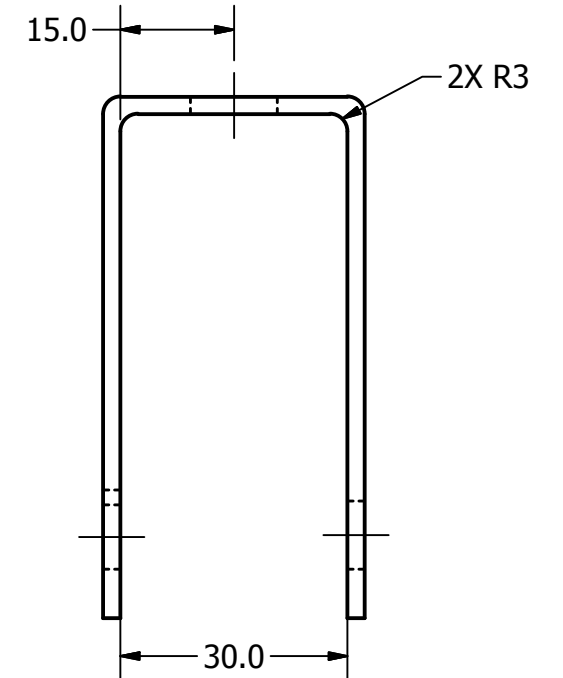

DIGITAL DESIGN GRAPHICS TECHNOLOGY	NAME:	E.PEREZ	DWG NAME:	12-21	SHEET NO: 2 OF 3
	COURSE:	DDGT 120		CASTER ASSEMBLY	
	DATE:	12/3/2012	SCALE:	AS NOTED:	

PARTS LIST		
ITEM	QTY	PART NUMBER
2	1	POST
3	1	SHAFT BOLT
5	1	BUSHING
6	1	HEX NUT

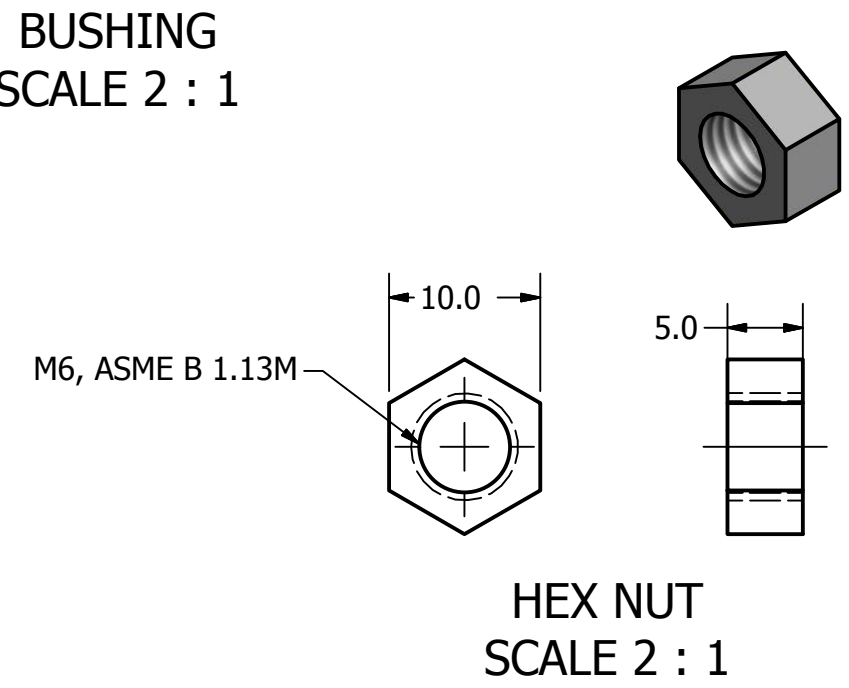
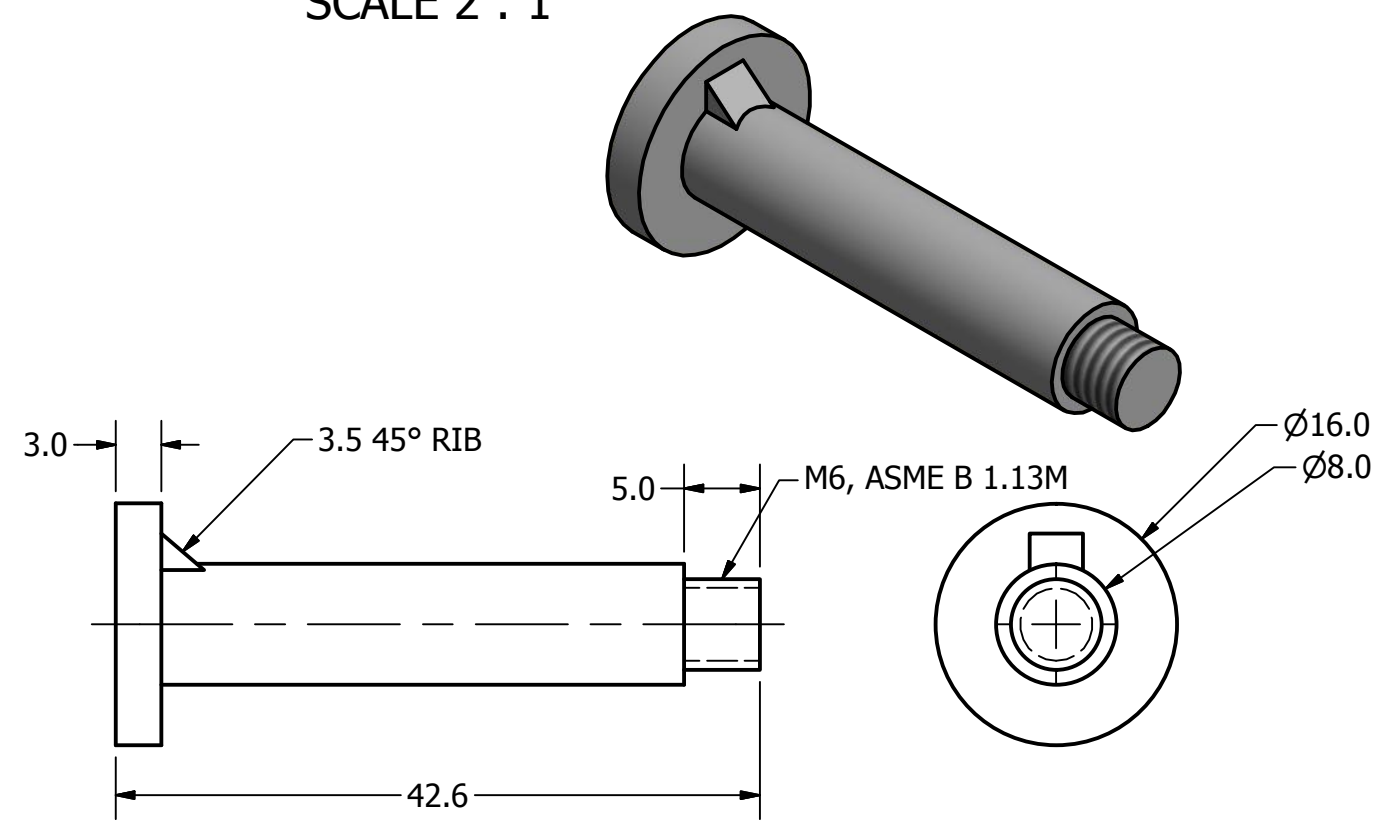
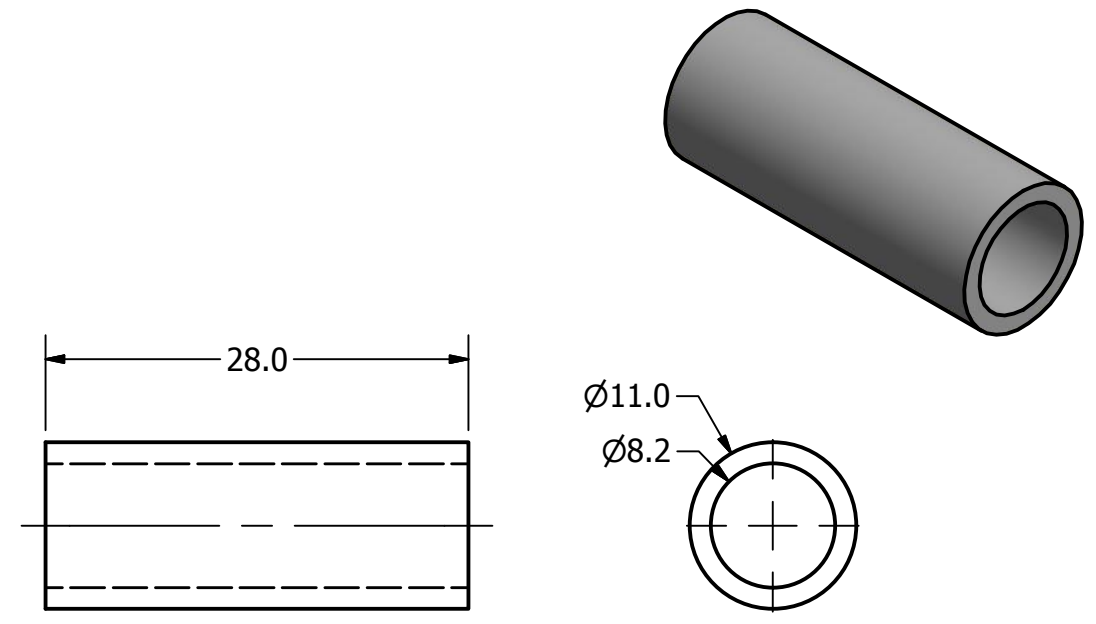
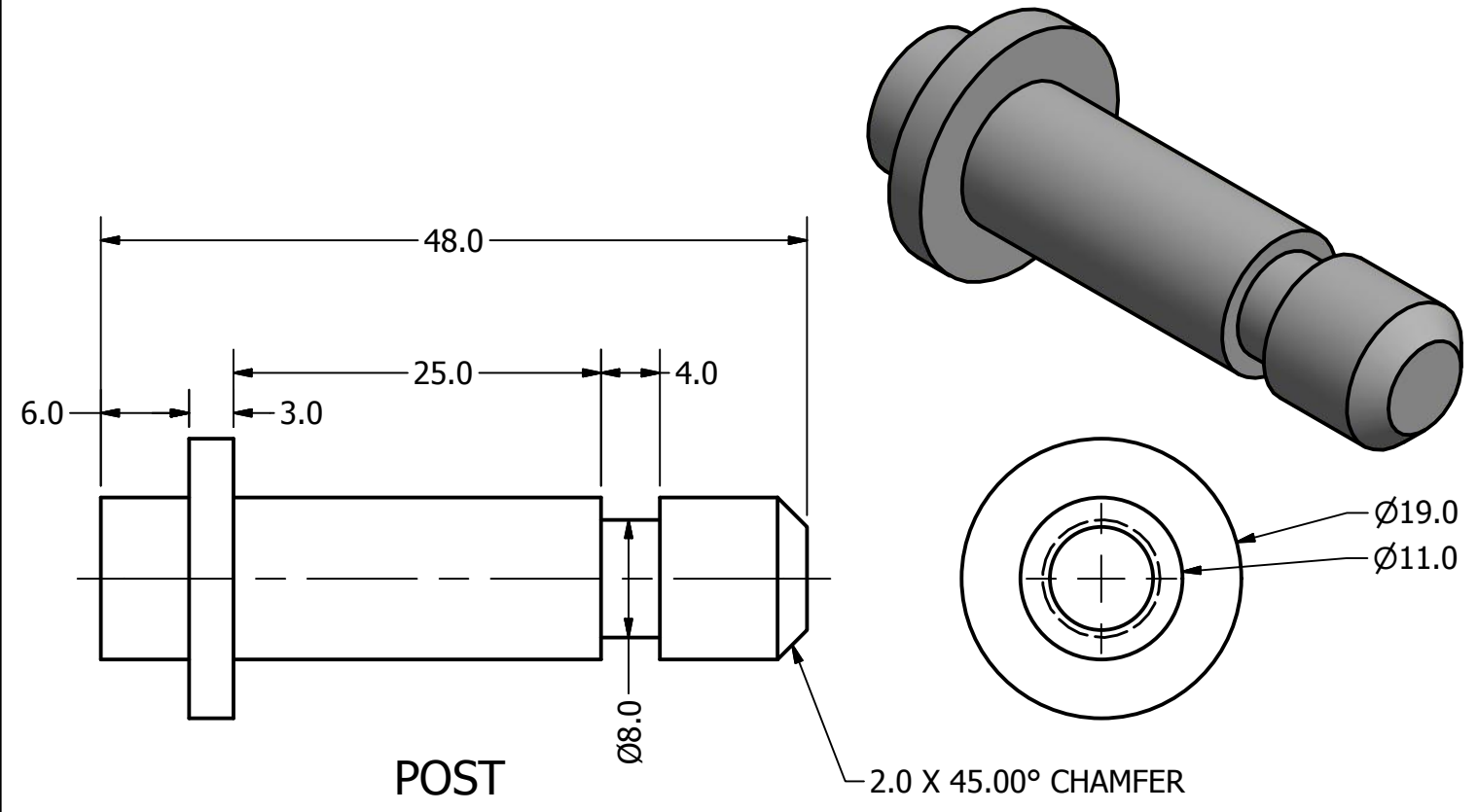

PRODUCED BY AN AUTODESK EDUCATIONAL PRODUCT

PRODUCED BY AN AUTODESK EDUCATIONAL PRODUCT

DIGITAL DESIGN GRAPHICS TECHNOLOGY	NAME:	E.PEREZ	DWG NAME:	12-21	SHEET NO: 3 OF 3
	COURSE:	DDGT 120		CASTER ASSEMBLY	
	DATE:	12/3/2012	SCALE:	AS NOTED:	