

TROLLEY ASSEMBLY
SCALE 1 / 2

PARTS LIST

ITEM	QTY	PART NUMBER	MATERIAL	DESCRIPTION
1	2	SIDE PLATE SUB-ASSEMBLY		
1.1	1	SIDE PLATE	MILD, STEEL	
1.2	1	GUIDE	CAST, IRON	
1.3	2	RIVET	STANDARD	BUTTONHEAD, ø10 X 60 LONG
2	1	AXLE	COLD ROLLED STEEL	
3	1	HOOK	MILD, STEEL	10 THICK
4	44	ROLLER BEARING	COLD ROLLED STEEL	ø10 X 38 LONG
5	4	WHEEL	COLD, IRON	
6	4	WHEEL AXLE	COLD ROLLED STEEL	
7	12	ADJUSTING WASHER	STANDARD	ø26ID X ø44OD X 4 THICK
8	4	WASHER	STANDARD	ø26ID X ø65OD X 3 THICK
9	4	LOCKNUT	STANDARD	M16 x 2 (PREVAILING TORQUE INSERT-TYPE)
10	6	COTTER PIN	STANDARD	ø6 X 40 LONG

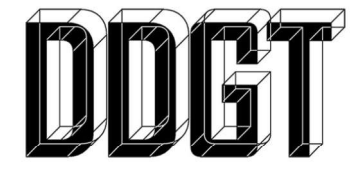

DIGITAL DESIGN
GRAPHIC
TECHNOLOGY

WWW.DDGT.NET

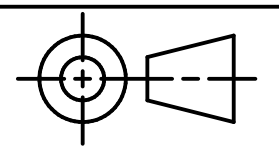

TOLERANCE UNLESS SPECIFIED:
DECIMAL INCHES:
X = ±.020
XX = ±.010
XXX = ±.005
FRACTIONAL ±1/64"
ANGLES ±1 DEGREE
SURFACES ³²✓

METRIC

GENERAL NOTES:

TROLLEY TO BE MOUNTED ON AN S200 X 34 BEAM
ALL CHAMFERS ARE 2 X 2 UNLESS OTHERWISE NOTED

LEGEND:

Ø DIAMETER
R RADIUS
· DEGREE

CLASS:	DDGT120
ASSIGNMENT #:	70
INVENTOR DRAWING NAME:	TROLLEY
FIG #:	14-83
MANAGER:	G. STROMMEN
DRAFTER:	gabri
DATE:	12/12/2022
SCALE:	AS NOTED
PAGE #:	1 OF 6

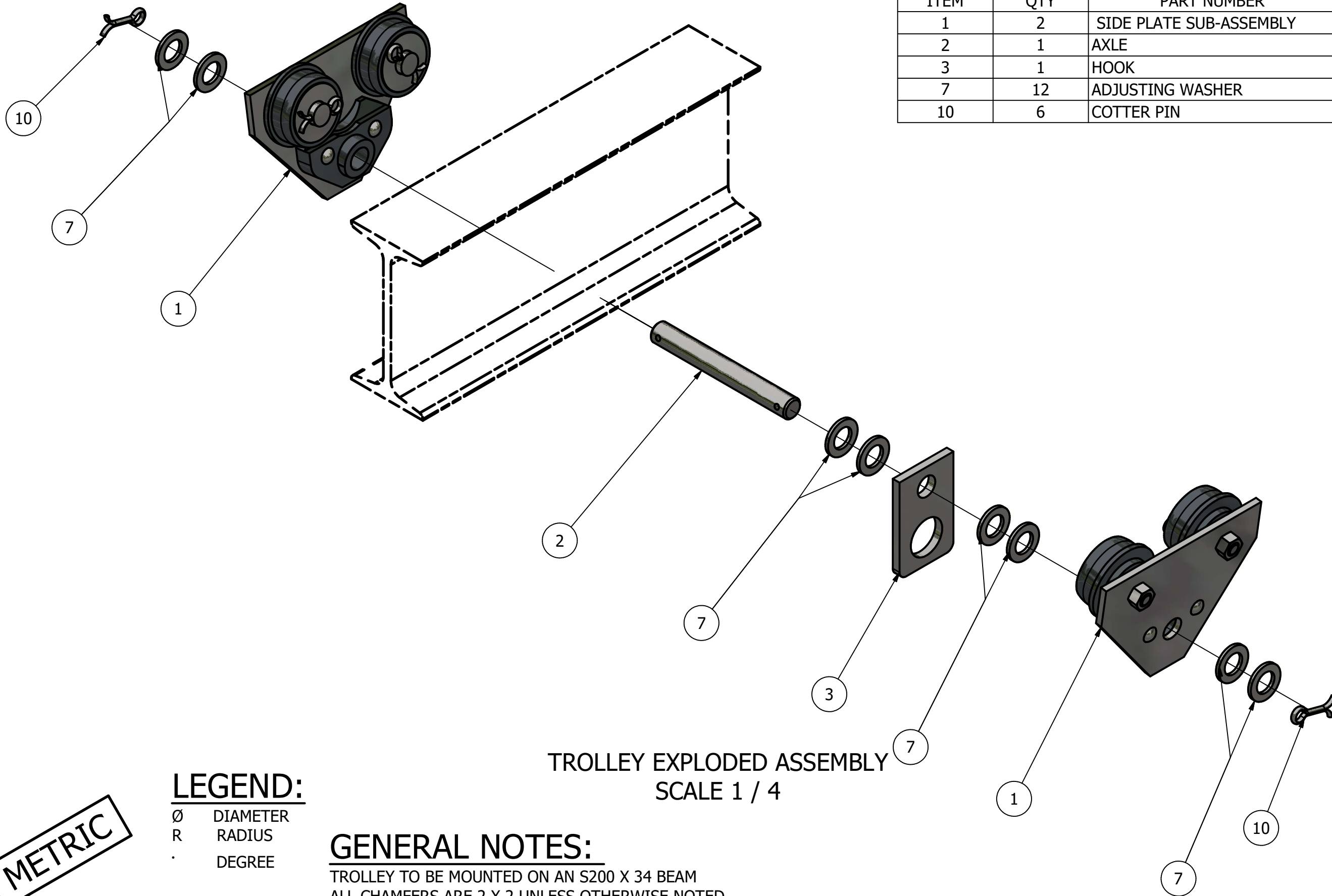

PARTS LIST		
ITEM	QTY	PART NUMBER
1	2	SIDE PLATE SUB-ASSEMBLY
2	1	AXLE
3	1	HOOK
7	12	ADJUSTING WASHER
10	6	COTTER PIN



DIGITAL DESIGN
GRAPHIC
TECHNOLOGY

WWW.DDGT.NET

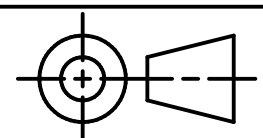

TOLERANCE UNLESS SPECIFIED:
DECIMAL INCHES:
X = ±.020
XX = ±.010
XXX = ±.005
FRACTIONAL ±1/64"
ANGLES ±1 DEGREE
SURFACES ³² ✓

CLASS: DDGT120

ASSIGNMENT #: 70

INVENTOR DRAWING NAME:
TROLLEY

FIG #: 14-83

MANAGER: G. STROMMEN

DRAFTER: gabri

DATE: 12/12/2022

SCALE: AS NOTED

PAGE #: 2 OF 6

METRIC

LEGEND:
∅ DIAMETER
R RADIUS
° DEGREE

GENERAL NOTES:
TROLLEY TO BE MOUNTED ON AN S200 X 34 BEAM
ALL CHAMFERS ARE 2 X 2 UNLESS OTHERWISE NOTED

TROLLEY EXPLODED ASSEMBLY
SCALE 1 / 4

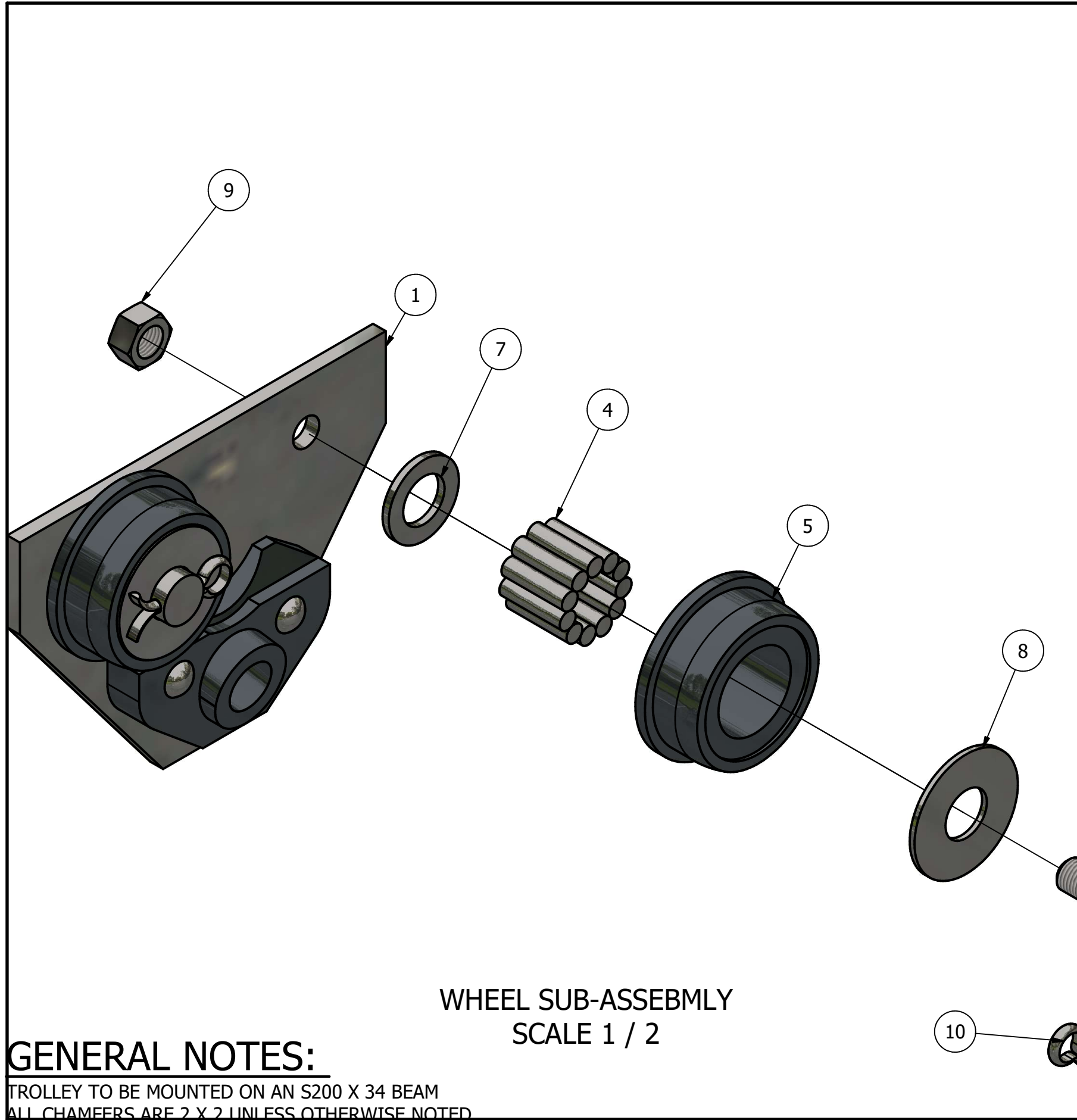

PARTS LIST		
ITEM	QTY	PART NUMBER
1	2	SIDE PLATE SUB-ASSEMBLY
1.1	1	SIDE PLATE
1.2	1	GUIDE
1.3	2	RIVET
4	44	ROLLER BEARING
5	4	WHEEL
6	4	WHEEL AXLE
7	12	ADJUSTING WASHER
8	4	WASHER
9	4	LOCKNUT
10	6	COTTER PIN

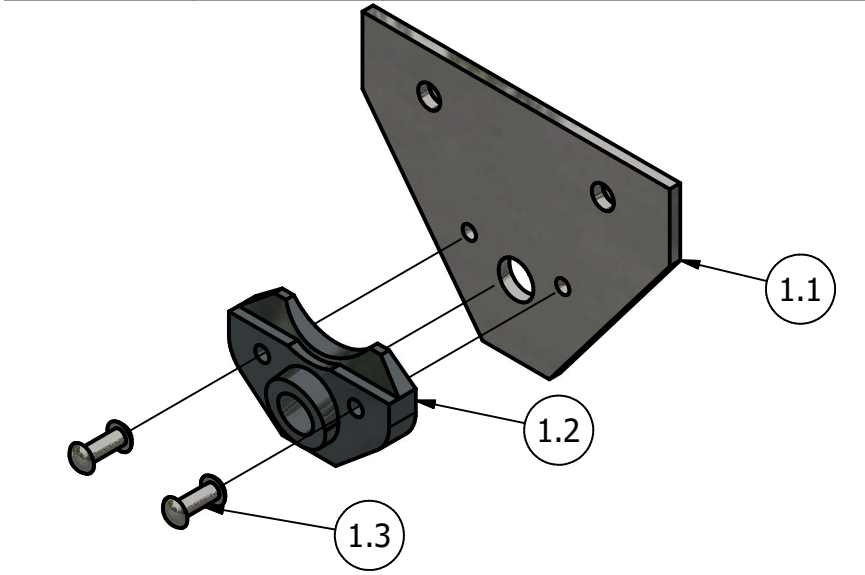

WHEEL SUB-ASSEMBLY
SCALE 1 / 2

SIDE PLATE SUB-ASSEMBLY
SCALE 1 / 4

METRIC

LEGEND:
 Ø DIAMETER
 R RADIUS
 ° DEGREE

GENERAL NOTES:
 TROLLEY TO BE MOUNTED ON AN S200 X 34 BEAM
 ALL CHAMFERS ARE 2 X 2 UNLESS OTHERWISE NOTED

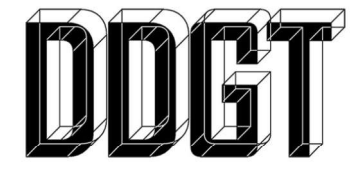

DIGITAL DESIGN
 GRAPHIC
 TECHNOLOGY

WWW.DDGT.NET

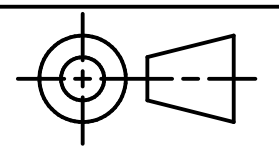

TOLERANCE UNLESS SPECIFIED:
 DECIMAL INCHES:
 X = ±.020
 XX = ±.010
 XXX = ±.005
 FRACTIONAL ±1/64"
 ANGLES ±1 DEGREE
 SURFACES ³²✓

CLASS: DDGT120

ASSIGNMENT #: 70

INVENTOR DRAWING NAME:
 TROLLEY

FIG #: 14-83

MANAGER: G. STROMMEN

DRAFTER: gabri

DATE: 12/12/2022

SCALE: AS NOTED

PAGE #: 3 OF 6

PARTS LIST		
ITEM	QTY	PART NUMBER
1.1	2	SIDE PLATE



DIGITAL DESIGN
GRAPHIC
TECHNOLOGY

WWW.DDGT.NET

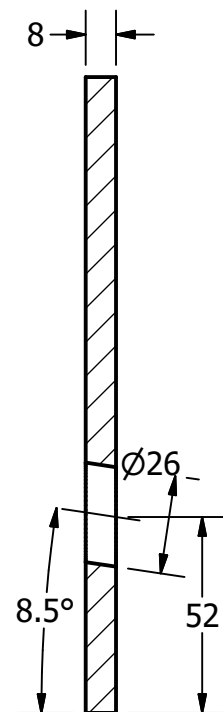
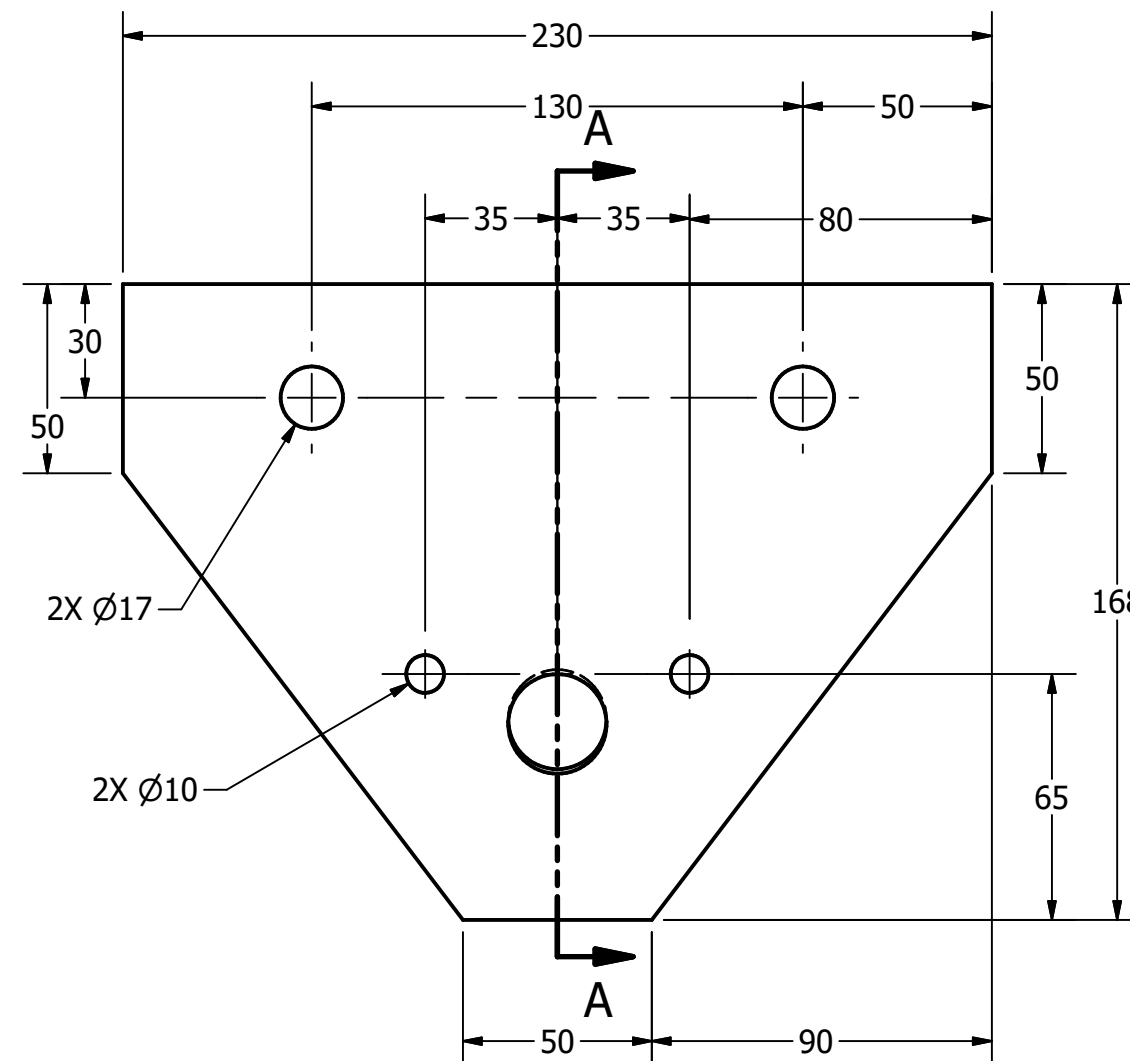
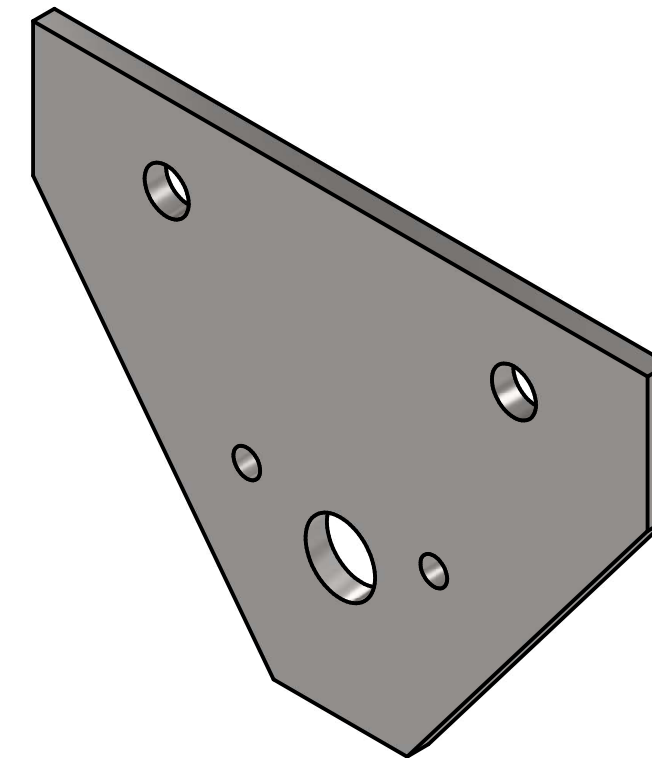

SECTION A-A
SCALE 1 / 2

SIDE PLATE
SCALE 1 / 2

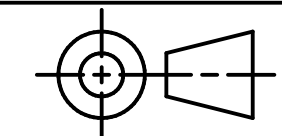

TOLERANCE UNLESS SPECIFIED:
DECIMAL INCHES:
X = ±.020
XX = ±.010
XXX = ±.005
FRACTIONAL ± 1/64"
ANGLES ± 1 DEGREE
SURFACES ³² ✓

CLASS: DDGT120

ASSIGNMENT #: 70

INVENTOR DRAWING NAME:
TROLLEY

FIG #: 14-83

MANAGER: G. STROMMEN

DRAFTER: gabri

DATE: 12/12/2022

SCALE: AS NOTED

PAGE #: 4 OF 6

GENERAL NOTES:

TROLLEY TO BE MOUNTED ON AN S200 X 34 BEAM
ALL CHAMFERS ARE 2 X 2 UNLESS OTHERWISE NOTED

METRIC

LEGEND:

Ø DIAMETER
R RADIUS
° DEGREE

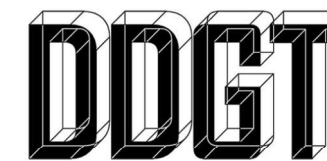

DIGITAL DESIGN
GRAPHIC
TECHNOLOGY

WWW.DDGT.NET

PARTS LIST		
ITEM	QTY	PART NUMBER
1.2	2	GUIDE
2	1	AXLE

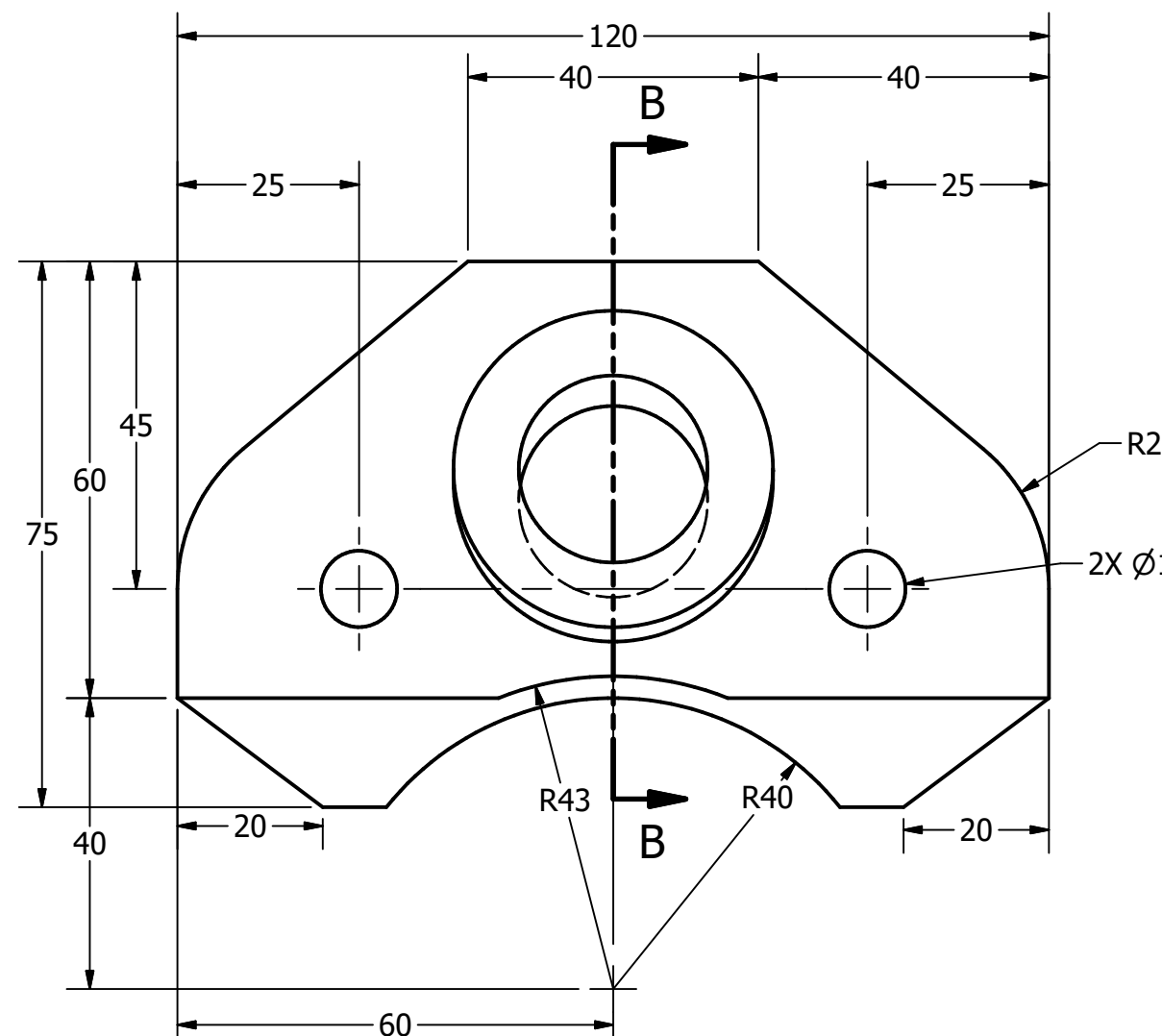
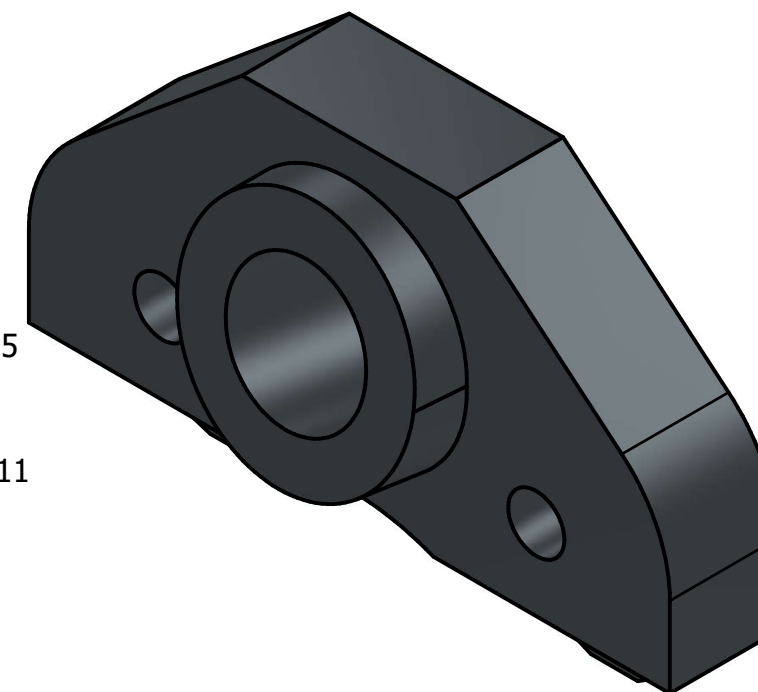

GUIDE
SCALE 1 : 1

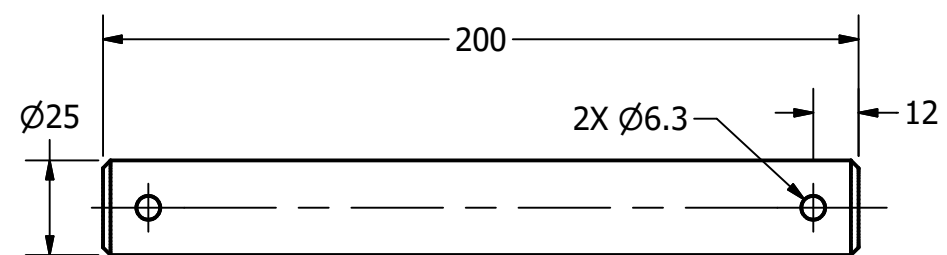

AXLE
SCALE 1 / 2

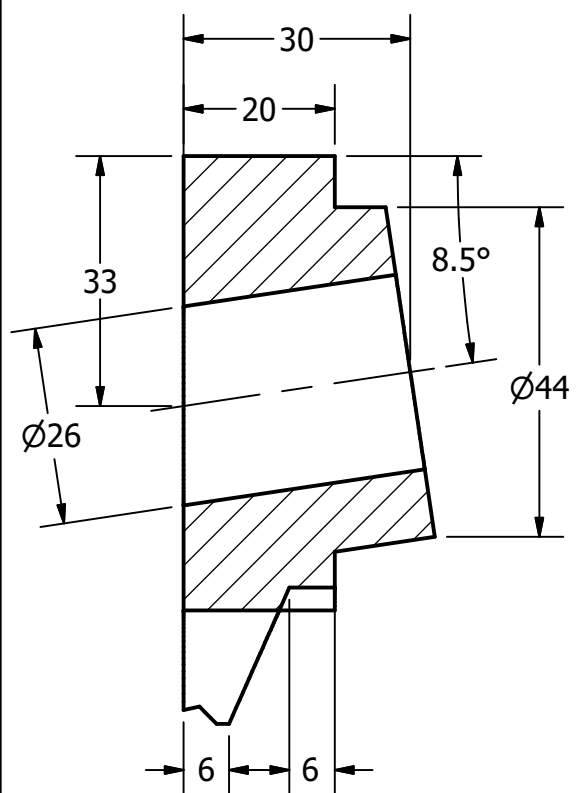

SECTION B-B
SCALE 1 : 1

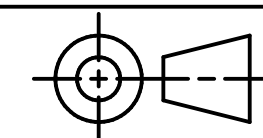

TOLERANCE UNLESS SPECIFIED:
 DECIMAL INCHES:
 X = ±.020
 XX = ±.010
 XXX = ±.005
 FRACTIONAL ±1/64"
 ANGLES ±1 DEGREE
 SURFACES ³²✓

CLASS: DDGT120

ASSIGNMENT #: 70

INVENTOR DRAWING NAME:
TROLLEY

FIG #: 14-83

MANAGER: G. STROMMEN

DRAFTER: gabri

DATE: 12/12/2022

SCALE: AS NOTED

PAGE #: 5 OF 6

METRIC

LEGEND:
 Ø DIAMETER
 R RADIUS
 ° DEGREE

GENERAL NOTES:

TROLLEY TO BE MOUNTED ON AN S200 X 34 BEAM
ALL CHAMFERS ARE 2 X 2 UNLESS OTHERWISE NOTED

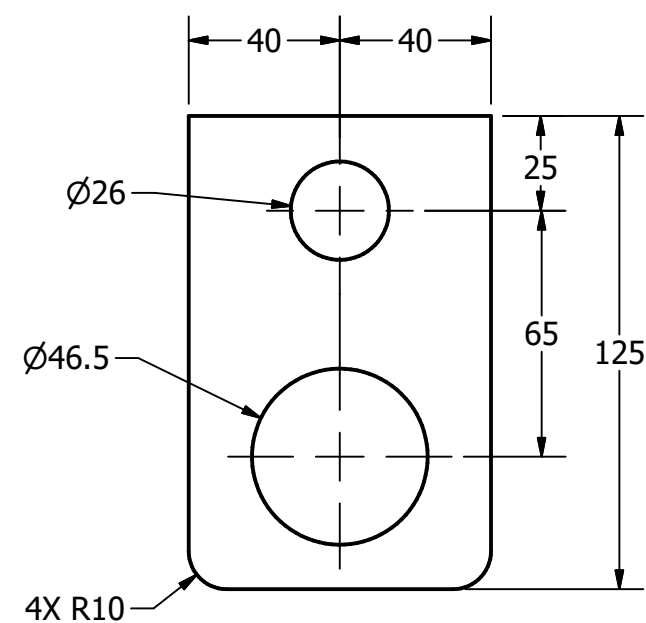

HOOK
SCALE 1 / 2

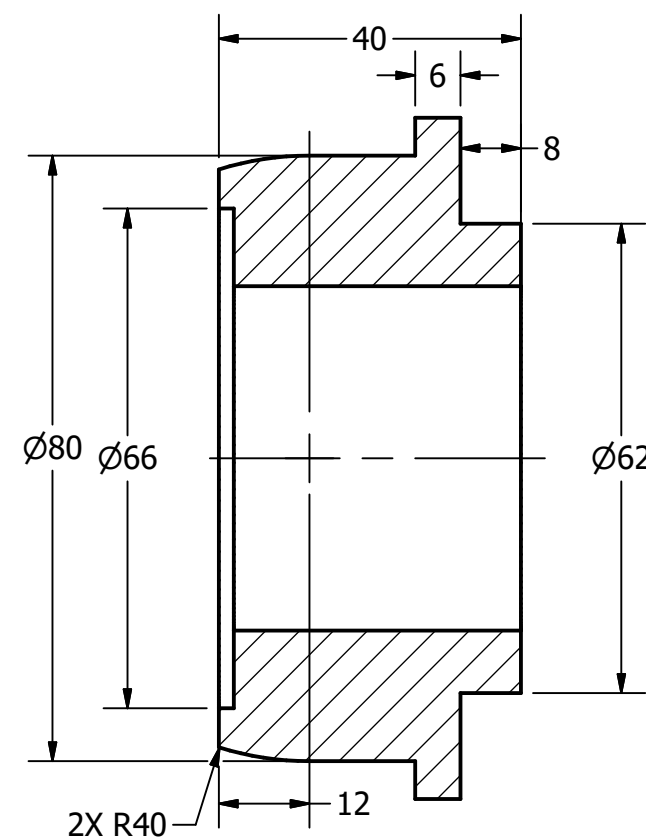

SECTION C-C
SCALE 1 : 1

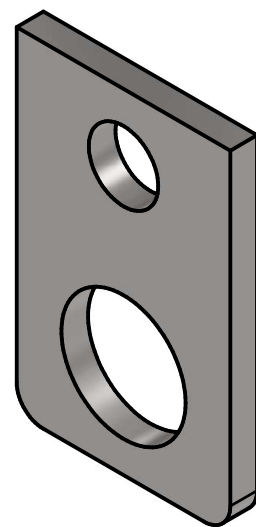

GENERAL NOTES:

TROLLEY TO BE MOUNTED ON AN S200 X 34 BEAM
ALL CHAMFERS ARE 2 X 2 UNLESS OTHERWISE NOTED

PARTS LIST

ITEM	QTY	PART NUMBER
3	1	HOOK
5	4	WHEEL
6	4	WHEEL AXLE

METRIC

LEGEND:

Ø DIAMETER
R RADIUS
° DEGREE

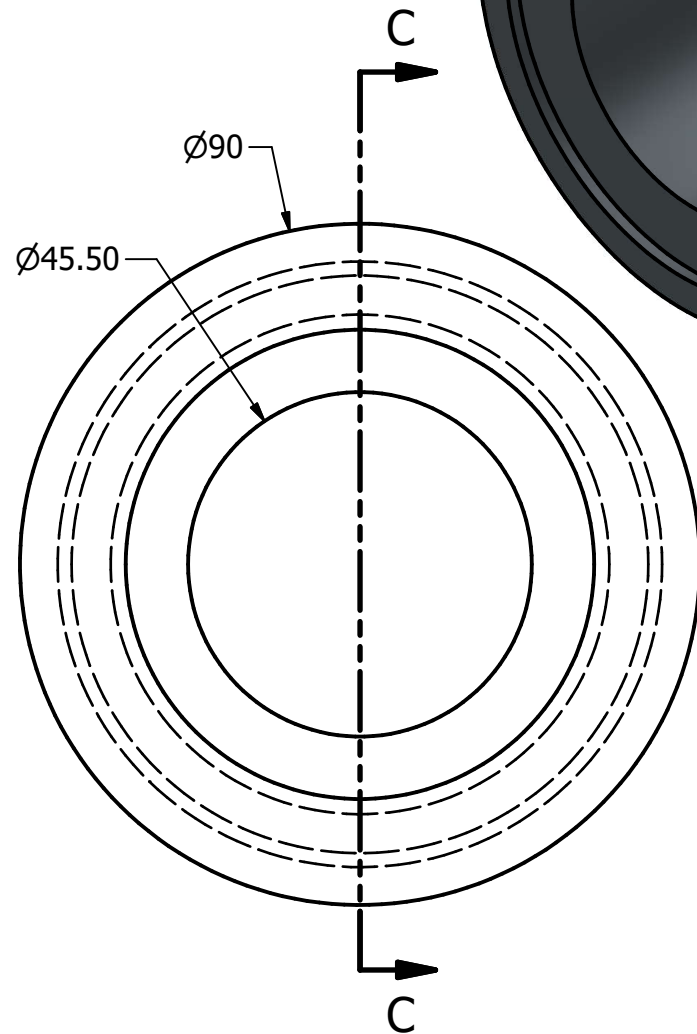
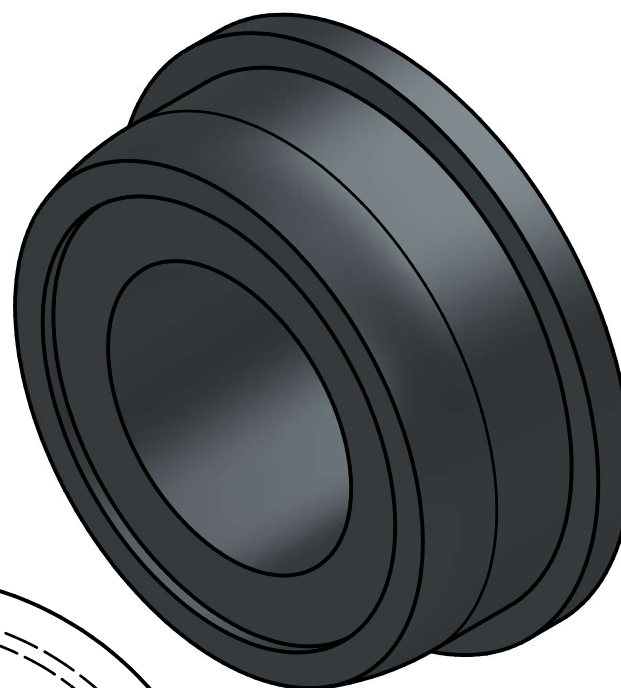

WHEEL
SCALE 1 : 1

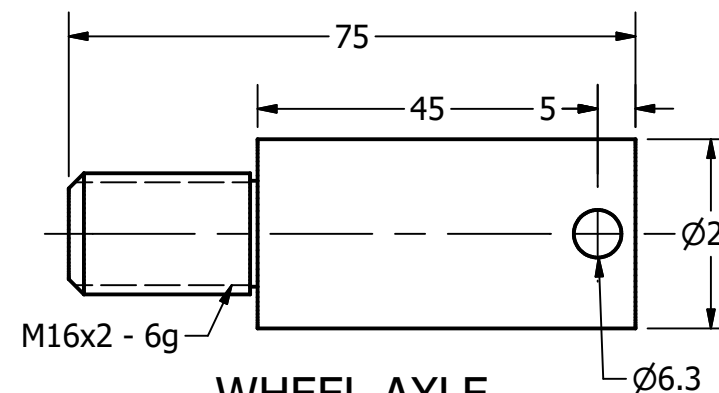
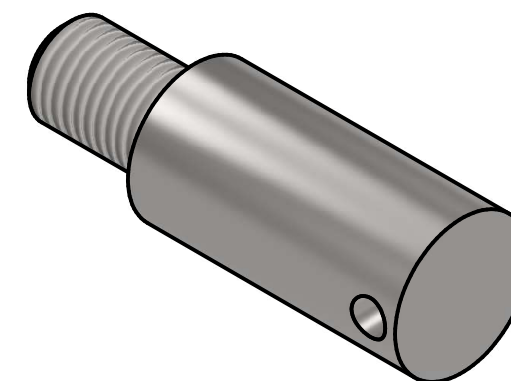

WHEEL AXLE
SCALE 1 : 1

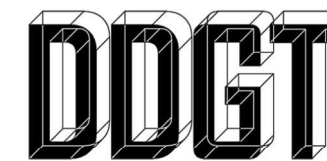

DIGITAL DESIGN
GRAPHIC
TECHNOLOGY

WWW.DDGT.NET

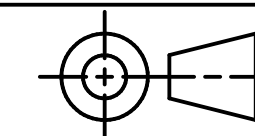

TOLERANCE UNLESS SPECIFIED:
DECIMAL INCHES:
X = ±.020
XX = ±.010
XXX = ±.005
FRACTIONAL ±1/64"
ANGLES ±1 DEGREE
SURFACES ³²✓

CLASS: DDGT120

ASSIGNMENT #: 70

INVENTOR DRAWING NAME:
TROLLEY

FIG #: 14-83

MANAGER: G. STROMMEN

DRAFTER: gabri

DATE: 12/12/2022

SCALE: AS NOTED

PAGE #: 6 OF 6