

PARTS LIST

ITEM	QTY	PART NUMBER	MATERIAL	DESCRIPTION
1	1	BRACKET	USS STEEL	13 GA (2.38)
2	1	SHAFT	SAE 1112	
3	1	RETAINING RING	STEEL	EXT SERIES 5133
4	1	POST	SAE 1112	
5	1	BUSHING	BRASS	
6	1	WHEEL	HARD RUBBER	

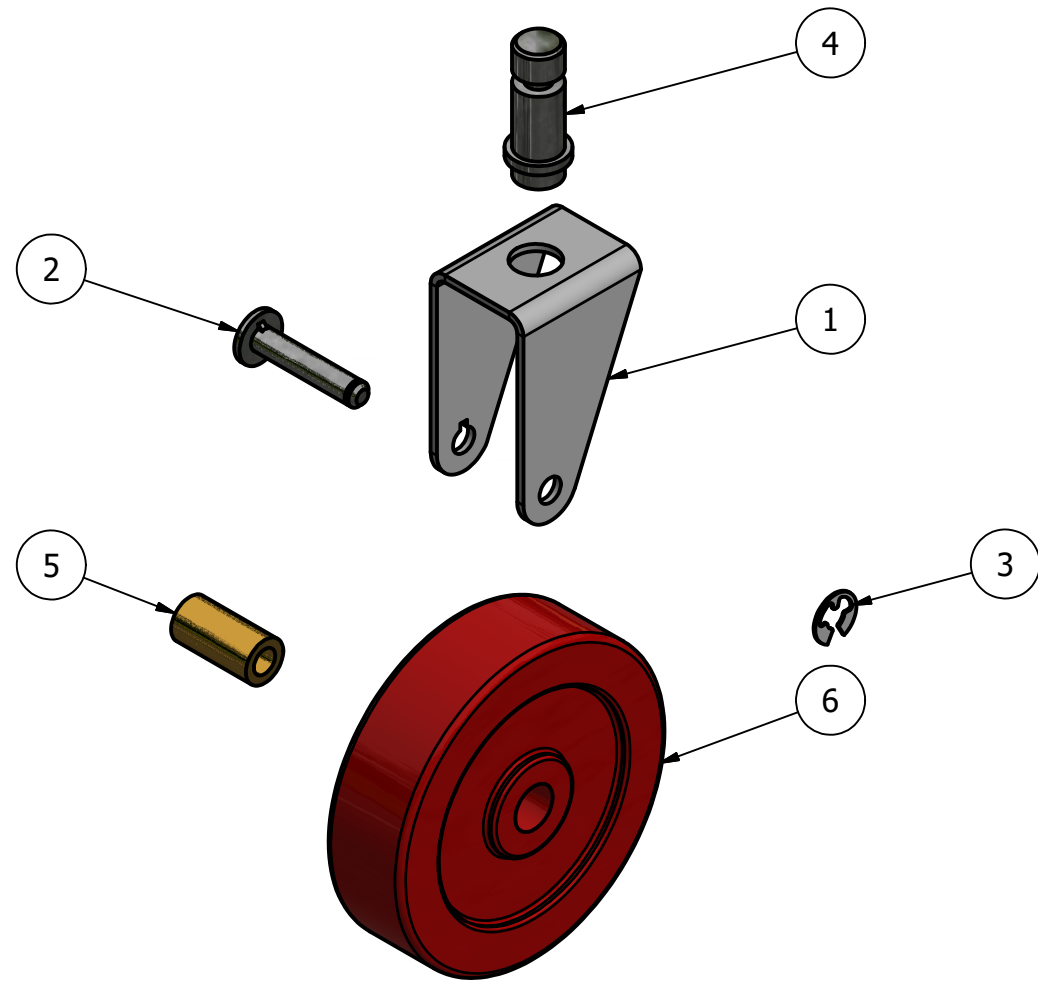

CASTER EXPLODED ASSEMBLY
SCALE 1 / 2

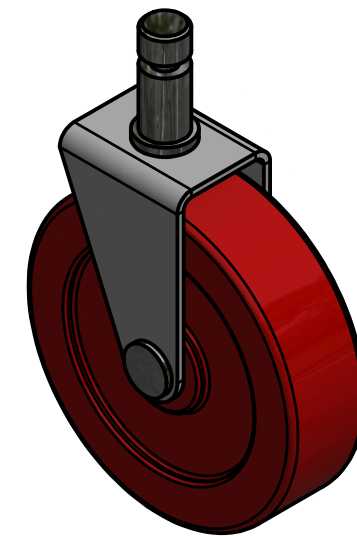

CASTER ASSEMBLY
SCALE 1 / 2

LEGEND:

- ∅ DIAMETER
- R RADIUS
- ° DEGREES

METRIC



DIGITAL DESIGN
GRAPHICS
TECHNOLOGY

WWW.DDGT.NET

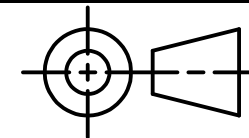

TOLERANCES UNLESS SPECIFIED:
MILLIMETERS:
WHOLE NUMBER = ±.5
X = ±.25
XX = ±.125

ANGLES ±1 DEGREE

SURFACES $\sqrt{32}$

COURSE: DDGT 120

INVENTOR DRAWING NAME:
CASTER

FIG #: 14-90

DRAFTER: J. BARKER

DATE: 12/2/2019

SCALE: AS NOTED

PAGE #: 1 OF 4

PARTS LIST		
ITEM	QTY	PART NUMBER
1	1	BRACKET

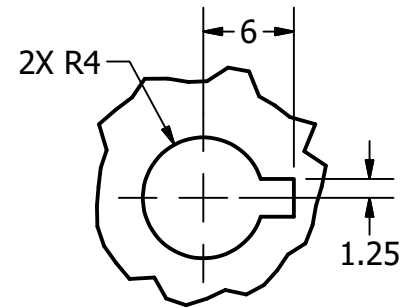
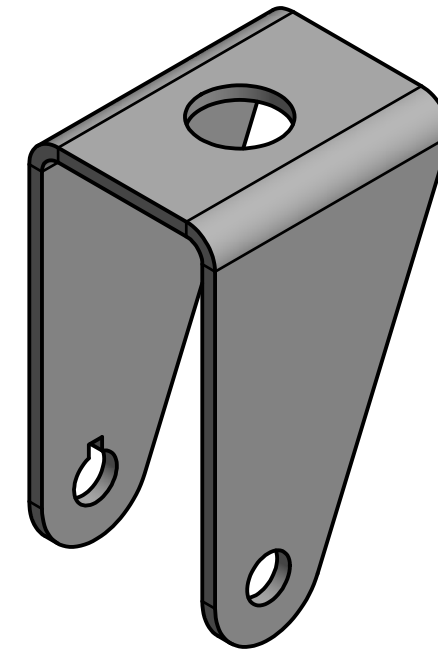

DETAIL A
SCALE 2 : 1

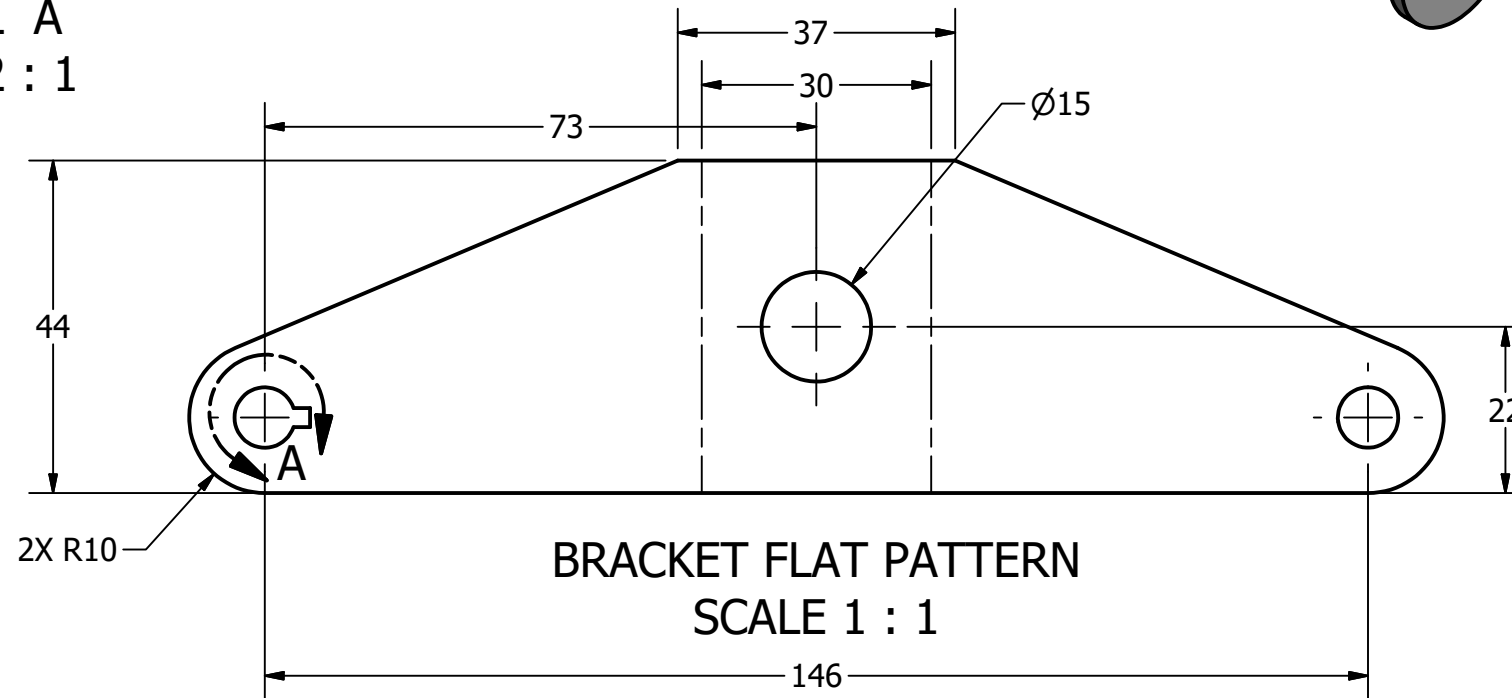

BRACKET FLAT PATTERN
SCALE 1 : 1

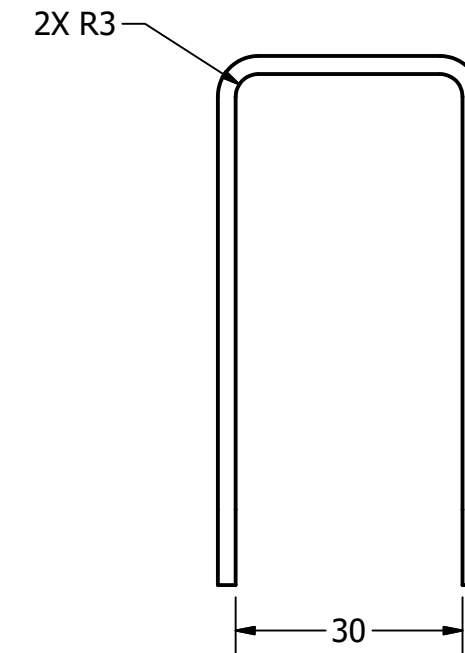

LEGEND:

- Ø DIAMETER
- R RADIUS
- ° DEGREES

METRIC

DDGT

DIGITAL DESIGN
GRAPHICS
TECHNOLOGY

WWW.DDGT.NET

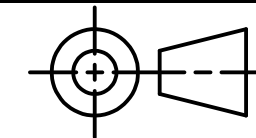

TOLERANCES UNLESS SPECIFIED:
MILLIMETERS:
WHOLE NUMBER = ±.5
X = ±.25
XX = ±.125
ANGLES ±1 DEGREE
SURFACES $\sqrt{32}$

COURSE:	DDGT 120
INVENTOR DRAWING NAME:	CASTER
FIG #:	14-90
DRAFTER:	J. BARKER
DATE:	12/2/2019
SCALE:	AS NOTED
PAGE #:	2 OF 4

PARTS LIST		
ITEM	QTY	PART NUMBER
2	1	SHAFT
4	1	POST

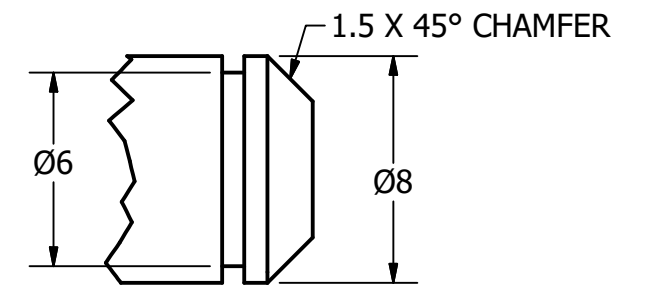
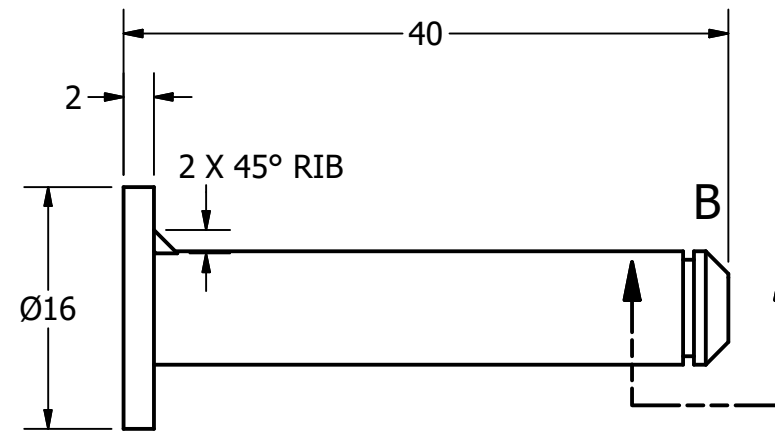
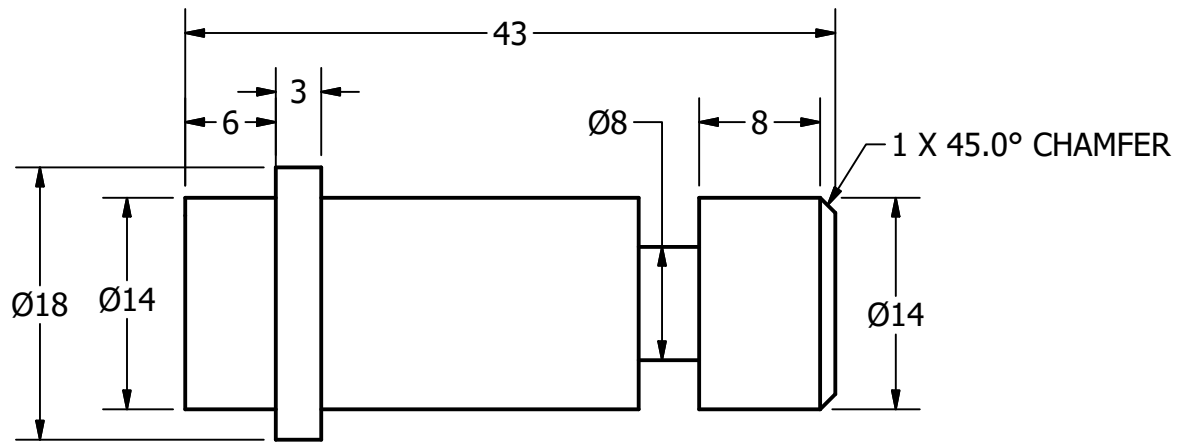
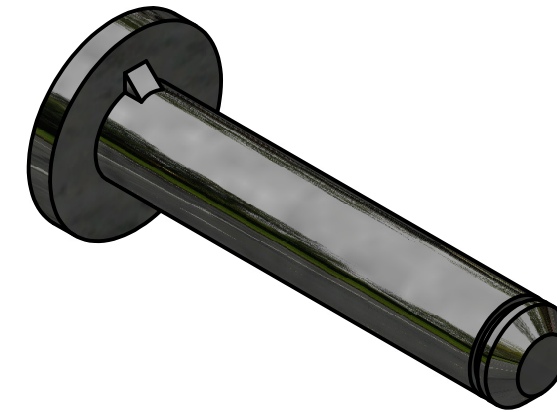
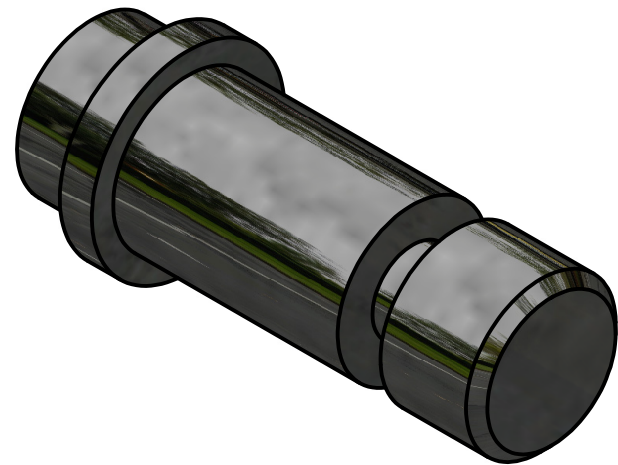

LEGEND:

- Ø DIAMETER
- R RADIUS
- ° DEGREES

METRIC



DIGITAL DESIGN
GRAPHICS
TECHNOLOGY

WWW.DDGT.NET

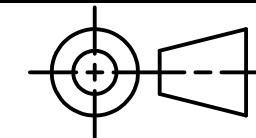

TOLERANCES UNLESS SPECIFIED:
MILLIMETERS:
WHOLE NUMBER = ±.5
X = ±.25
XX = ±.125

ANGLES ±1 DEGREE
SURFACES $\sqrt{32}$

COURSE: DDGT 120

INVENTOR DRAWING NAME:
CASTER

FIG #: 14-90

DRAFTER: J. BARKER

DATE: 12/2/2019

SCALE: AS NOTED

PAGE #: 3 OF 4

PARTS LIST		
ITEM	QTY	PART NUMBER
5	1	BUSHING
6	1	WHEEL

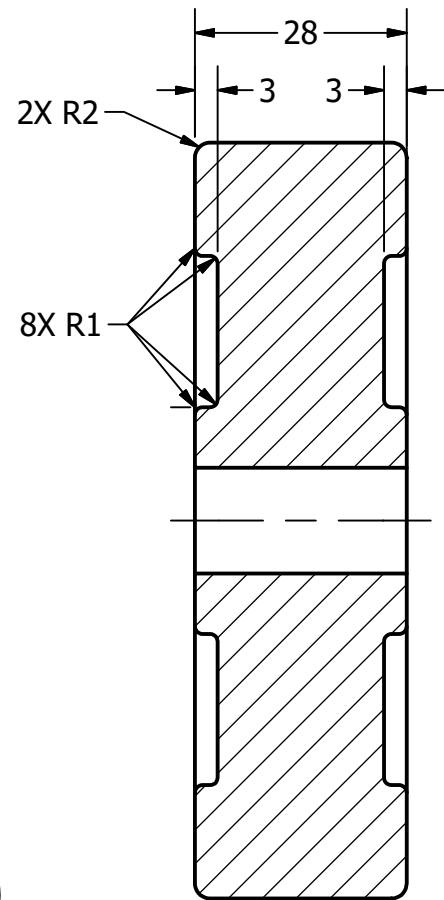
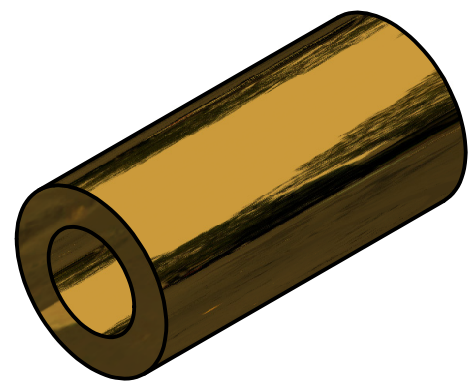

SECTION C-C
SCALE 1 : 1

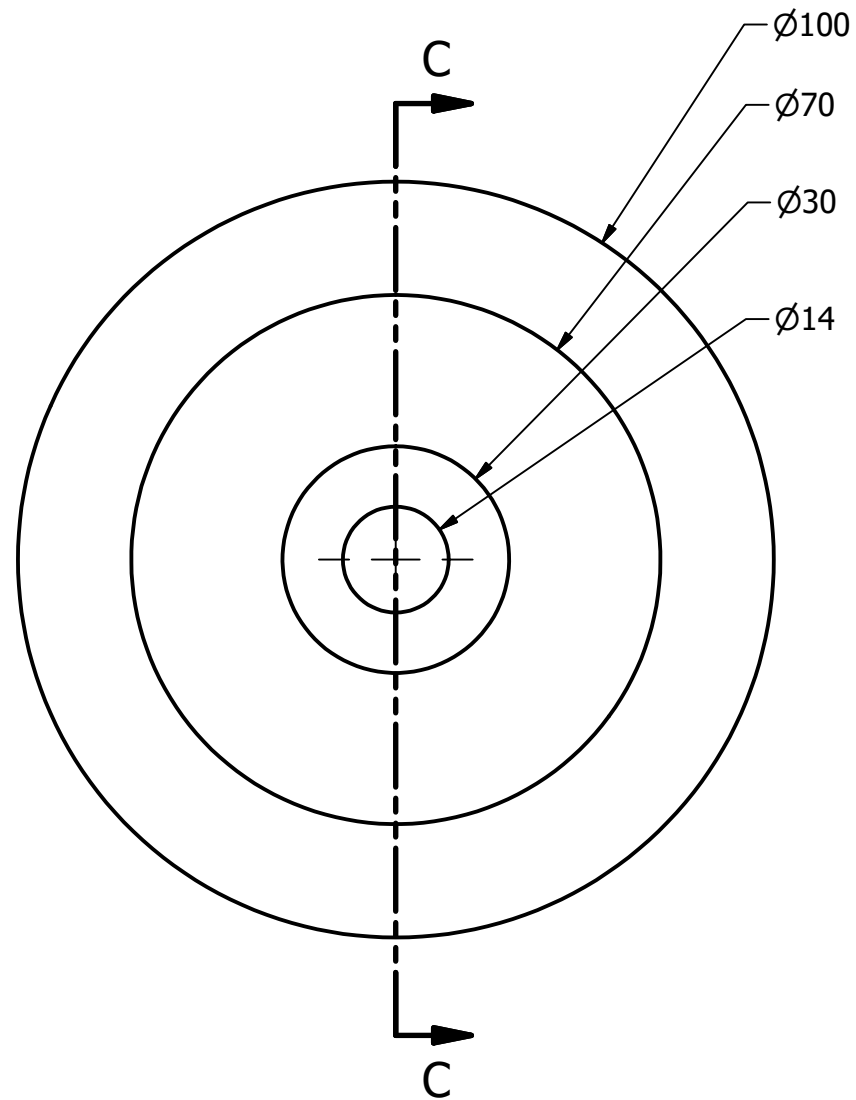

WHEEL
SCALE 1 : 1

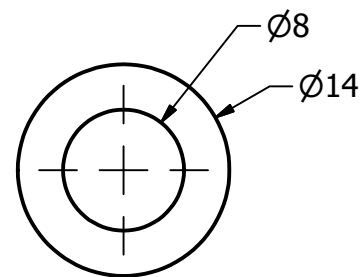
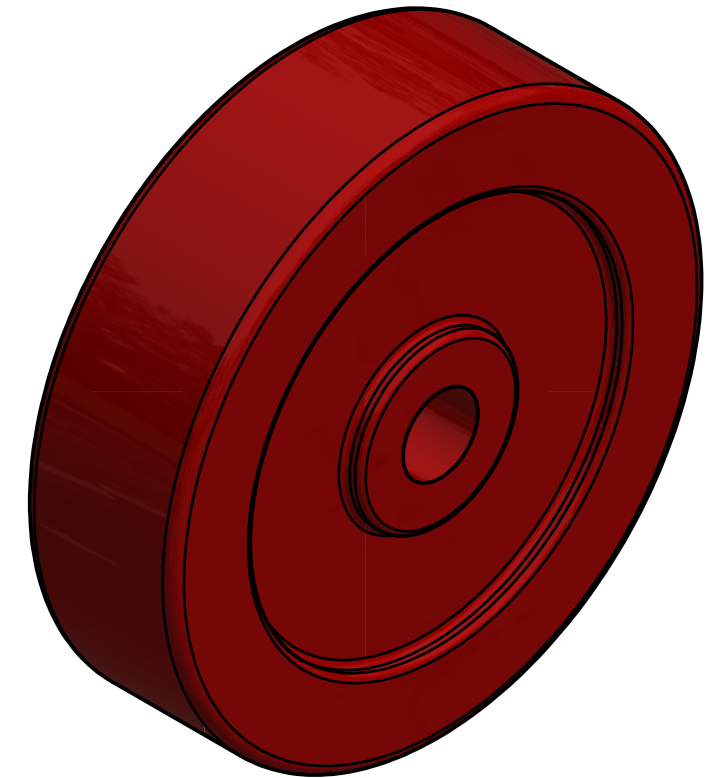

BUSHING
SCALE 2 : 1

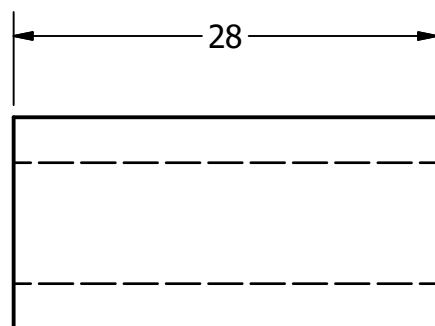

METRIC

LEGEND:

- ∅ DIAMETER
- R RADIUS
- ° DEGREES

DDGT

DIGITAL DESIGN
GRAPHICS
TECHNOLOGY

WWW.DDGT.NET

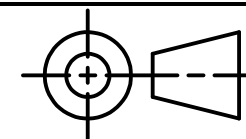

TOLERANCES UNLESS SPECIFIED:
MILLIMETERS:
WHOLE NUMBER = ±.5
X = ±.25
XX = ±.125

ANGLES ±1 DEGREE
SURFACES $\sqrt{32}$

COURSE: DDGT 120

INVENTOR DRAWING NAME:
CASTER

FIG #: 14-90

DRAFTER: J. BARKER

DATE: 12/2/2019

SCALE: AS NOTED

PAGE #: 4 OF 4