

CASTER ASSEMBLY  
SCALE 1:2

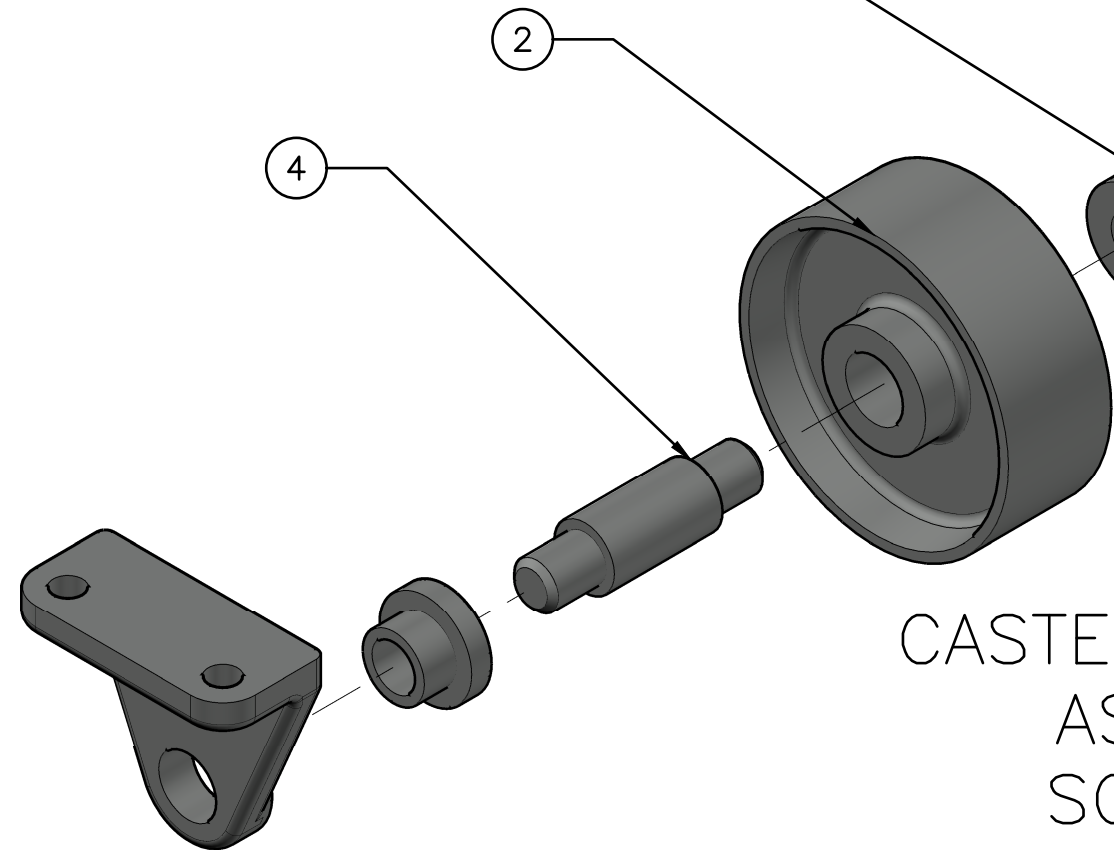
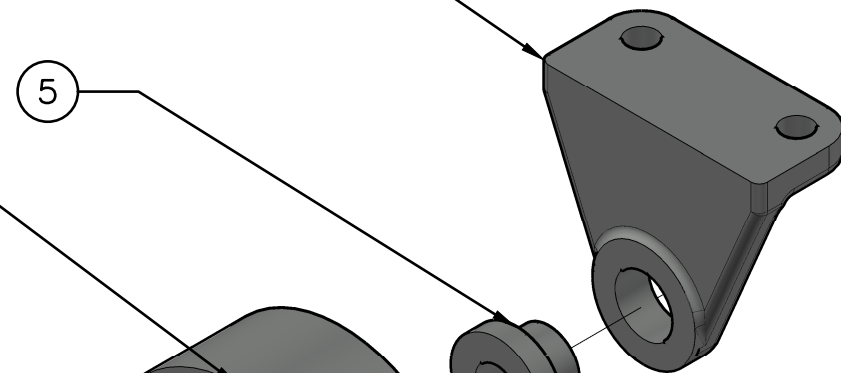
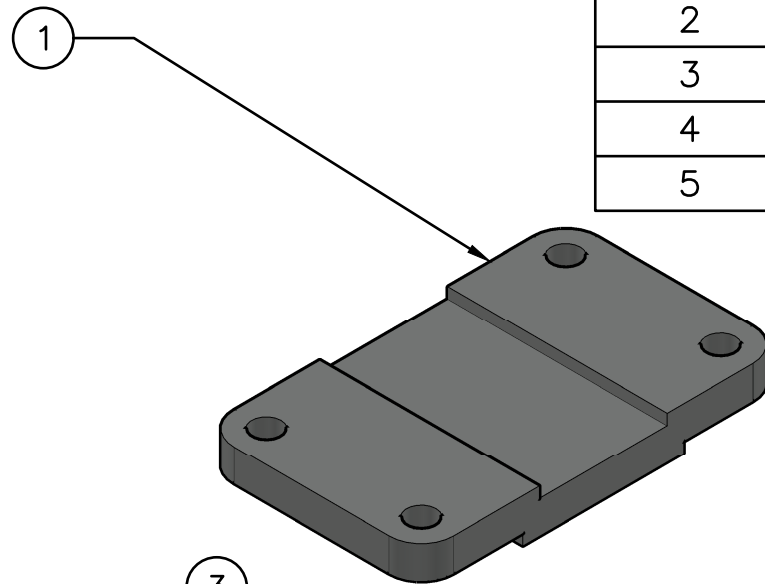

CASTER EXPLODED ASSEMBLY  
SCALE 1:2

## PARTS LIST

ITEM	QTY.	PART NAME	MATERIAL
1	1	TOP PLATE	MALLEABLE IRON
2	1	WHEEL	MALLEABLE IRON
3	2	AXLE SUPPORT	MALLEABLE IRON
4	1	AXLE	SAE 1020
5	2	BUSHING	BRONZE

## GENERAL NOTES:

FASTEN ASSEMBLY TO A 6mm STEEL PLATE BY FOUR M10 X 40mm LONG HEX HEAD BOLTS, NUTS, AND LOCK WASHERS

ROUNDS AND FILLETS R3

FIT	BETWEEN PARTS
H8/f8	4 AND 5
H7/p7	3 AND 5
H8/f7	2 AND 4

METRIC

## LEGEND:

- ∅ DIAMETER
- R RADIUS
- ° DEGREES
- | SPOTFACE/COUNTERBORE

# DDGT

DIGITAL DESIGN  
GRAPHICS  
TECHNOLOGY

WWW.DDGT.NET



DeGraws' Digital Design  
Jacob DeGraw  
Phone: (707) 312-0922  
jacobdegrow707@gmail.com  
http://ddgt.net/StudentPages/jdegrow

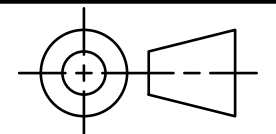

TOLERANCES UNLESS SPECIFIED:  
MILLIMETERS:  
WHOLE NUMBERS = ±.5  
X = ±.25  
XX = ±.12  
FRACTIONAL ±1/64"  
ANGLES ±1 DEGREE  
SURFACES 32/

CLASS: DDGT120

ASSIGNMENT #: 60

AUTOCAD DRAWING NAME:

CASTER

FIG #: 9-51

MANAGER: G. STROMMEN

DRAFTER: J. DEGRAW

DATE: 4/4/2023

SCALE: AS NOTED

PAGE #: 1 OF 3

# GENERAL NOTES:

FASTEN ASSEMBLY TO A 6mm STEEL PLATE BY FOUR M10 X 40mm LONG HEX HEAD BOLTS, NUTS, AND LOCK WASHERS

ROUNDS AND FILLETS R3

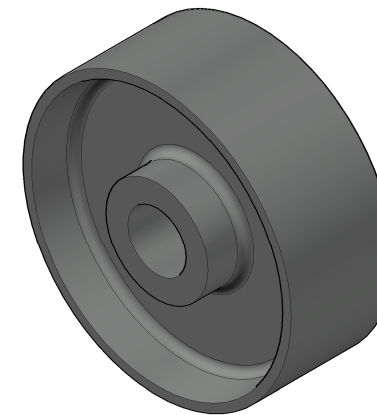
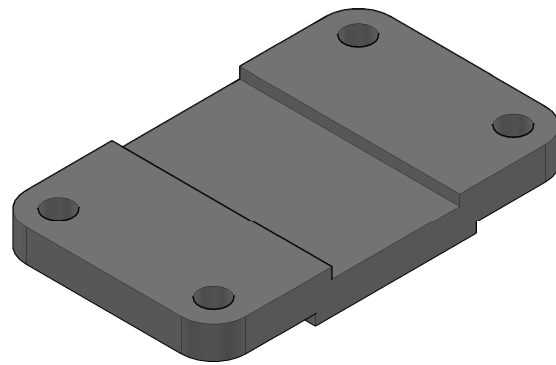

PARTS LIST		
ITEM	QTY.	PART NAME
1	1	TOP PLATE
2	1	WHEEL

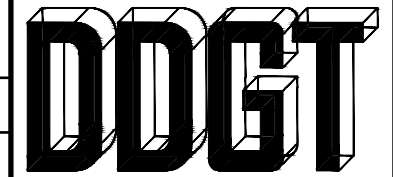

DIGITAL DESIGN  
GRAPHICS  
TECHNOLOGY

WWW.DDGT.NET

DeGraws' Digital Design  
Jacob DeGraw  
Phone: (707) 312-0922  
jacobdegrow707@gmail.com  
http://ddgt.net/StudentPages/jdegrow

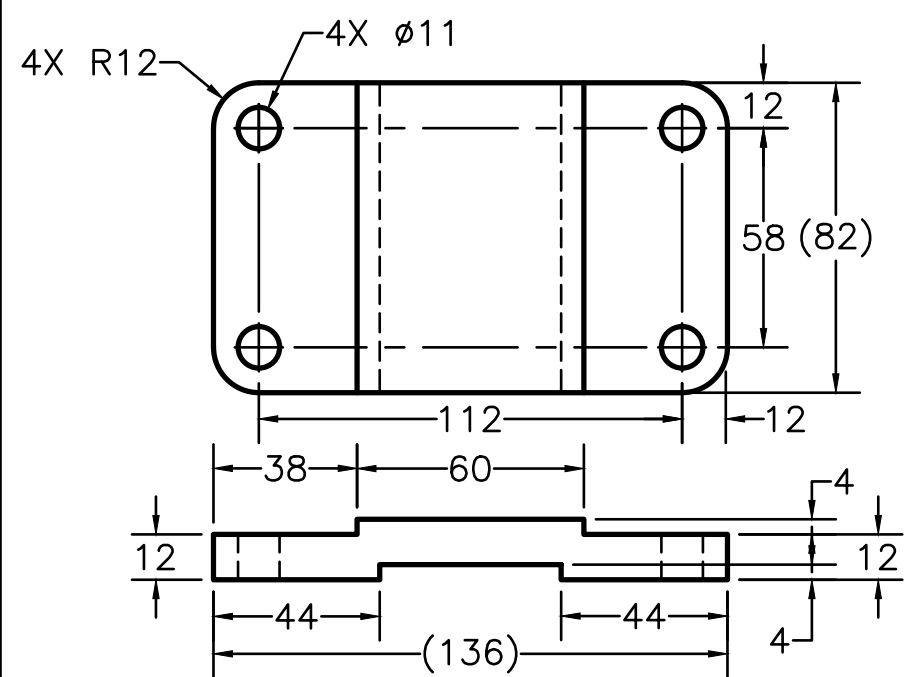

TOP PLATE  
SCALE 1:2

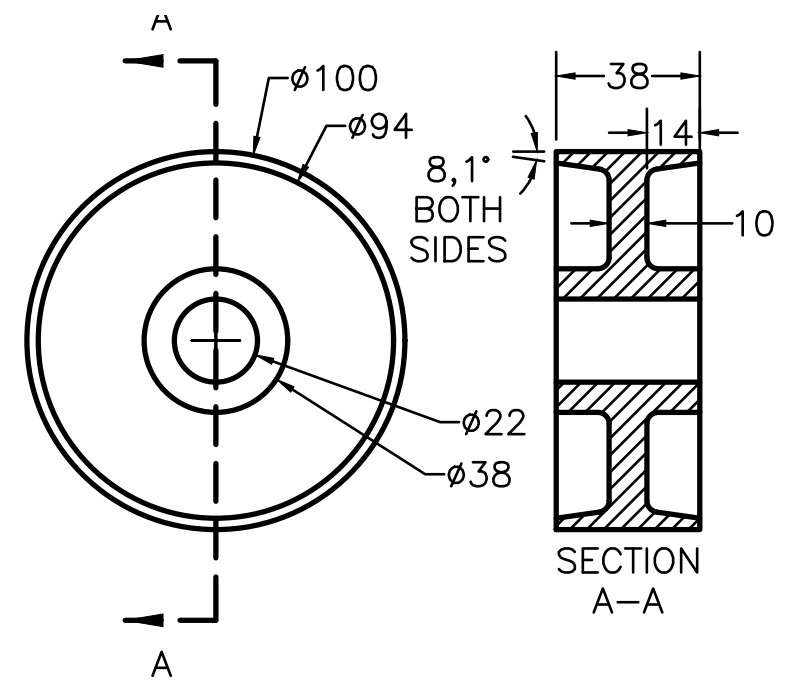

WHEEL  
SCALE 1:2

METRIC

## LEGEND:

- Ø DIAMETER
- R RADIUS
- ° DEGREES
- | SPOTFACE/COUNTERBORE

TOLERANCES UNLESS SPECIFIED:  
MILLIMETERS:  
WHOLE NUMBERS = ±.5  
X = ±.25  
XX = ±.12  
FRACTIONAL ±1/64"  
ANGLES ±1 DEGREE  
SURFACES 32/

CLASS:	DDGT120
ASSIGNMENT #:	60
AUTOCAD DRAWING NAME:	CASTER
FIG #:	9-51
MANAGER:	G. STROMMEN
DRAFTER:	J. DEGRAW
DATE:	4/4/2023
SCALE:	AS NOTED
PAGE #:	2 OF 3

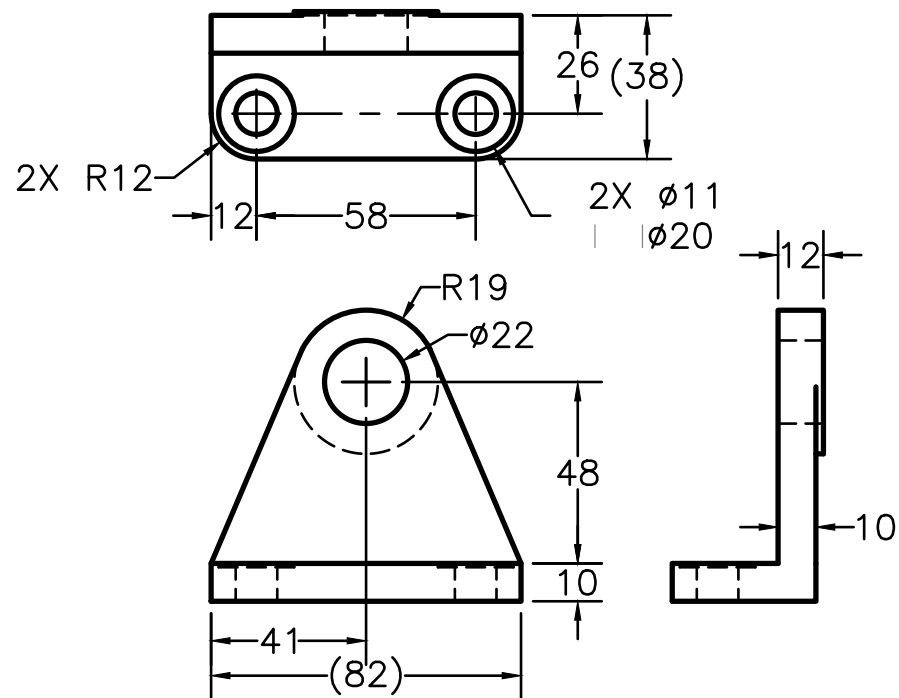
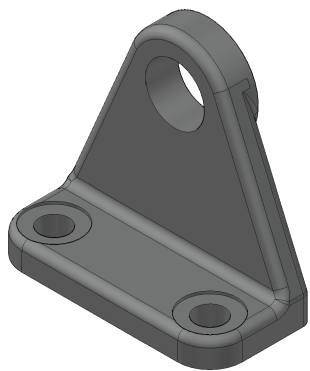

AXLE SUPPORT  
SCALE 1:2

GENERAL NOTES:

FASTEN ASSEMBLY TO A 6mm STEEL  
PLATE BY FOUR M10 X 40mm LONG HEX  
HEAD BOLTS, NUTS, AND LOCK WASHERS

ROUNDS AND FILLETS R3

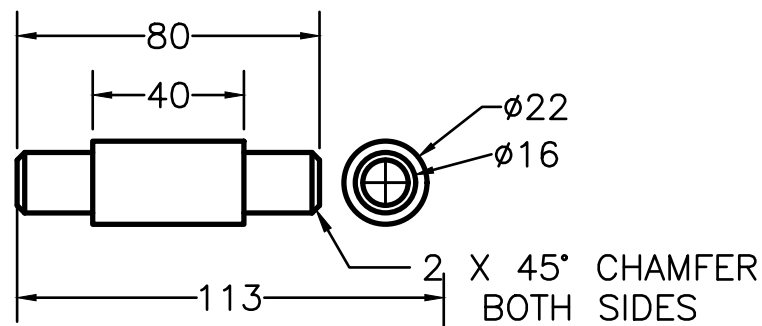

AXLE  
SCALE 1:2

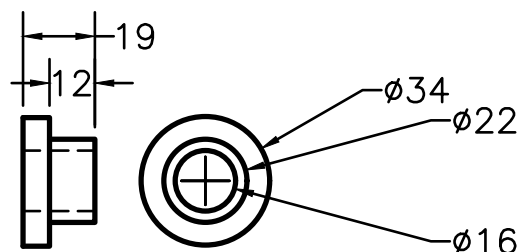
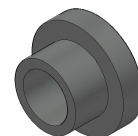

BUSHING  
SCALE 1:2

PARTS LIST

ITEM	QTY.	PART NAME
3	2	AXLE SUPPORT
4	1	AXLE
5	2	BUSHING

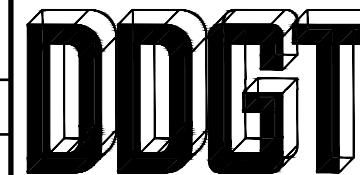

DIGITAL DESIGN  
GRAPHICS  
TECHNOLOGY

WWW.DDGT.NET

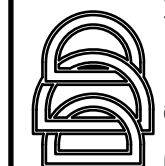

DeGraws' Digital Design  
Jacob DeGraw  
Phone: (707) 312-0922  
jacobdegraw707@gmail.com  
http://ddgt.net/StudentPages/jdegraw

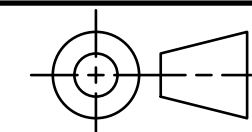

METRIC

TOLERANCES UNLESS SPECIFIED:  
MILLIMETERS:  
WHOLE NUMBERS =  $\pm 0.5$   
X =  $\pm 0.25$   
XX =  $\pm 0.12$   
FRACTIONAL  $\pm 1/64$ "  
ANGLES  $\pm 1$  DEGREE  
SURFACES  $32/$

CLASS: DDGT120

ASSIGNMENT #: 60

AUTOCAD DRAWING NAME:  
CASTER

FIG #: 9-51

MANAGER: G. STROMMEN

DRAFTER: J. DEGRAW

DATE: 4/4/2023

SCALE: AS NOTED

PAGE #: 3 OF 3

LEGEND:

- $\phi$  DIAMETER
- R RADIUS
- ° DEGREES
- | | SPOTFACE/COUNTERBORE