

GENERAL NOTES:

TROLLEY TO BE MOUNTED ON AN S200 X 34 BEAM

ALL CHAMFERS ARE 2 X 2 UNLESS OTHERWISE NOTES

PARTS LIST				
ITEM	QTY	PART NUMBER	MATERIAL	DESCRIPTION
1	2	SIDE PLATE SUB-ASSEMBLY		
1.1	1	SIDE PLATE	MILD STEEL	
1.2	1	GUIDE	CAST IRON	
1.3	2	RIVET	STANDARD	BUTTON HEAD, Ø 10 X 60 LONG
2	1	AXLE	COLD ROLLED STEEL	
3	1	HOOK	MILD STEEL	10 THICK
4	44	ROLLER BEARING	COLD ROLLED STEEL	Ø10 X 38 LONG
5	4	WHEEL	CAST IRON	
6	4	WHEEL AXLE	COLD ROLLED STEEL	
7	12	ADJUSTING WASHER	STANDARD	Ø26ID X Ø44OD X 4 THICK
8	4	WASHER	STANDARD	Ø 26ID X Ø65OD X 3 THICK
9	4	LOCKNUT	STANDARD	M16 x 2 (PREVAILING TORQUE INSERT-TYPE)
10	6	COTTER PIN	STANDARD	Ø6 X 40 LONG

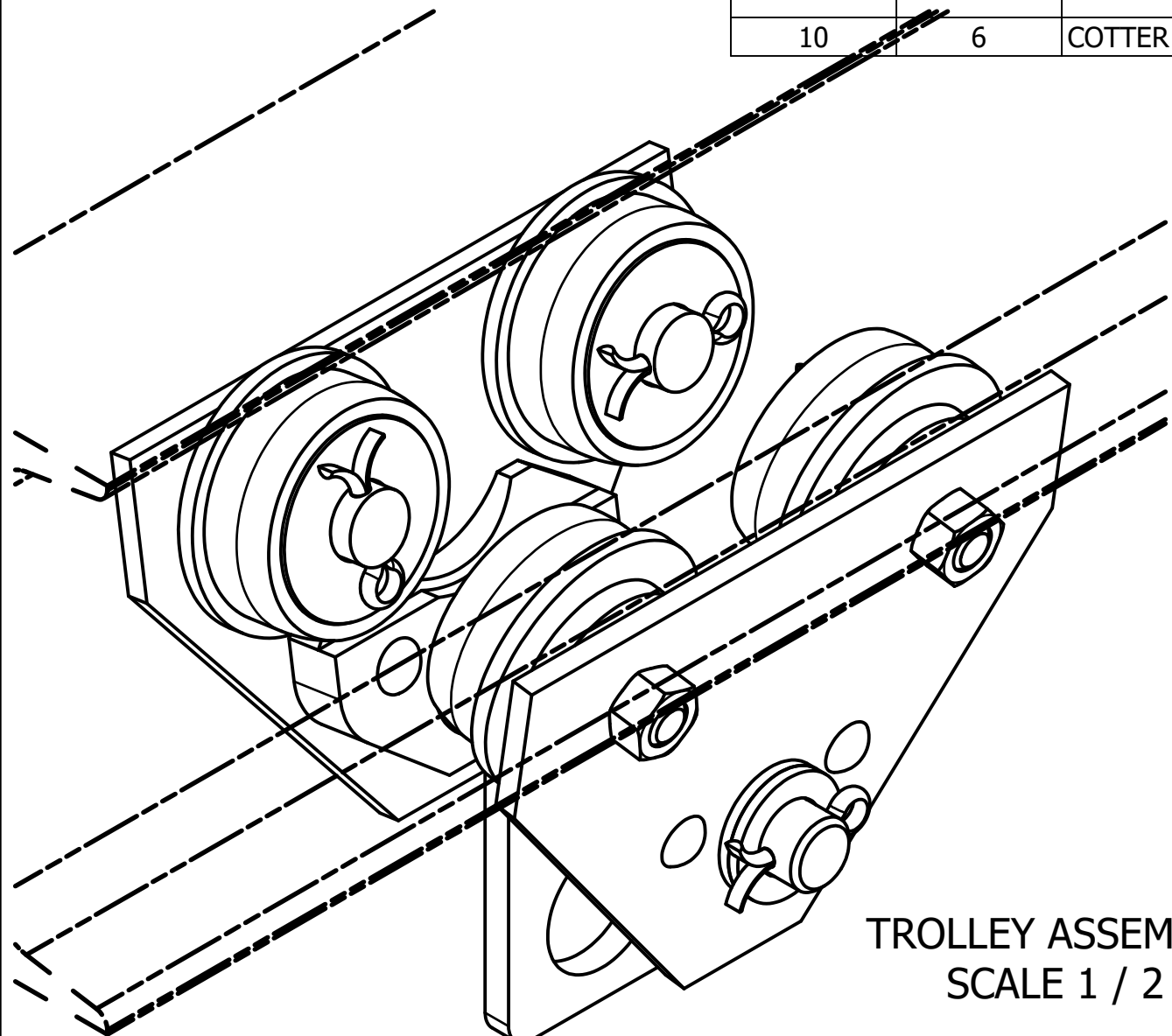

TROLLEY ASSEMBLY
SCALE 1 / 2

METRIC

LEGEND:

- Ø DIAMETER
- R RADIUS
- DEGREES



DIGITAL DESIGN
GRAPHICS
TECHNOLOGY

WWW.DDGT.NET

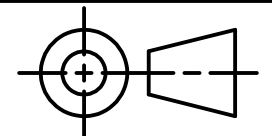

TOLERANCES UNLESS SPECIFIED:
MILLIMETERS:
WHOLE NUMBERS = ±.5
X = ±.25
XX = ±.12
FRACTIONAL ±1/64"
ANGLES ±1 DEGREE
SURFACES ³² ✓

CLASS: DDGT 120

ASSIGNMENT #: 70

INVENTOR DRAWING NAME:
TROLLEY

FIG #: 14-83

MANAGER: G. STROMMEN

DRAFTER: J. DEGRAW

DATE: 11/29/2022

SCALE: AS NOTED

PAGE #: 1 OF 6

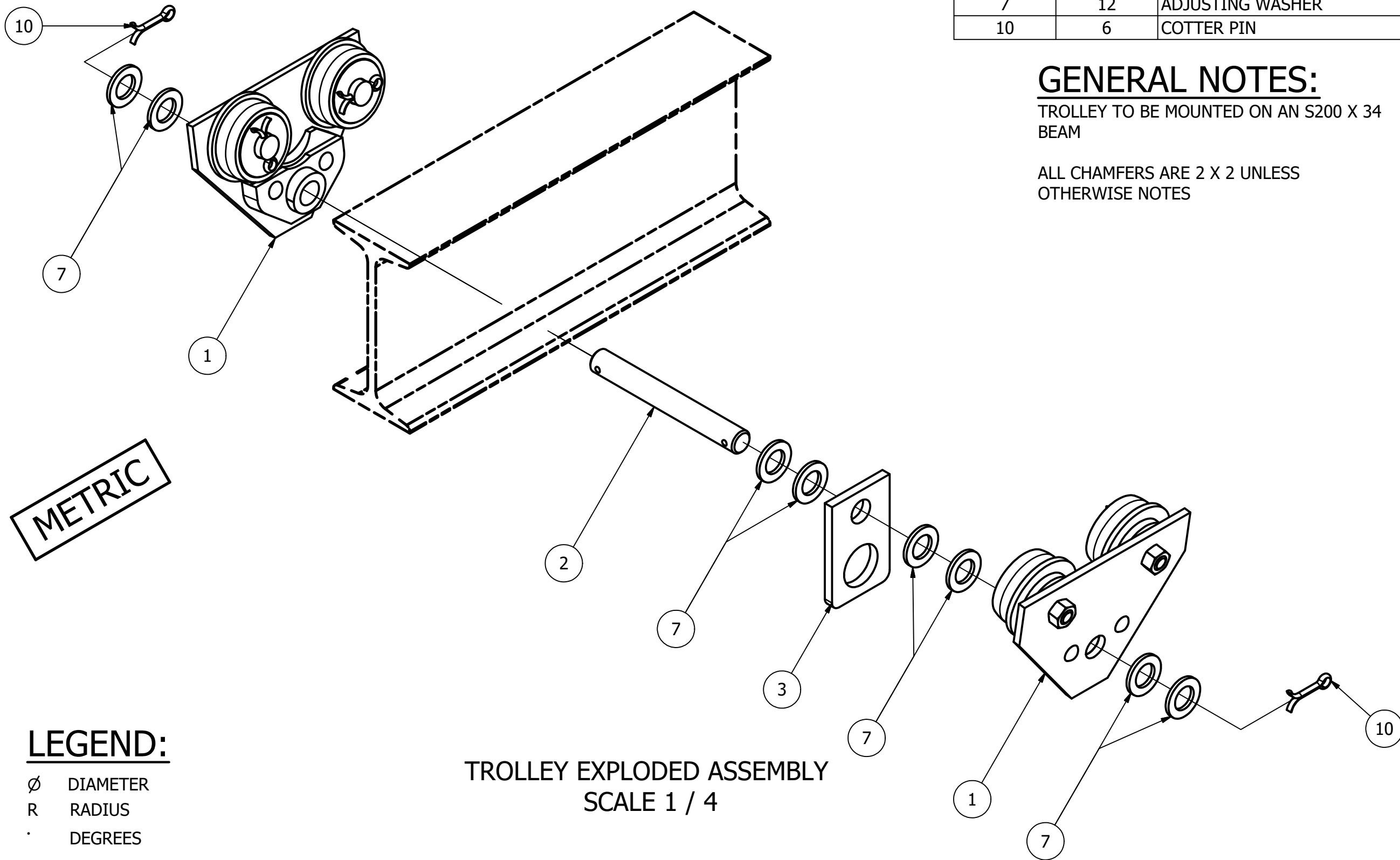

PARTS LIST		
ITEM	QTY	PART NUMBER
1	2	SIDE PLATE SUB-ASSEMBLY
2	1	AXLE
3	1	HOOK
7	12	ADJUSTING WASHER
10	6	COTTER PIN

GENERAL NOTES:
 TROLLEY TO BE MOUNTED ON AN S200 X 34 BEAM
 ALL CHAMFERS ARE 2 X 2 UNLESS OTHERWISE NOTES



DIGITAL DESIGN
 GRAPHICS
 TECHNOLOGY

WWW.DDGT.NET

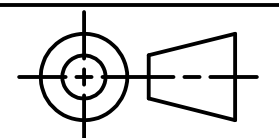

TOLERANCES UNLESS SPECIFIED:
 MILLIMETERS:
 WHOLE NUMBERS = ±.5
 X = ±.25
 XX = ±.12
 FRACTIONAL ±1/64"
 ANGLES ±1 DEGREE
 SURFACES ³²✓

CLASS: DDGT 120

ASSIGNMENT #: 70

INVENTOR DRAWING NAME:
 TROLLEY

FIG #: 14-83

MANAGER: G. STROMMEN

DRAFTER: J. DEGRAW

DATE: 11/29/2022

SCALE: AS NOTED

PAGE #: 2 OF 6

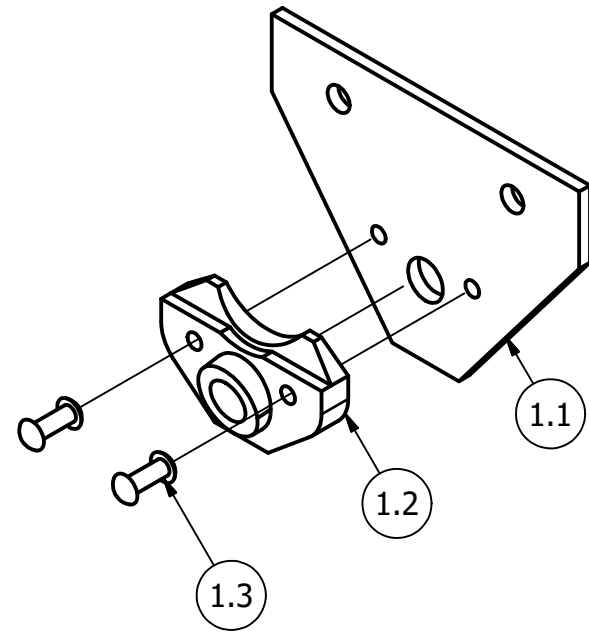

SIDE PLATE SUB- ASSEMBLY
SCALE 1 / 4

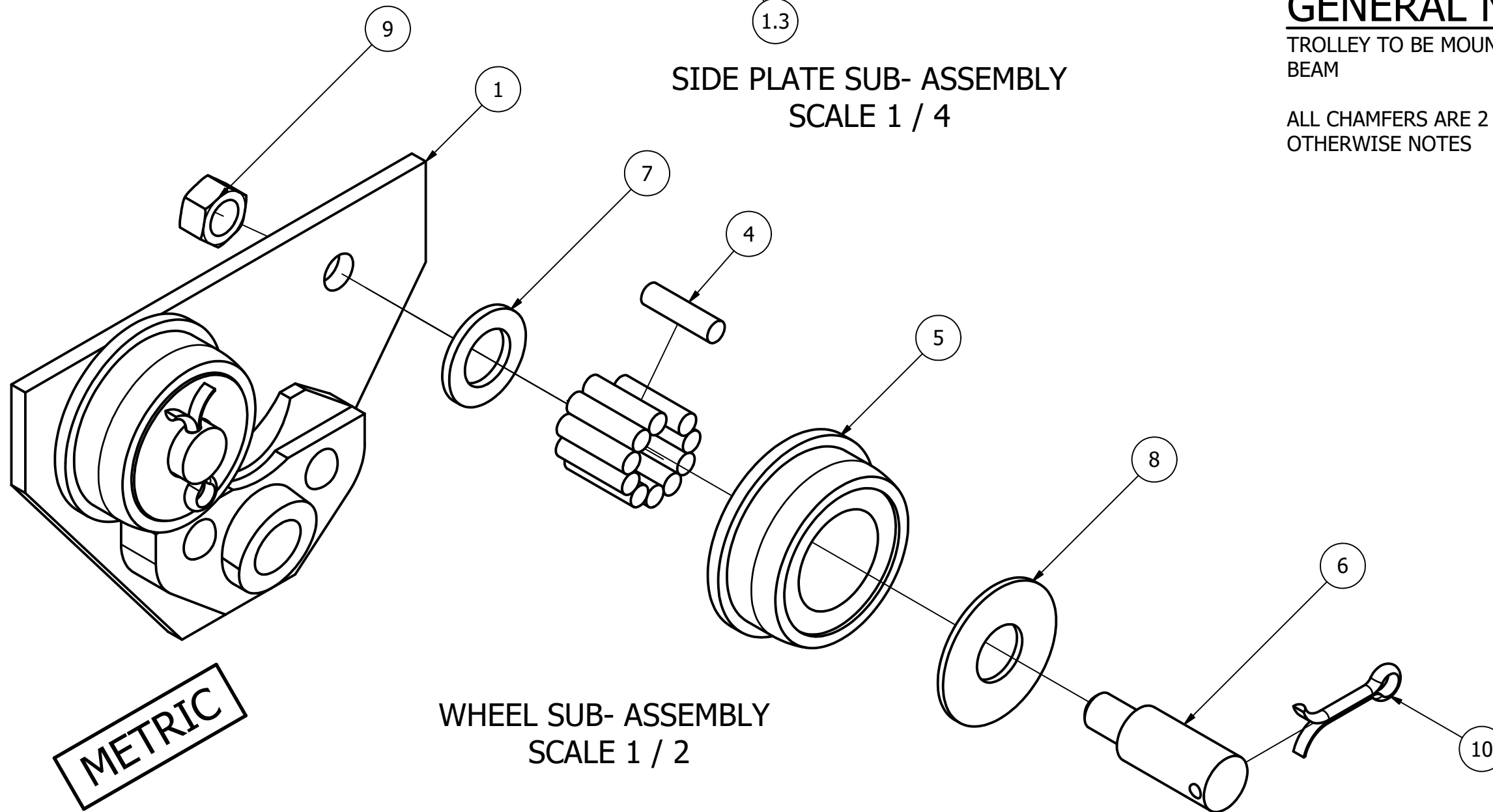

WHEEL SUB- ASSEMBLY
SCALE 1 / 2

PARTS LIST

ITEM	QTY	PART NUMBER
1	2	SIDE PLATE SUB-ASSEMBLY
1.1	1	SIDE PLATE
1.2	1	GUIDE
1.3	2	RIVET
4	44	ROLLER BEARING
5	4	WHEEL
6	4	WHEEL AXLE
7	12	ADJUSTING WASHER
8	4	WASHER
9	4	LOCKNUT
10	6	COTTER PIN

GENERAL NOTES:

TROLLEY TO BE MOUNTED ON AN S200 X 34 BEAM

ALL CHAMFERS ARE 2 X 2 UNLESS OTHERWISE NOTES

LEGEND:

- ∅ DIAMETER
- R RADIUS
- ° DEGREES



DIGITAL DESIGN
GRAPHICS
TECHNOLOGY

WWW.DDGT.NET

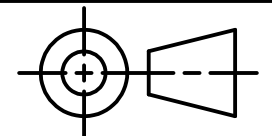

TOLERANCES UNLESS SPECIFIED:
MILLIMETERS:
WHOLE NUMBERS =±.5
X =±.25
XX =±.12
FRACTIONAL ±1/64"
ANGLES ±1 DEGREE
SURFACES ³²✓

CLASS: DDGT 120

ASSIGNMENT #: 70

INVENTOR DRAWING NAME:
TROLLEY

FIG #: 14-83

MANAGER: G. STROMMEN

DRAFTER: J. DEGRAW

DATE: 11/29/2022

SCALE: AS NOTED

PAGE #: 3 OF 6

GENERAL NOTES:

TROLLEY TO BE MOUNTED ON AN S200 X 34 BEAM

ALL CHAMFERS ARE 2 X 2 UNLESS OTHERWISE NOTES

PARTS LIST

ITEM	QTY	PART NUMBER
1.1	2	SIDE PLATE



DIGITAL DESIGN
GRAPHICS
TECHNOLOGY

WWW.DDGT.NET

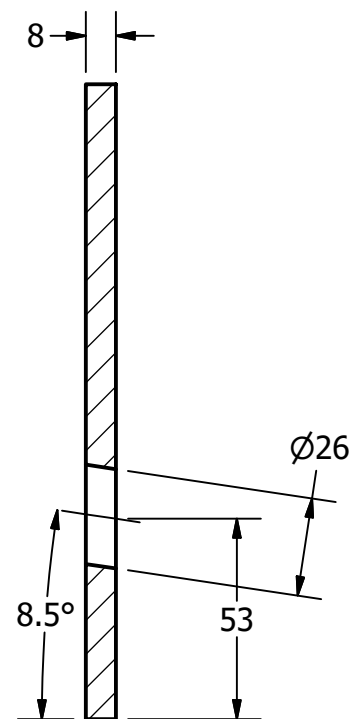
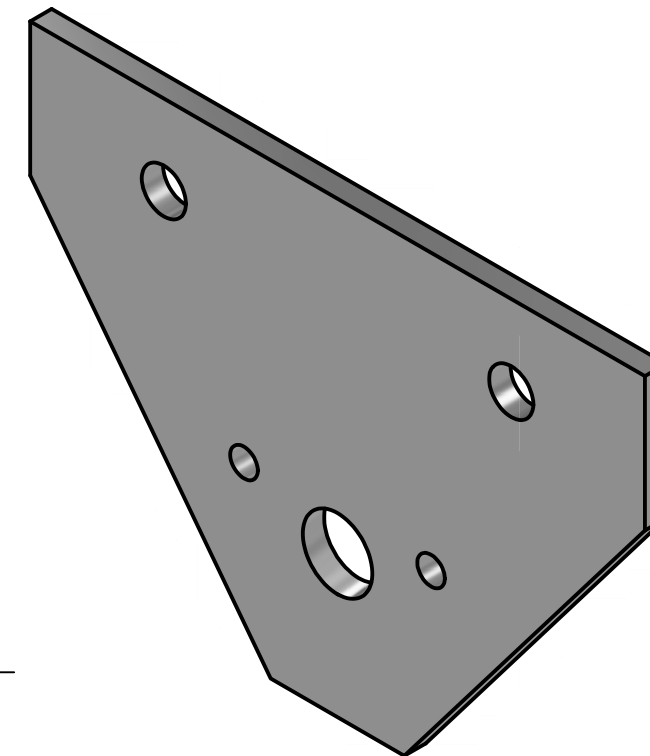

SECTION A-A
SCALE 1 / 2

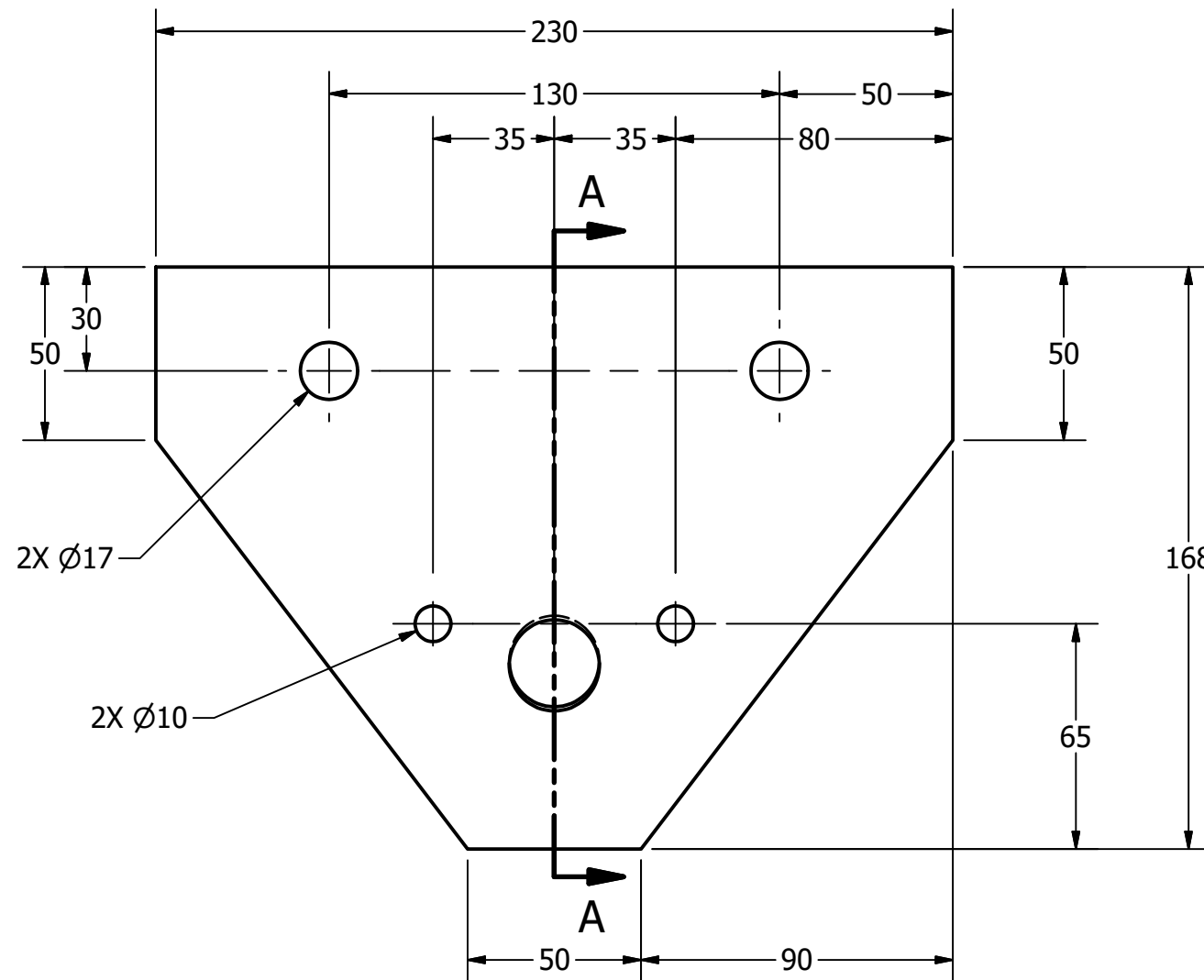

SIDE PLATE
SCALE 1 / 2

METRIC

LEGEND:

- Ø DIAMETER
- R RADIUS
- ° DEGREES

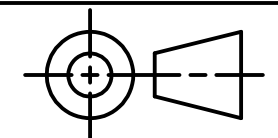

TOLERANCES UNLESS SPECIFIED:
MILLIMETERS:
WHOLE NUMBERS = ±.5
X = ±.25
XX = ±.12
FRACTIONAL ±1/64"
ANGLES ±1 DEGREE
SURFACES 32 ✓

CLASS: DDGT 120

ASSIGNMENT #: 70

INVENTOR DRAWING NAME:
TROLLEY

FIG #: 14-83

MANAGER: G. STROMMEN

DRAFTER: J. DEGRAW

DATE: 11/29/2022

SCALE: AS NOTED

PAGE #: 4 OF 6

PARTS LIST		
ITEM	QTY	PART NUMBER
1.2	2	GUIDE
2	1	AXLE



DIGITAL DESIGN
GRAPHICS
TECHNOLOGY

WWW.DDGT.NET

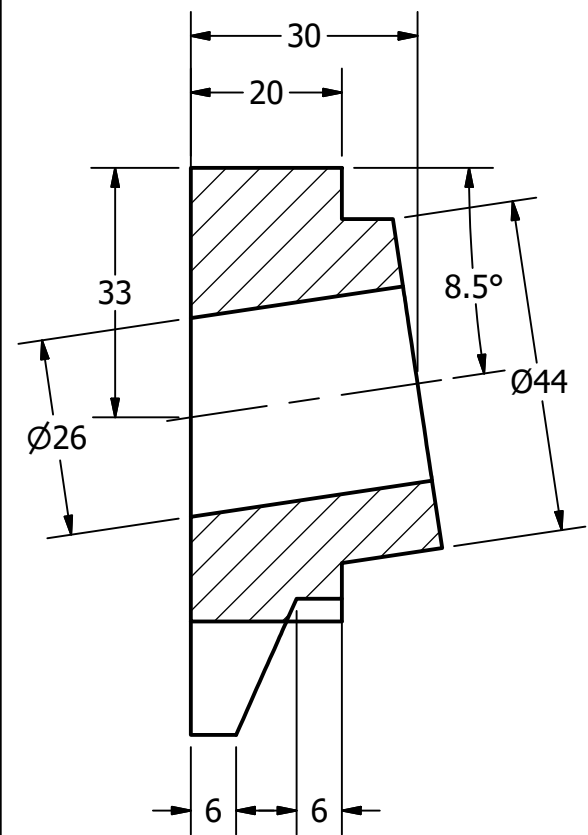

SECTION B-B
SCALE 1 : 1

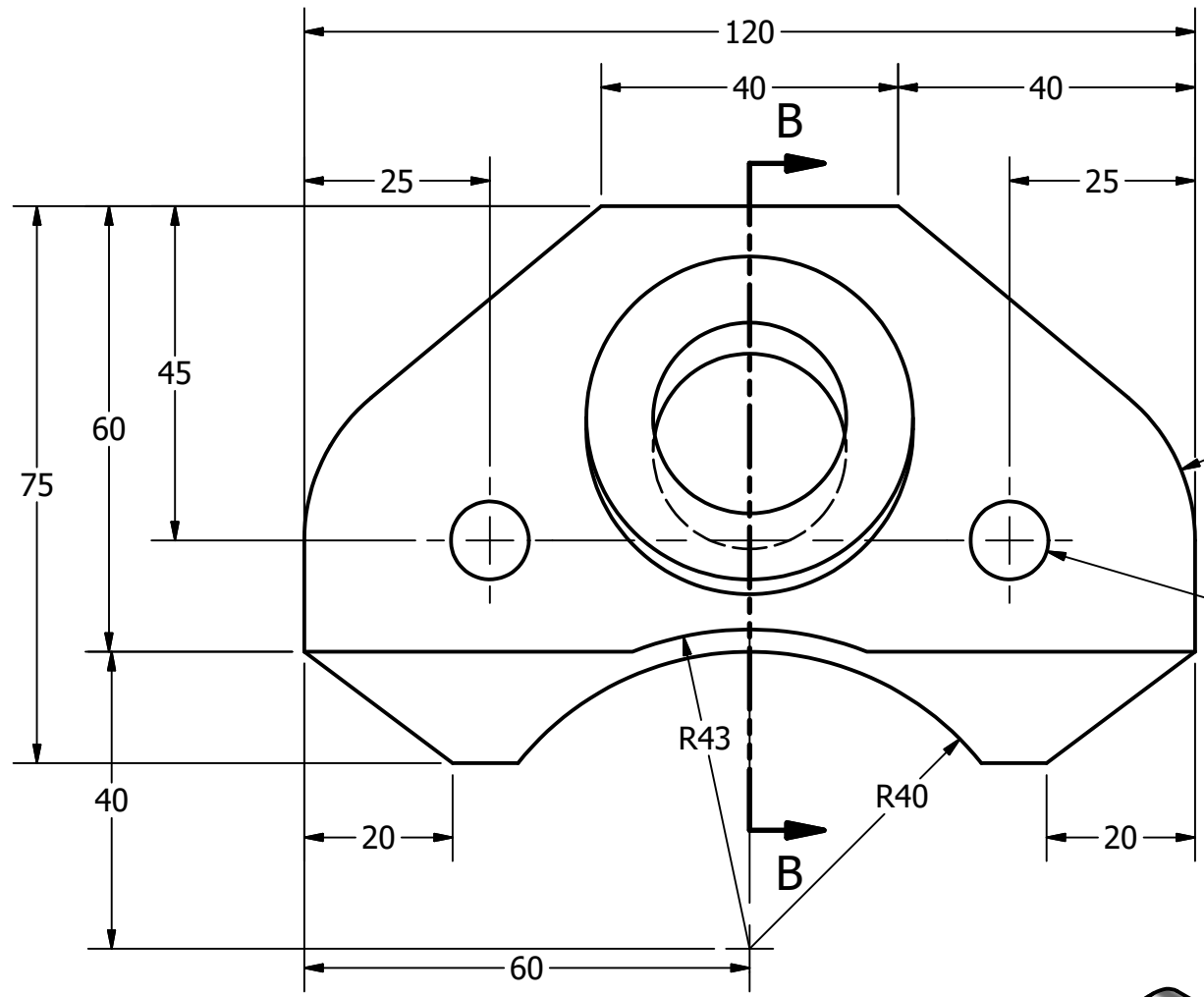

GUIDE
SCALE 1 : 1

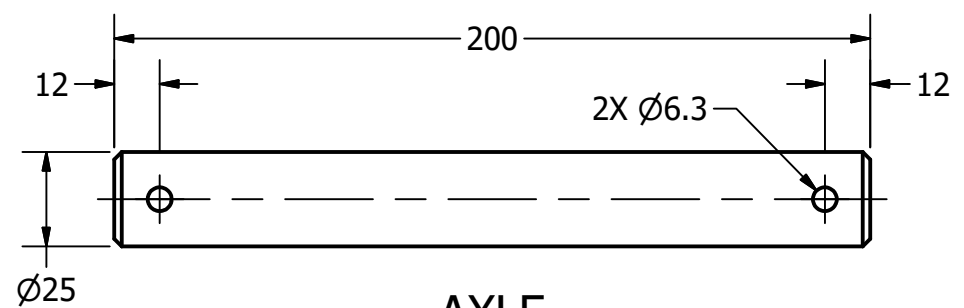
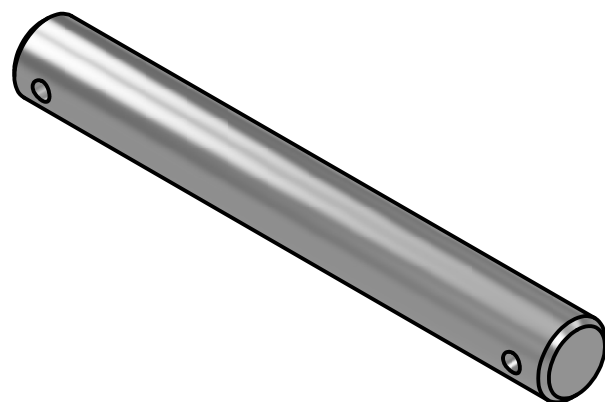
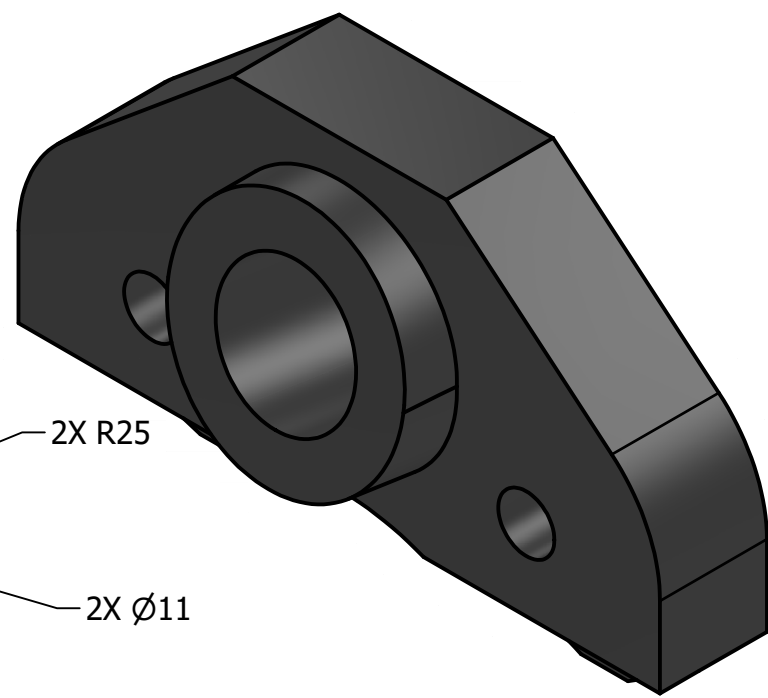

AXLE
SCALE 1 / 2

GENERAL NOTES:

TROLLEY TO BE MOUNTED ON AN S200 X 34 BEAM

ALL CHAMFERS ARE 2 X 2 UNLESS OTHERWISE NOTES

METRIC

LEGEND:

- Ø DIAMETER
- R RADIUS
- DEGREES

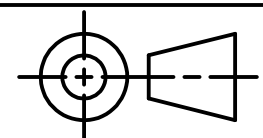

TOLERANCES UNLESS SPECIFIED:
MILLIMETERS:
WHOLE NUMBERS = ±.5
X = ±.25
XX = ±.12
FRACTIONAL ±1/64"
ANGLES ±1 DEGREE
SURFACES 32 ✓

CLASS: DDGT 120

ASSIGNMENT #: 70

INVENTOR DRAWING NAME:
TROLLEY

FIG #: 14-83

MANAGER: G. STROMMEN

DRAFTER: J. DEGRAW

DATE: 11/29/2022

SCALE: AS NOTED

PAGE #: 5 OF 6

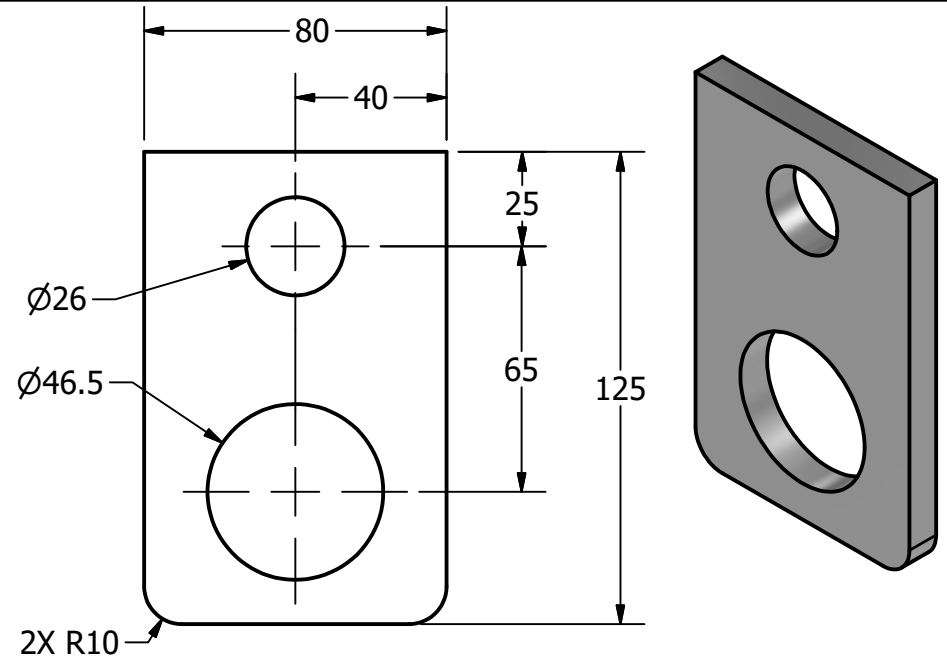

HOOK
SCALE 1 / 2

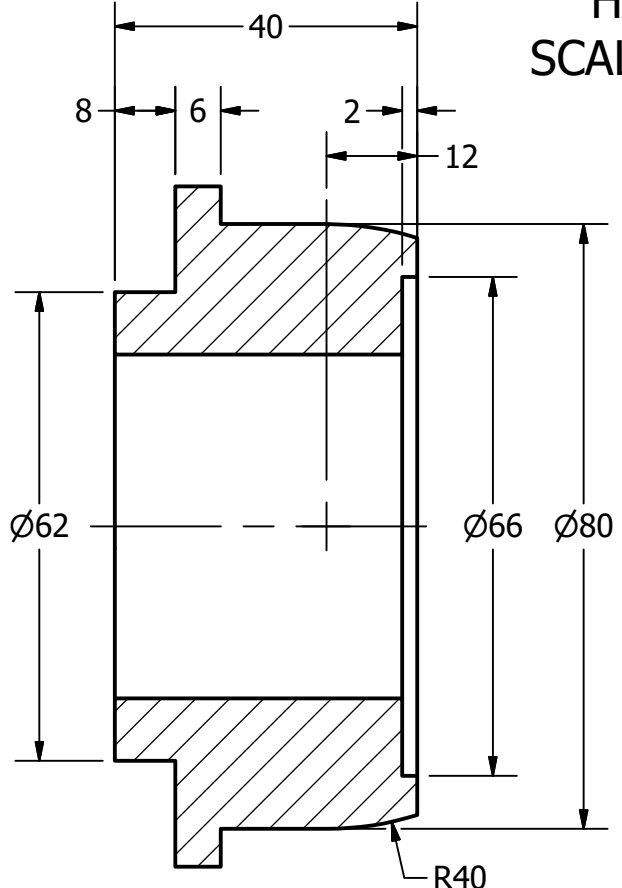

SECTION C-C
SCALE 1 : 1

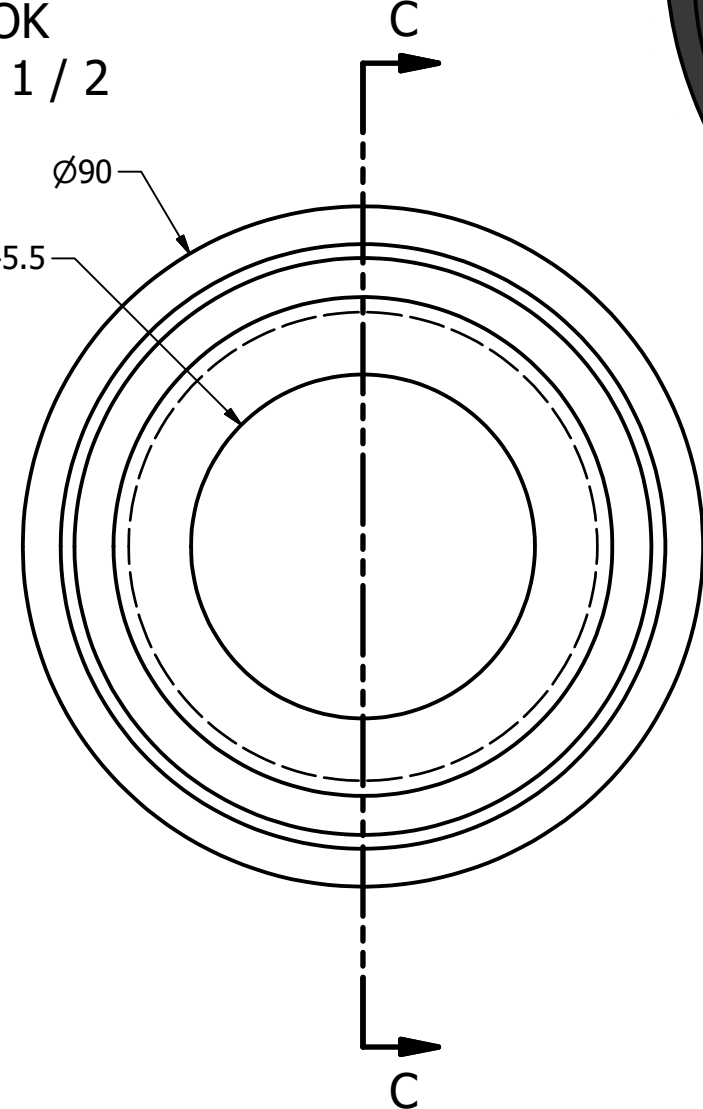

WHEEL
SCALE 1 : 1

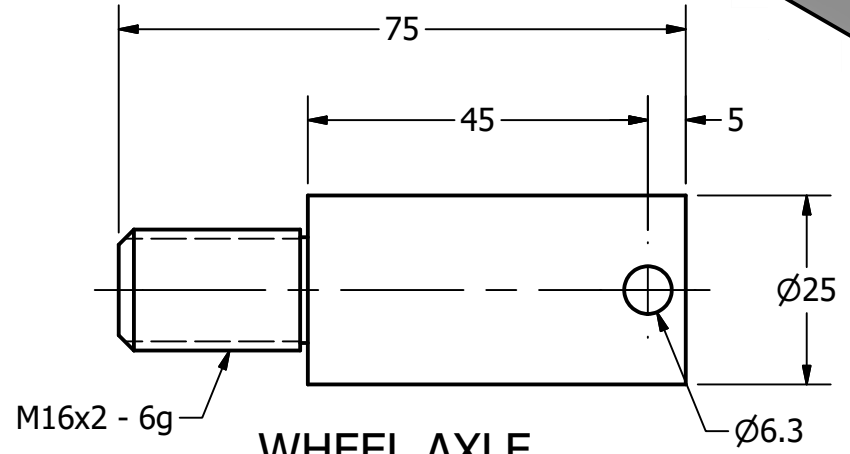
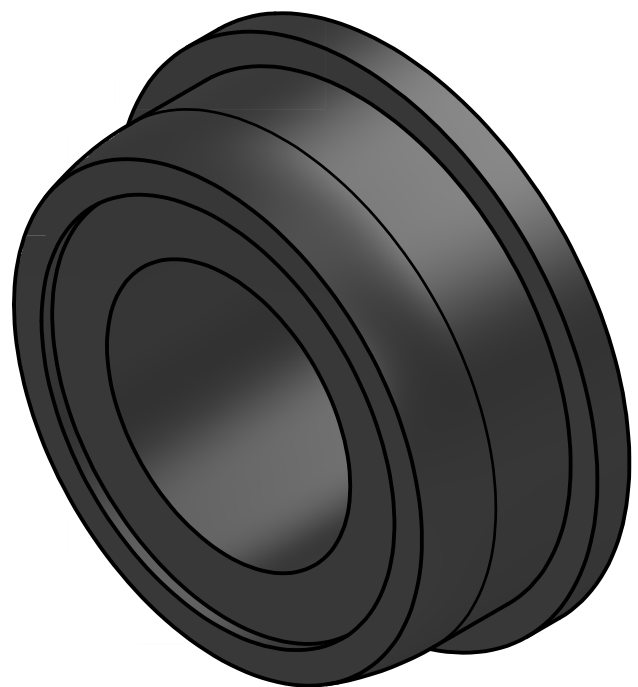

WHEEL AXLE
SCALE 1 : 1

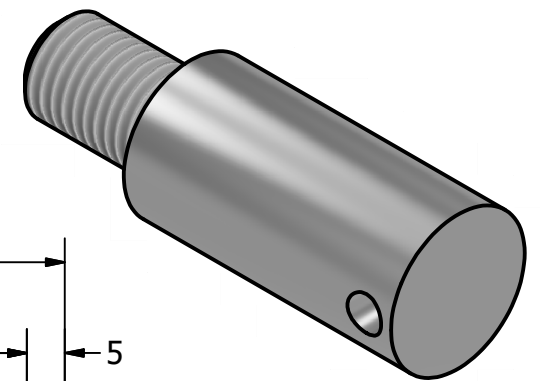

METRIC

PARTS LIST		
ITEM	QTY	PART NUMBER
3	1	HOOK
5	4	WHEEL
6	4	WHEEL AXLE

GENERAL NOTES:

TROLLEY TO BE MOUNTED ON AN S200 X 34 BEAM

ALL CHAMFERS ARE 2 X 2 UNLESS OTHERWISE NOTES



DIGITAL DESIGN
GRAPHICS
TECHNOLOGY

WWW.DDGT.NET

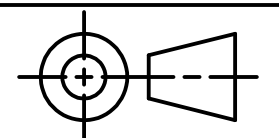

TOLERANCES UNLESS SPECIFIED:
MILLIMETERS:
WHOLE NUMBERS = ±.5
X = ±.25
XX = ±.12
FRACTIONAL ±1/64"
ANGLES ±1 DEGREE
SURFACES 32 ✓

CLASS: DDGT 120

ASSIGNMENT #: 70

INVENTOR DRAWING NAME:
TROLLEY

FIG #: 14-83

MANAGER: G. STROMMEN

DRAFTER: J. DEGRAW

DATE: 11/29/2022

SCALE: AS NOTED

PAGE #: 6 OF 6

LEGEND:

- Ø DIAMETER
- R RADIUS
- ° DEGREES