

PARTS LIST				
ITEM	QTY	PART NUMBER	MATERIAL	DESCRIPTION
2	1	BRACKET	USS STEEL	13 GA (2.38)
4	1	WHEEL	HARD RUBBER	
5	1	BUSHING	BRASS	
6	1	RETAINING RING	STAINLESS STEEL	99179A105- EXT SERIES 5133
5	1	POST	Steel AISI 1118	
6	1	SHAFT	Steel AISI 1118	

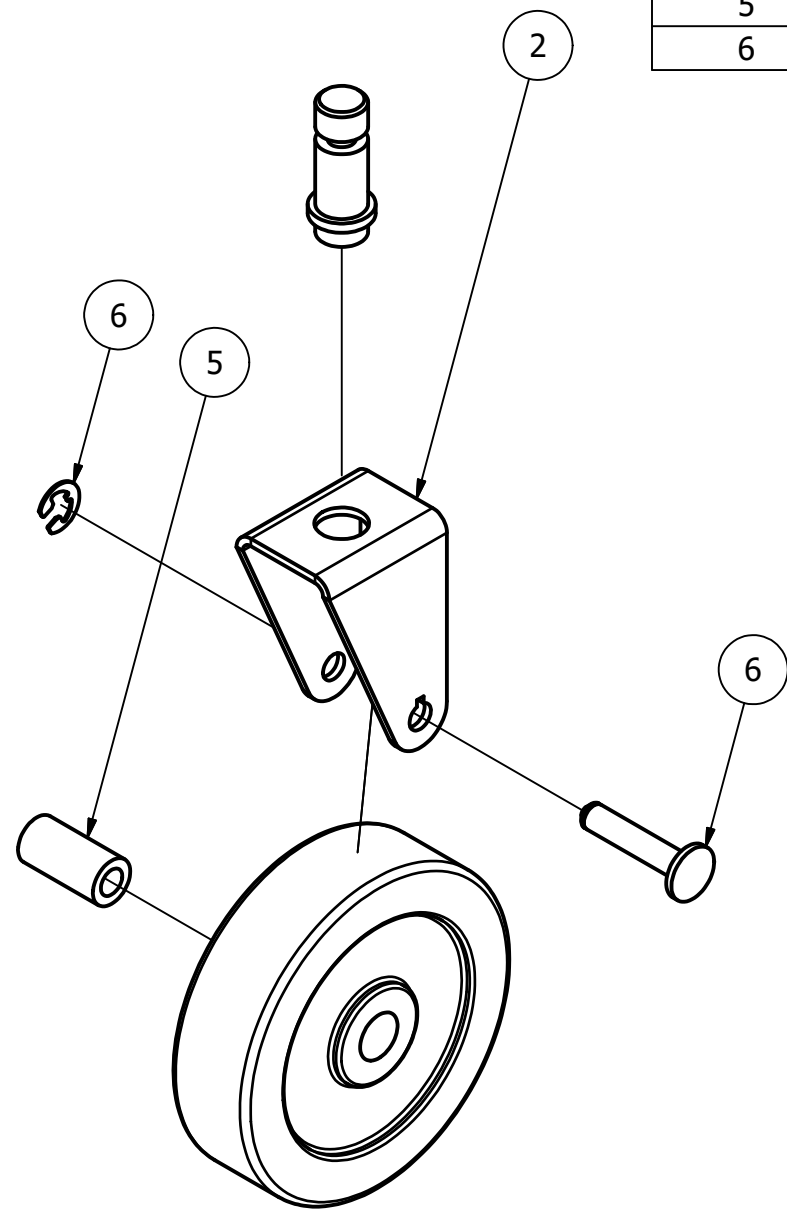

DIGITAL DESIGN
GRAPHICS
TECHNOLOGY

WWW.DDGT.NET



CASTER EXPLODED ASSEMBLY
SCALE 1 / 2

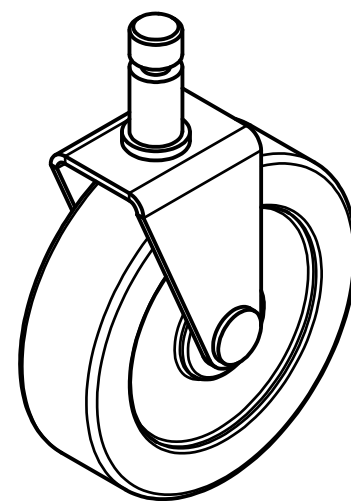

CASTER ASSEMBLY
SCALE 1 / 2

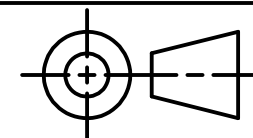

TOLERANCES UNLESS SPECIFIED:
MILLIMETERS:
WHOLE NUMBERS = ±.5
X = ±.25
XX = ±.12
FRACTIONAL ±1/64"
ANGLES ±1 DEGREE
SURFACES ³² ✓

CLASS: DDGT 120

ASSIGNMENT #: 68

INVENTOR DRAWING NAME:
CASTER

FIG #: 14-90

MANAGER: G. STROMMEN

DRAFTER: J. DEGRAW

DATE: 11/15/2022

SCALE: AS NOTED

PAGE #: 1 OF 4

METRIC

LEGEND:

- ∅ DIAMETER
- R RADIUS
- DEGREES

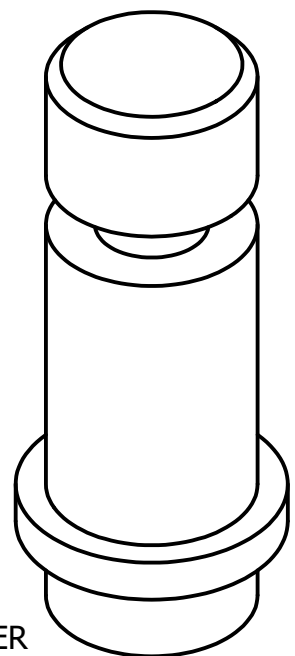

PARTS LIST		
ITEM	QTY	PART NUMBER
5	1	POST
6	1	SHAFT



DIGITAL DESIGN
GRAPHICS
TECHNOLOGY

WWW.DDGT.NET

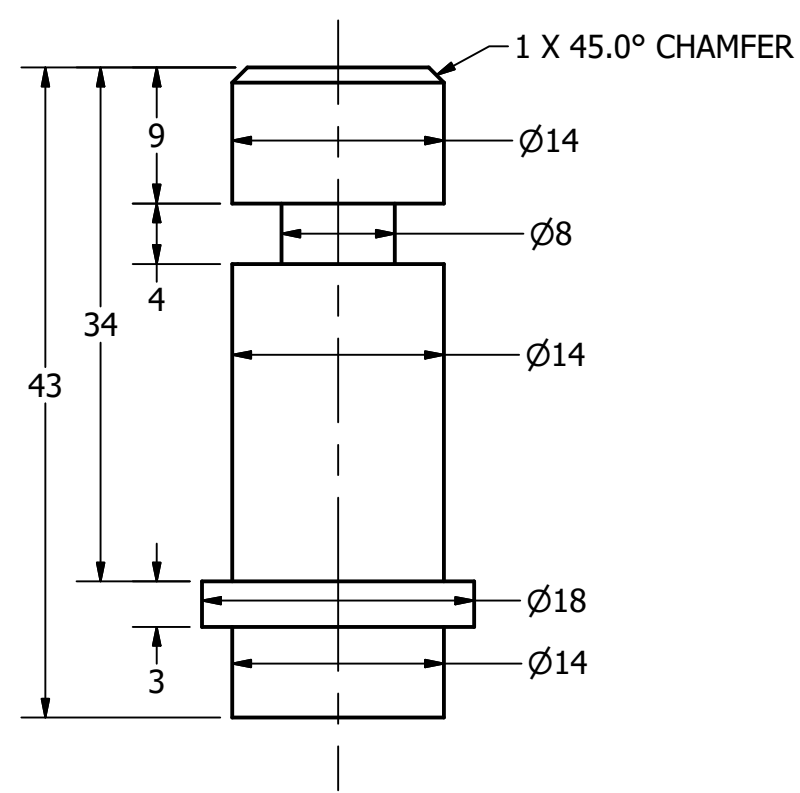

POST
SCALE 2 : 1

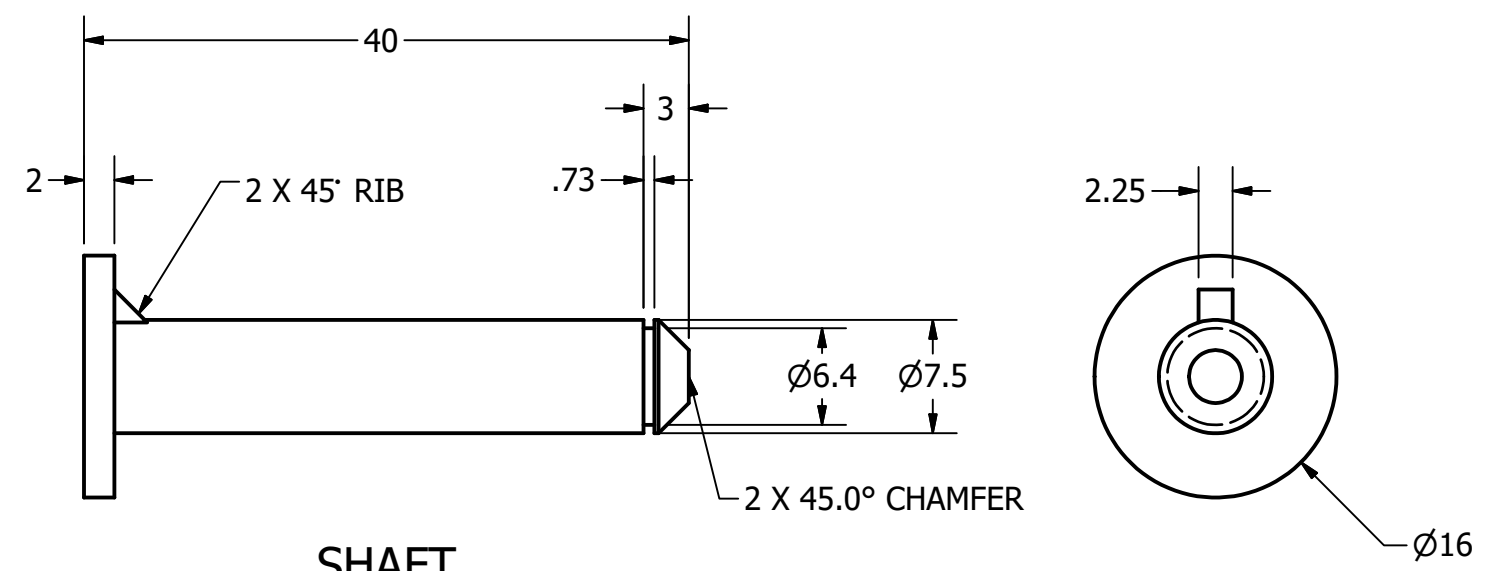

SHAFT
SCALE 2 : 1

METRIC

LEGEND:

- Ø DIAMETER
- R RADIUS
- DEGREES

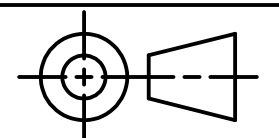

TOLERANCES UNLESS SPECIFIED:
MILLIMETERS:
WHOLE NUMBERS = ±.5
X = ±.25
XX = ±.12
FRACTIONAL ±1/64"
ANGLES ±1 DEGREE
SURFACES 32 ✓

CLASS: DDGT 120

ASSIGNMENT #: 68

INVENTOR DRAWING NAME:
CASTER

FIG #: 14-90

MANAGER: G. STROMMEN

DRAFTER: J. DEGRAW

DATE: 11/15/2022

SCALE: AS NOTED

PAGE #: 2 OF 4

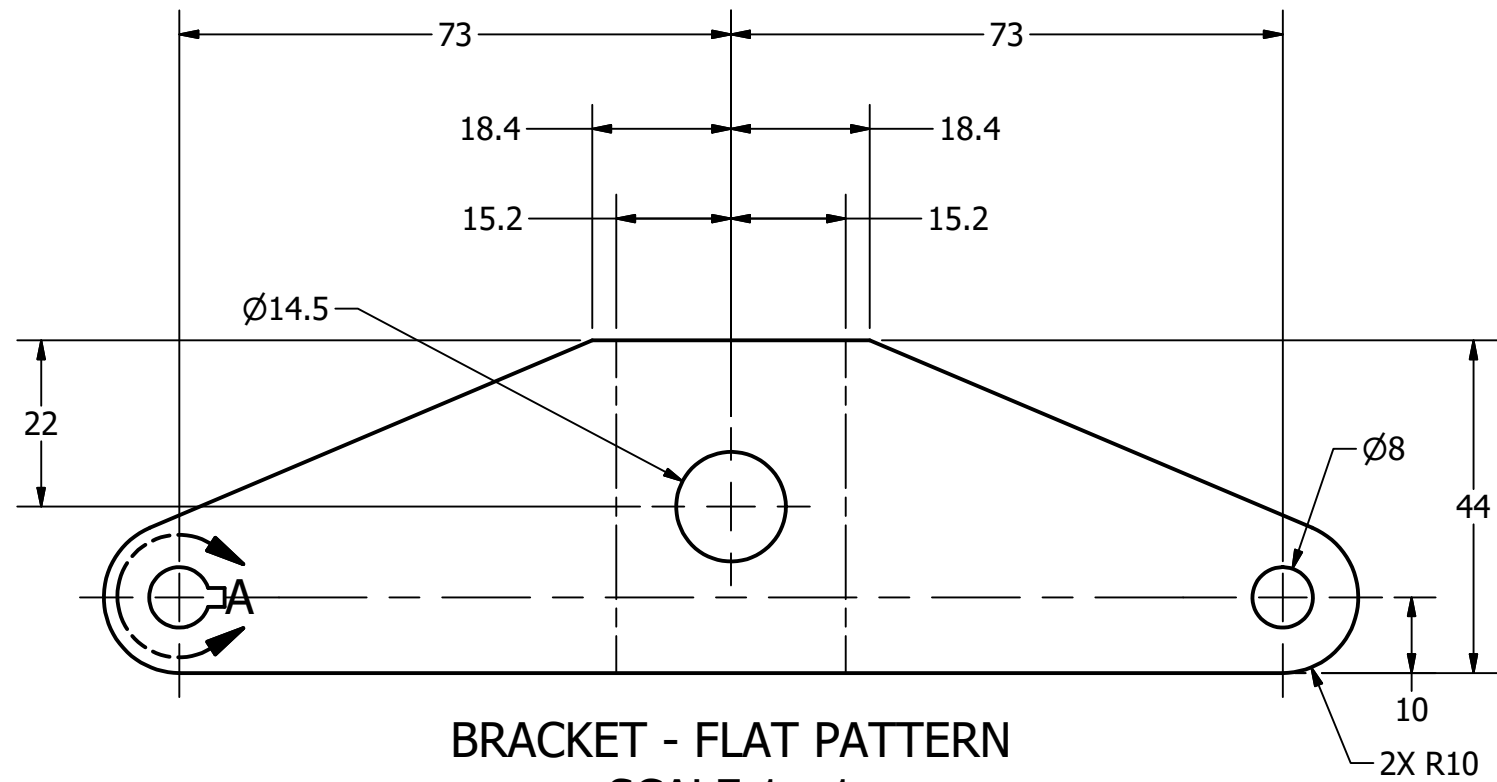

BRACKET - FLAT PATTERN
SCALE 1 : 1

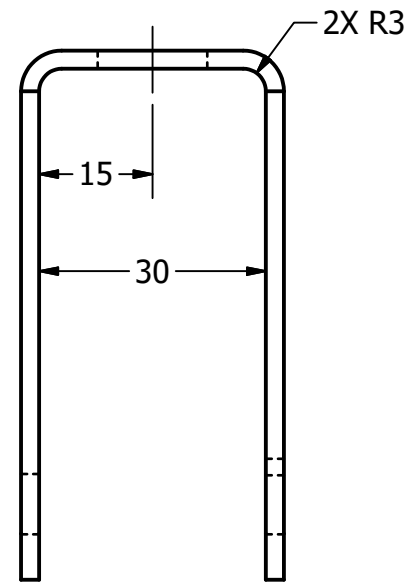

BRACKET FOLDED
SCALE 1 : 1

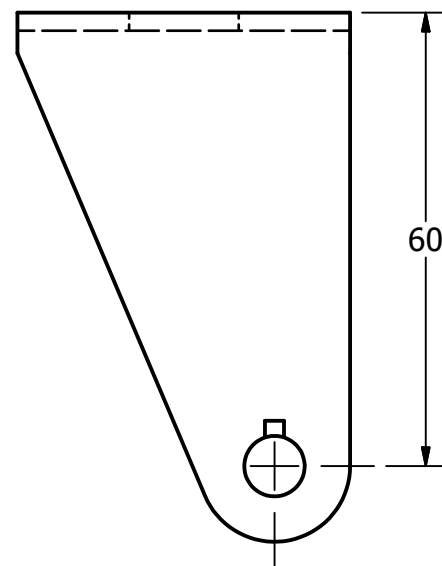

METRIC

LEGEND:

- Ø DIAMETER
- R RADIUS
- ° DEGREES

PARTS LIST		
ITEM	QTY	PART NUMBER
2	1	BRACKET
5	1	POST
6	1	SHAFT

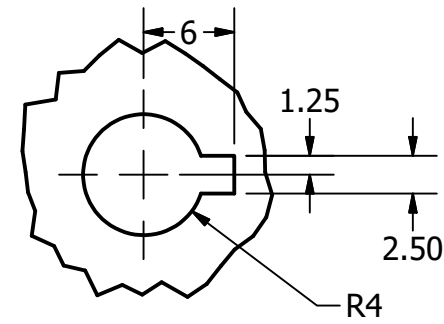

DETAIL A
SCALE 2 : 1

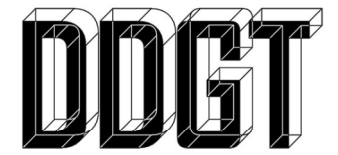
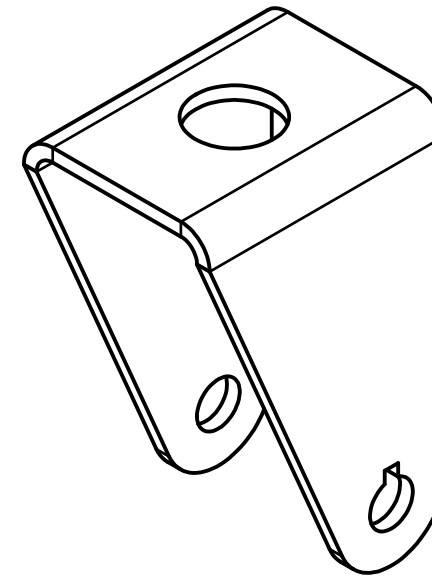

DIGITAL DESIGN
GRAPHICS
TECHNOLOGY

WWW.DDGT.NET

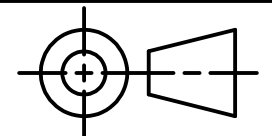

TOLERANCES UNLESS SPECIFIED:
MILLIMETERS:
WHOLE NUMBERS = ±.5
X = ±.25
XX = ±.12
FRACTIONAL ±1/64"
ANGLES ±1 DEGREE
SURFACES $\sqrt{32}$

CLASS: DDGT 120

ASSIGNMENT #: 68

INVENTOR DRAWING NAME:
CASTER

FIG #: 14-90

MANAGER: G. STROMMEN

DRAFTER: J. DEGRAW

DATE: 11/15/2022

SCALE: AS NOTED

PAGE #: 3 OF 4

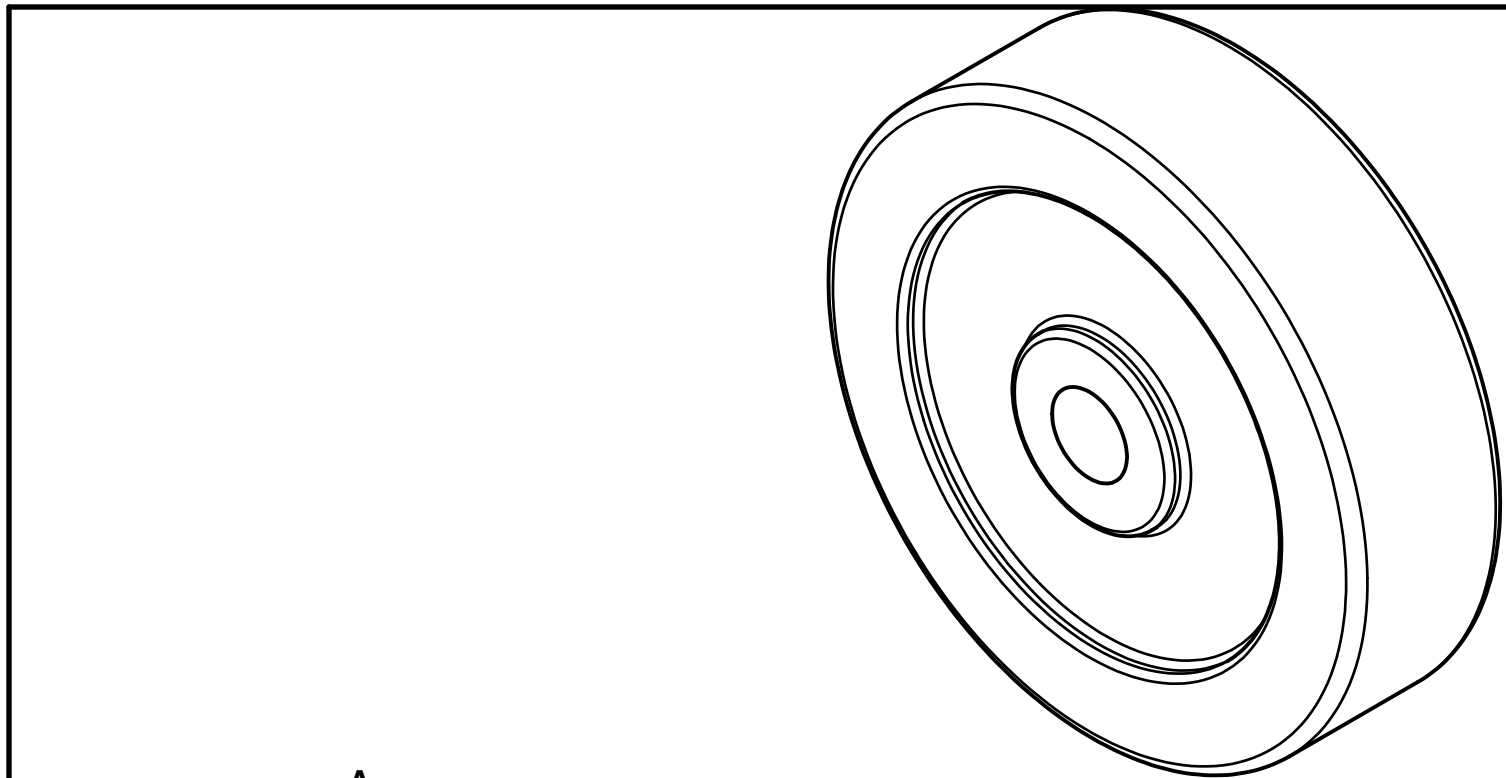

PARTS LIST		
ITEM	QTY	PART NUMBER
4	1	WHEEL
5	1	BUSHING
5	1	POST
6	1	SHAFT



DIGITAL DESIGN
GRAPHICS
TECHNOLOGY

WWW.DDGT.NET

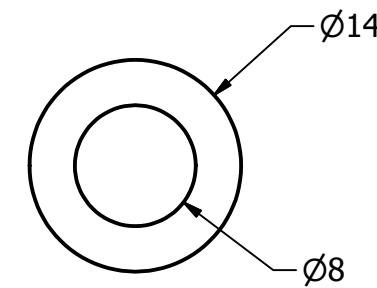
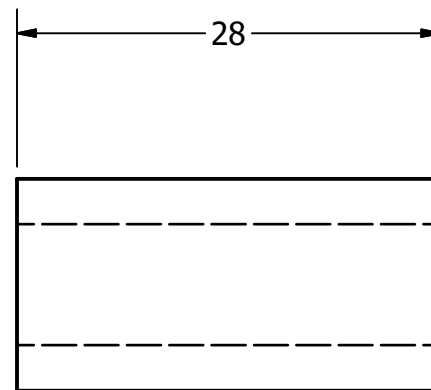
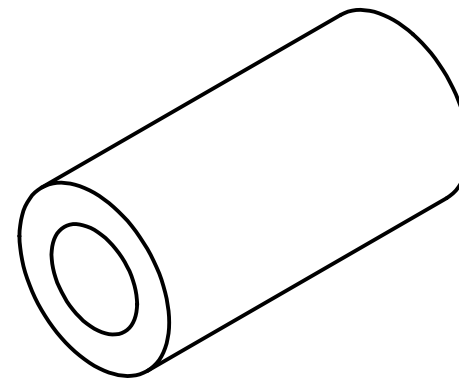

BUSHING
SCALE 2 : 1

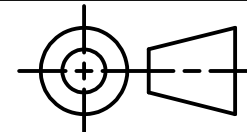

TOLERANCES UNLESS SPECIFIED:
MILLIMETERS:
WHOLE NUMBERS = ±.5
X = ±.25
XX = ±.12
FRACTIONAL ±1/64"
ANGLES ±1 DEGREE
SURFACES ³²✓

CLASS: DDGT 120

ASSIGNMENT #: 68

INVENTOR DRAWING NAME:
CASTER

FIG #: 14-90

MANAGER: G. STROMMEN

DRAFTER: J. DEGRAW

DATE: 11/15/2022

SCALE: AS NOTED

PAGE #: 4 OF 4

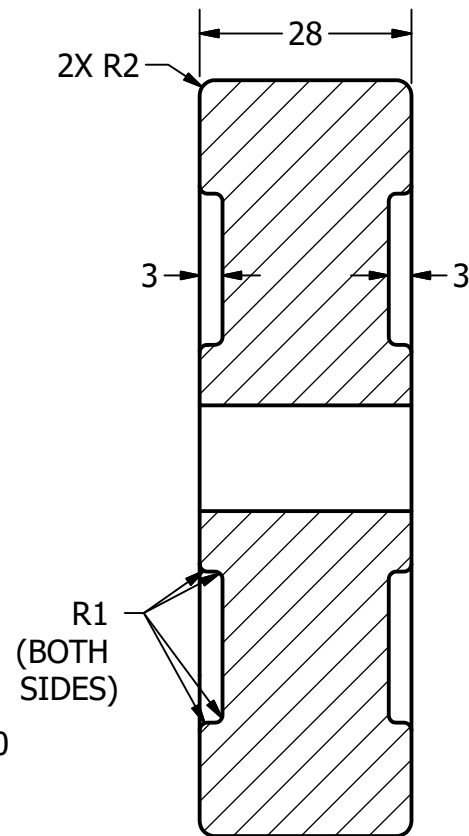
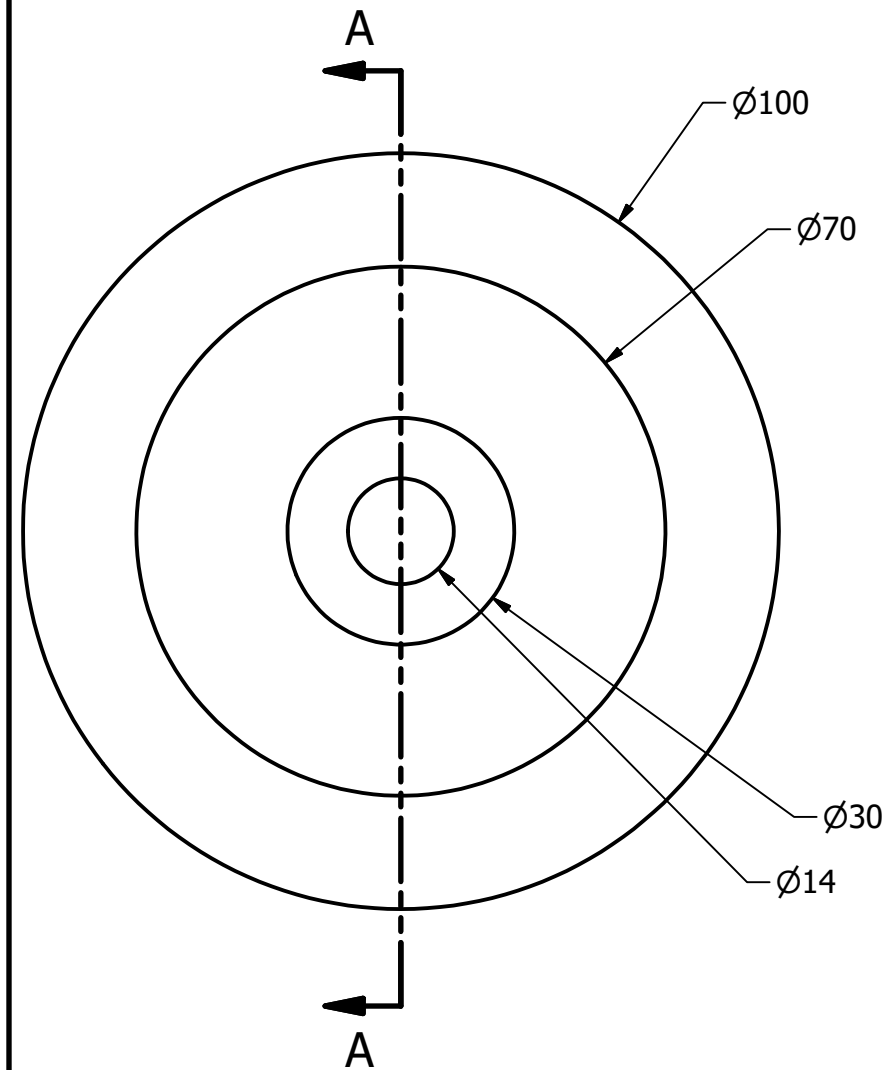

SECTION B-B
SCALE 1 : 1

METRIC

LEGEND:

- ∅ DIAMETER
- R RADIUS
- ° DEGREES