

UPPER PART
SCALE 1 : 1

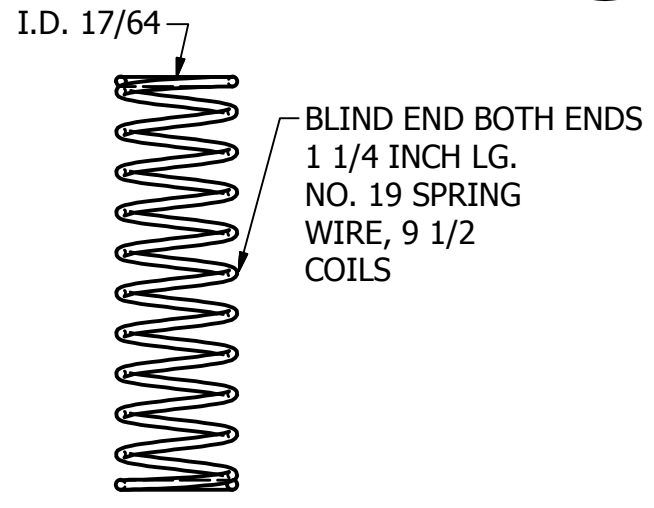

SPRING
SCALE 2 : 1

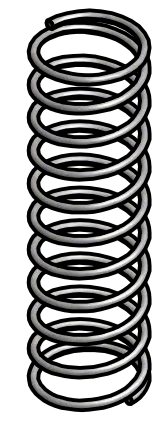
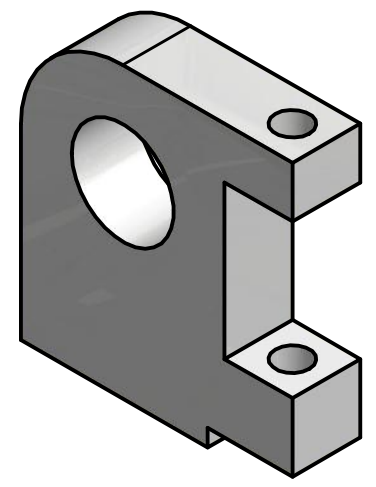
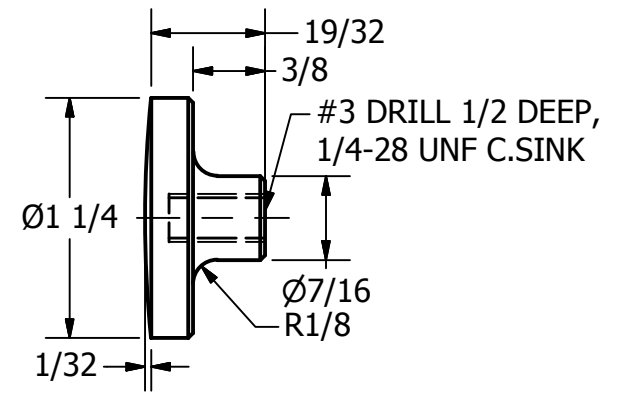
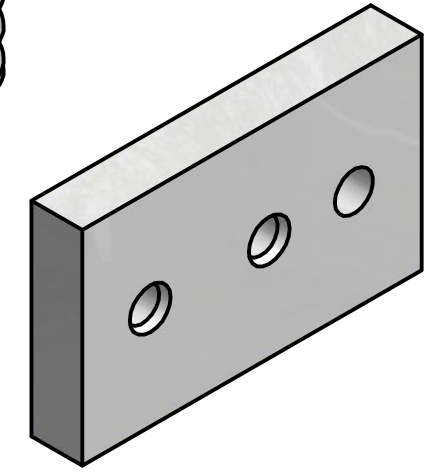

HANDLE
SCALE 1 : 1

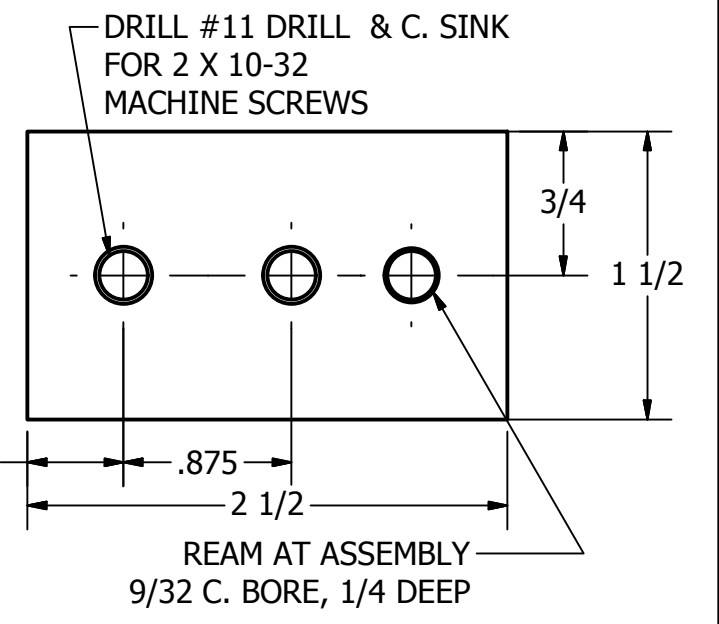
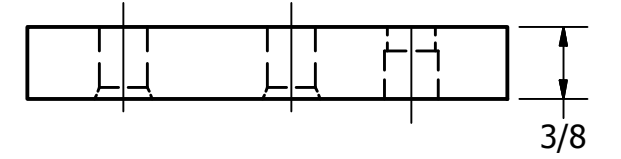
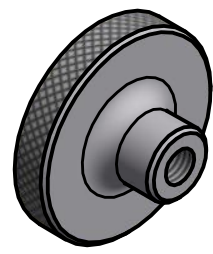

BASE PART
SCALE 1 : 1

PARTS LIST		
ITEM	QTY	PART NUMBER
1	1	BASE PART
2	1	UPPER PART
3	1	POST
4	1	HANDLE
5	1	WASHER
6	1	SPRING

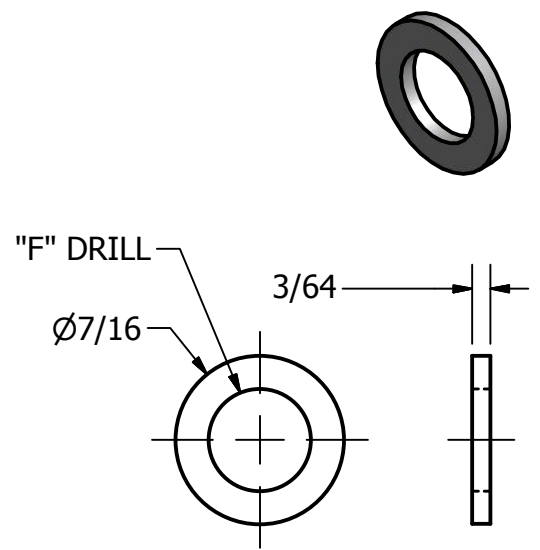
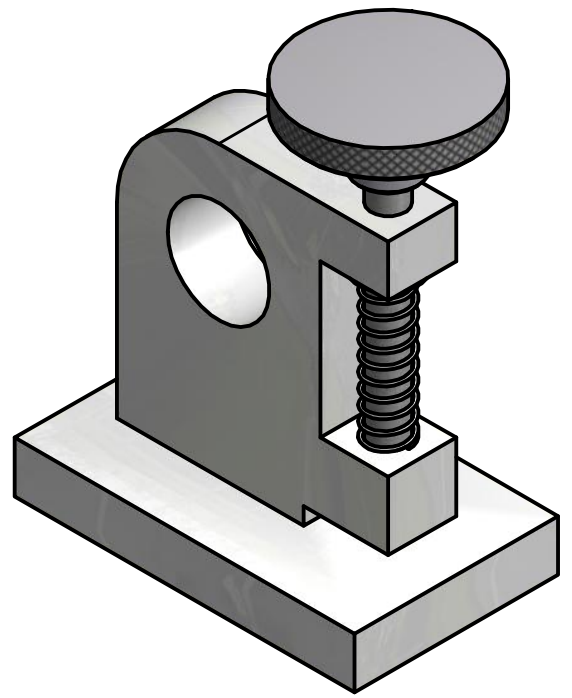
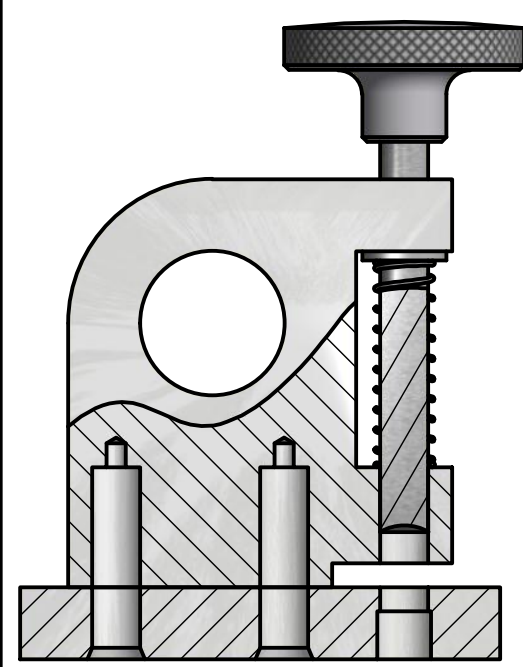

WASHER
SCALE 2 : 1

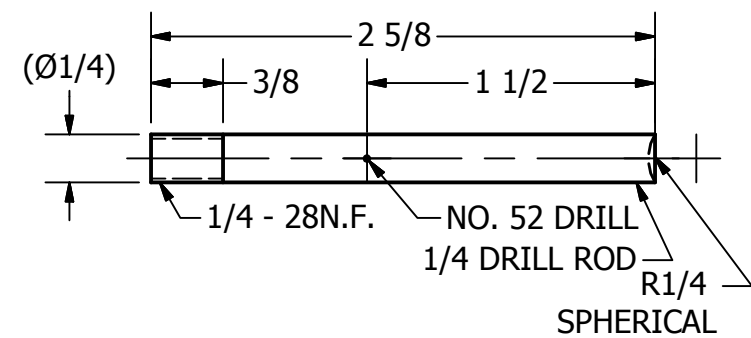

POST
SCALE 1 : 1

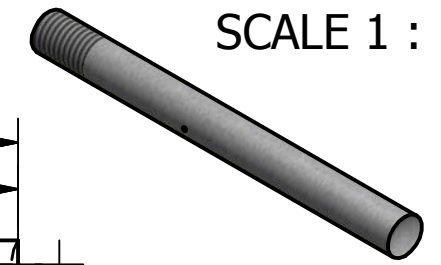

DRAWN BY: J. KISIEL	SCALE: 1:1	DATE: 4/23/2011
------------------------	---------------	--------------------

PAPER PUNCH