

PARTS LIST			
ITEM	QTY	PART NUMBER	MATERIAL
1	1	BASE	Iron, Cast
2	1	WISE SCREW	SAE 3140
3	2	JAW PLATE	SAE 3140
4	1	COLLAR	SAE 1020
5	2	SET SCREW	Steel AISI 1015 80 NORM
6	1	SPECIAL KEY	SAE 1020
7	4	91781A539 McMaster Carr Slotted Flat Head Screw 1/4"x20x5/8"	Stainless Steel AISI 304
8	2	HANDLE BALL	SAE 1020
9	1	HANDLE ROD	CRS
10	1	SLIDING JAW	Iron, Cast
11	2	SLIDE KEY	SAE 1020
12	2	TAPER PIN	CRS

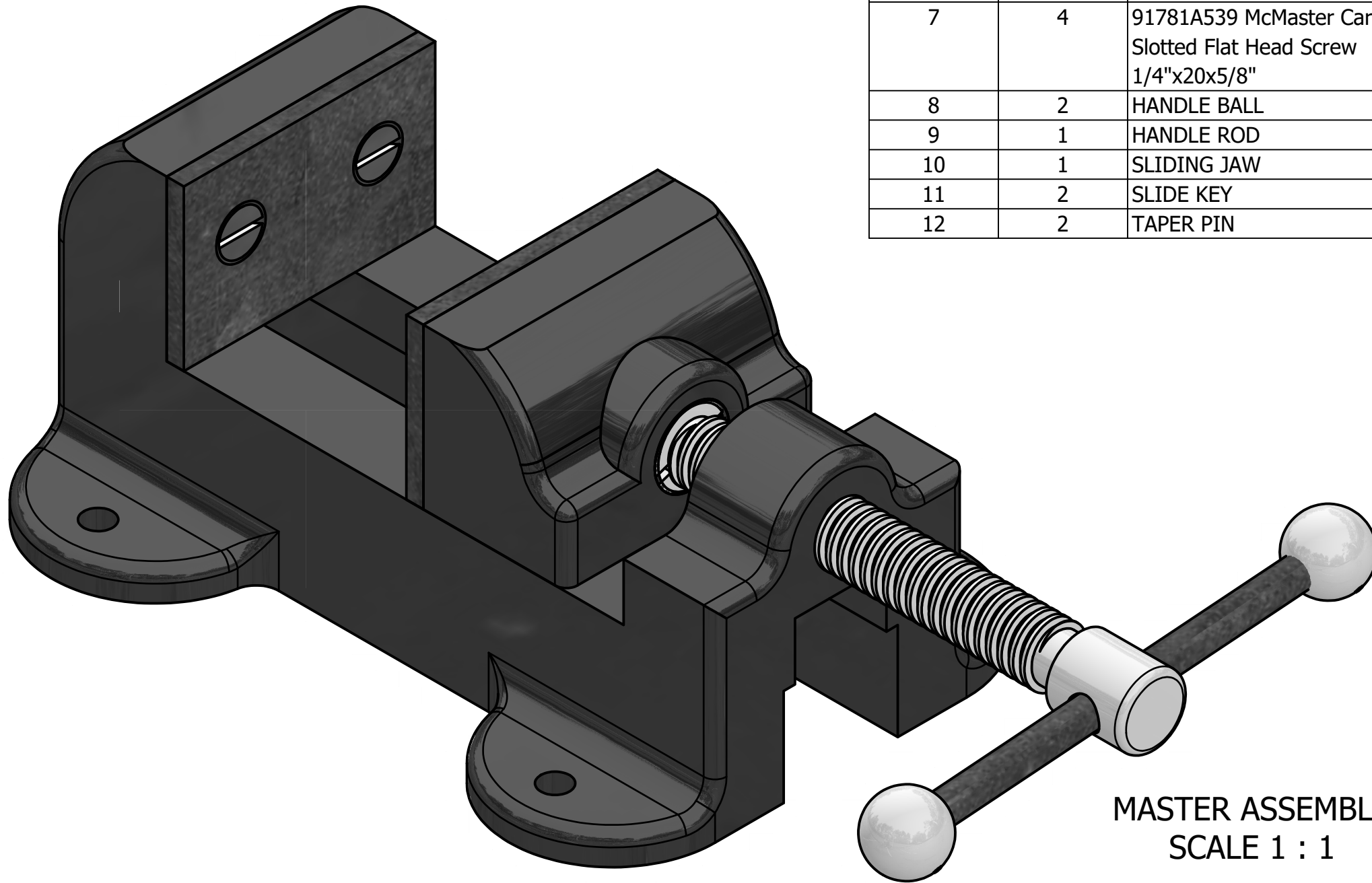

MASTER ASSEMBLY
SCALE 1 : 1

GENERAL NOTES:

ALL FILLETS AND ROUNDS 1/8" UNLESS OTHERWISE NOTED.



DIGITAL DESIGN
GRAPHICS
TECHNOLOGY

WWW.DDGT.NET

LOVES 3D PRINTING AND DESIGN
 KEN LOVE OWNER
 lov3s3dprinting@gmail.com
 www.ddgt.net/StudentPages/love66526

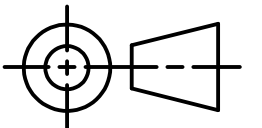

TOLERANCES UNLESS SPECIFIED:
 DECIMAL INCHES:
 X = ±.020
 XX = ±.010
 XXX = ±.005
 FRACTIONAL ±1/64"
 ANGLES ±1 DEGREE
 SURFACES $\sqrt{32}$

CLASS:	DDGT 240
ASSIGNMENT #:	38
INVENTOR DRAWING NAME:	MACHINE VISE
FIG #:	14-71
MANAGER:	G. STROMMEN
DRAFTER:	Ken
DATE:	9/26/2023
SCALE:	AS NOTED
PAGE #:	1 OF 5

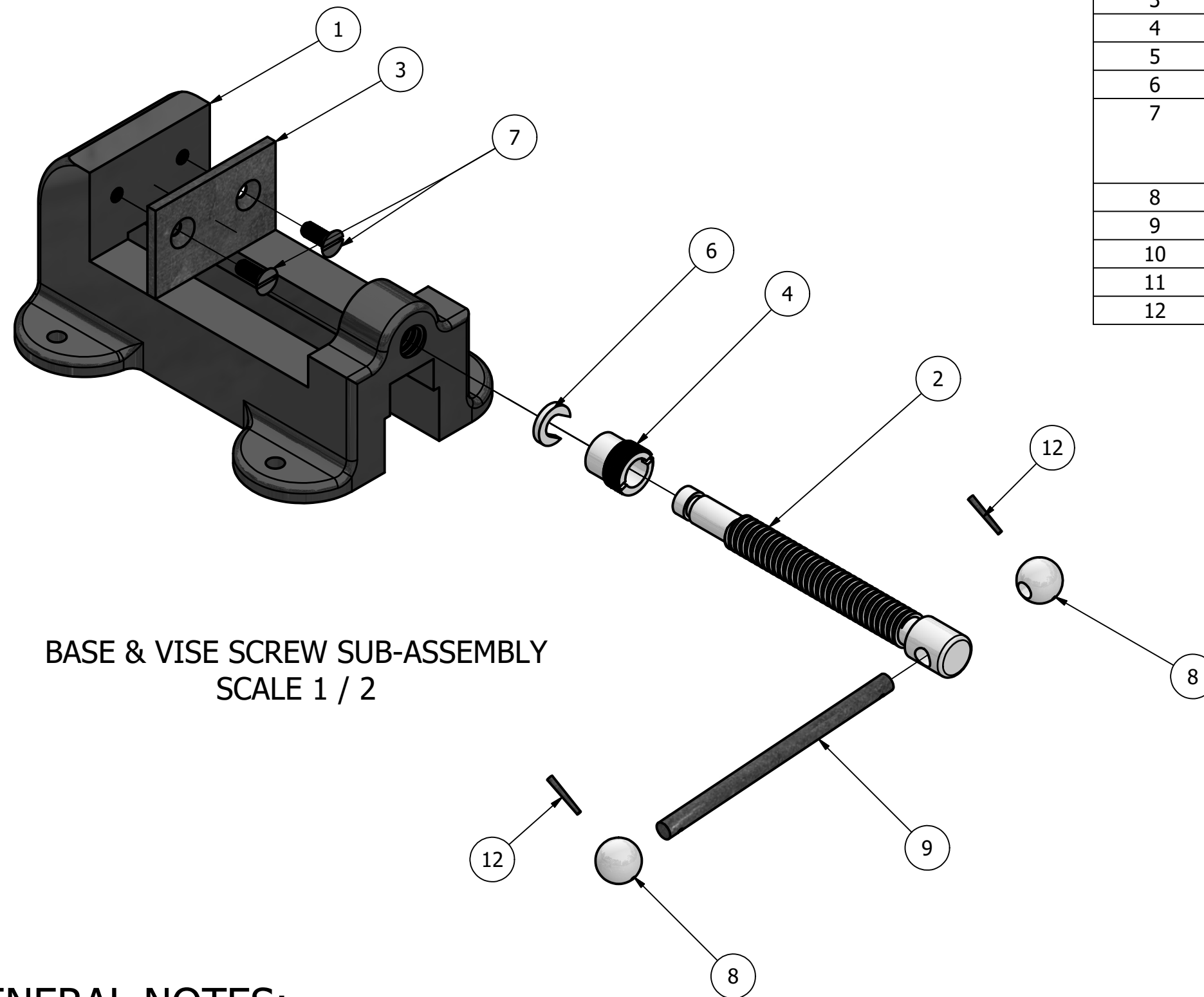

PARTS LIST		
ITEM	QTY	PART NUMBER
1	1	BASE
2	1	WISE SCREW
3	2	JAW PLATE
4	1	COLLAR
5	2	SET SCREW
6	1	SPECIAL KEY
7	4	91781A539 McMaster Carr Slotted Flat Head Screw 1/4"x20x5/8"
8	2	HANDLE BALL
9	1	HANDLE ROD
10	1	SLIDING JAW
11	2	SLIDE KEY
12	2	TAPER PIN



DIGITAL DESIGN
GRAPHICS
TECHNOLOGY

WWW.DDGT.NET

LOVES 3D PRINTING AND DESIGN
 KEN LOVE OWNER
 lov3s3dprinting@gmail.com
 www.ddgt.net/StudentPages/love66526

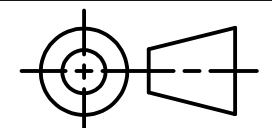

TOLERANCES UNLESS SPECIFIED:
 DECIMAL INCHES:
 X = ±.020
 XX = ±.010
 XXX = ±.005
 FRACTIONAL ±1/64"
 ANGLES ±1 DEGREE
 SURFACES $\sqrt{\text{32}}$

CLASS: DDGT 240

ASSIGNMENT #: 38

INVENTOR DRAWING NAME:
MACHINE VISE

FIG #: 14-71

MANAGER: G. STROMMEN

DRAFTER: Ken

DATE: 9/26/2023

SCALE: AS NOTED

PAGE #: 2 OF 5

LEGEND:

- ∅ DIAMETER
- R RADIUS
- ° DEGREES
- √ COUNTERSINK
- ∇ DEPTH

GENERAL NOTES:

ALL FILLETS AND ROUNDS 1/8" UNLESS OTHERWISE NOTED.

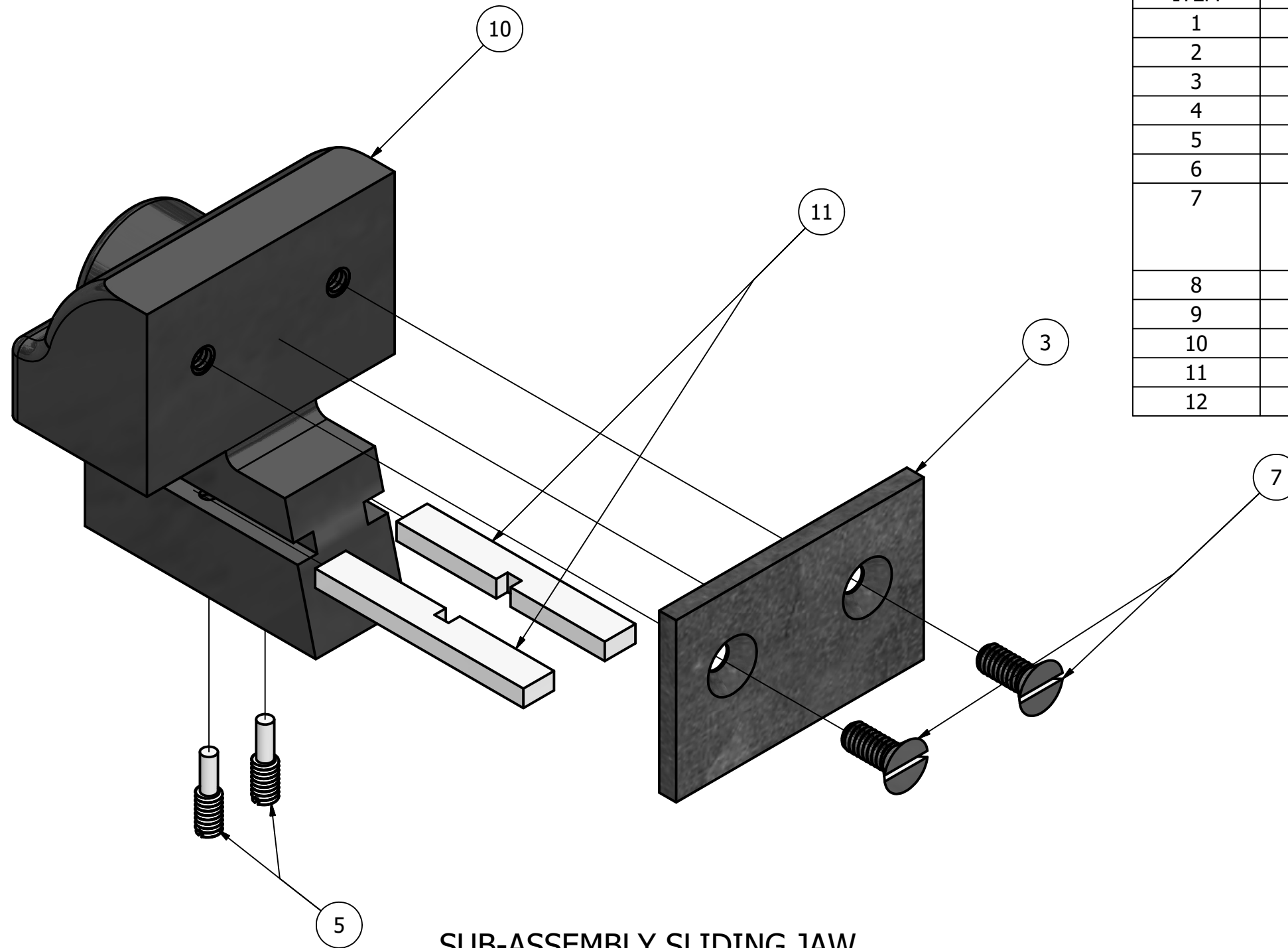

SUB-ASSEMBLY SLIDING JAW
SCALE 1 : 1

PARTS LIST		
ITEM	QTY	PART NUMBER
1	1	BASE
2	1	WISE SCREW
3	2	JAW PLATE
4	1	COLLAR
5	2	SET SCREW
6	1	SPECIAL KEY
7	4	91781A539 McMaster Carr Slotted Flat Head Screw 1/4"x20x5/8"
8	2	HANDLE BALL
9	1	HANDLE ROD
10	1	SLIDING JAW
11	2	SLIDE KEY
12	2	TAPER PIN



DIGITAL DESIGN
GRAPHICS
TECHNOLOGY

WWW.DDGT.NET

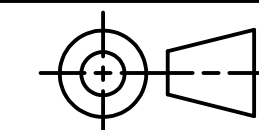

TOLERANCES UNLESS SPECIFIED:
DECIMAL INCHES:
X = ±.020
XX = ±.010
XXX = ±.005
FRACTIONAL ±1/64"
ANGLES ±1 DEGREE
SURFACES $\sqrt{32}$

CLASS: DDGT 240

ASSIGNMENT #: 38

INVENTOR DRAWING NAME:
MACHINE VISE

FIG #: 14-71

MANAGER: G. STROMMEN

DRAFTER: Ken

DATE: 9/26/2023

SCALE: AS NOTED

PAGE #: 3 OF 5

GENERAL NOTES:

ALL FILLETS AND ROUNDS 1/8" UNLESS OTHERWISE NOTED.

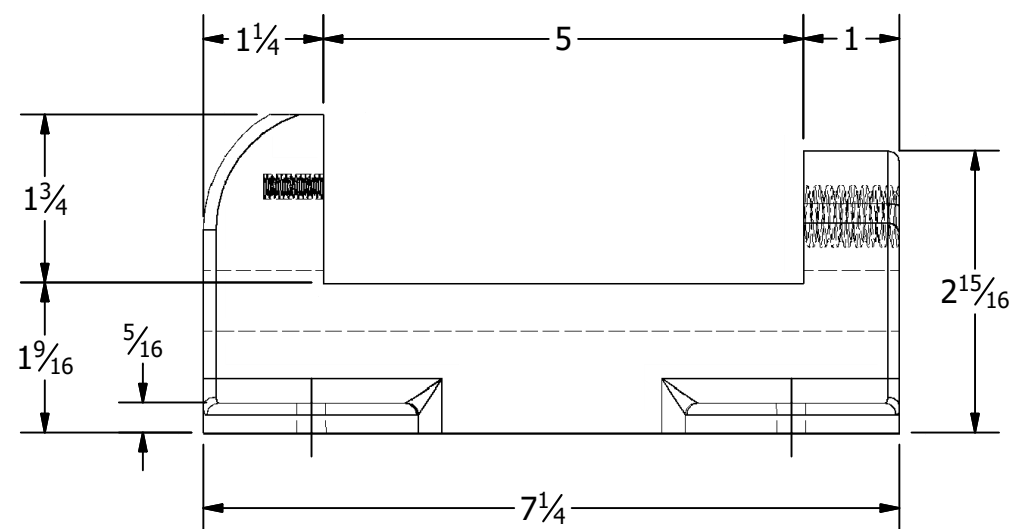
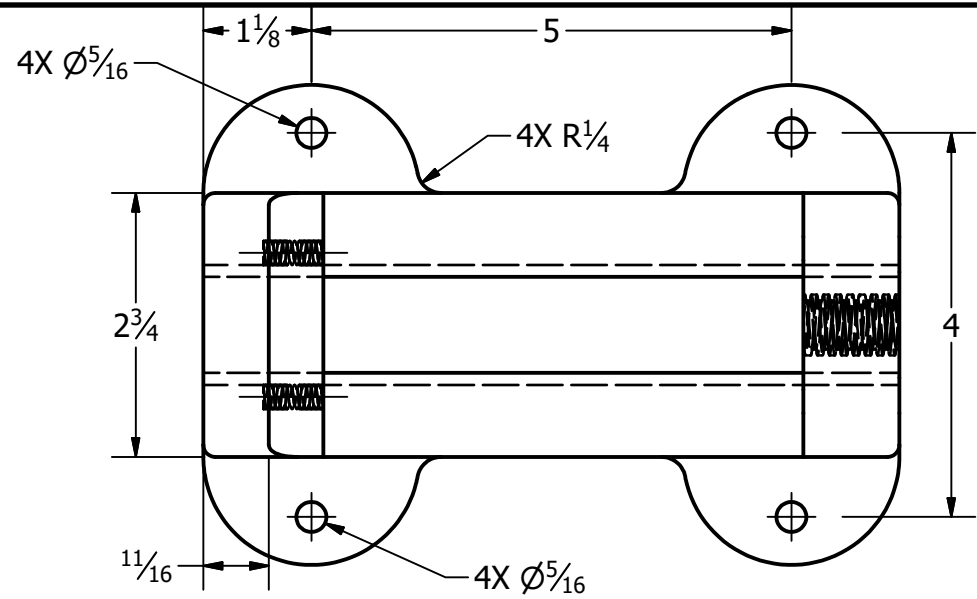

BASE
SCALE 1 / 2

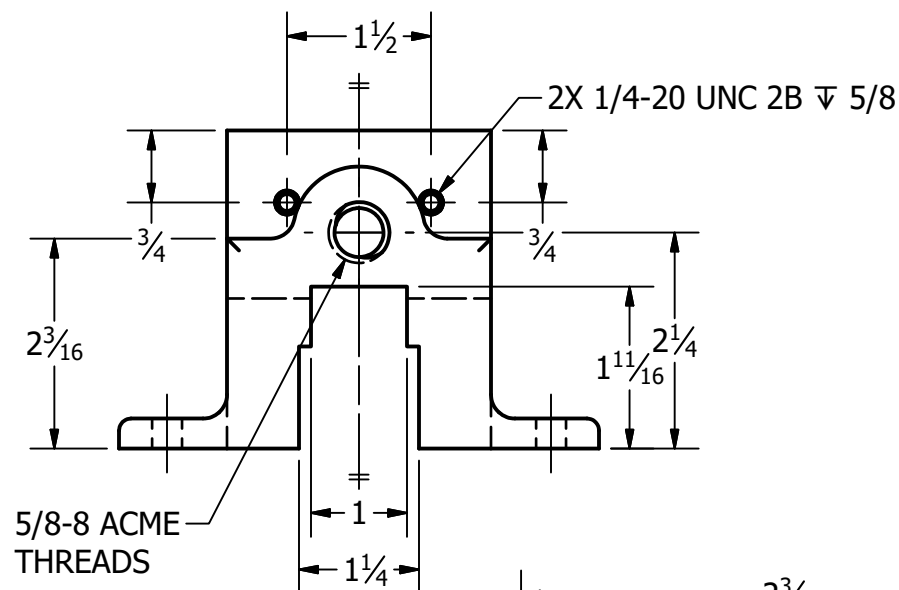

2X ∇ 1/4 FLAT HEAD
MACHINE SCREW

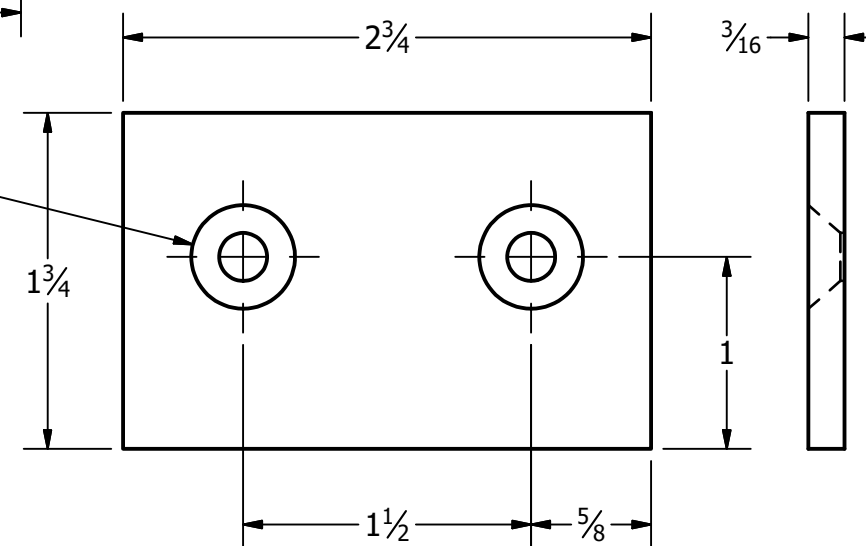

JAW PLATE
SCALE 1 : 1

PARTS LIST			
ITEM	QTY	PART NUMBER	DESCRIPTION
1	1	BASE	
3	2	JAW PLATE	



DIGITAL DESIGN
GRAPHICS
TECHNOLOGY

WWW.DDGT.NET

LOVES 3D PRINTING AND DESIGN
KEN LOVE OWNER
lov3s3dprinting@gmail.com
www.ddgt.net/StudentPages/love66526

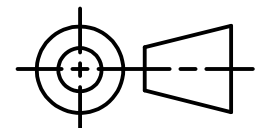

TOLERANCES UNLESS SPECIFIED:
DECIMAL INCHES:
X = ±.020
XX = ±.010
XXX = ±.005
FRACTIONAL ±1/64"
ANGLES ±1 DEGREE
SURFACES $\sqrt{32}$

CLASS: DDGT 240

ASSIGNMENT #: 38

INVENTOR DRAWING NAME:
MACHINE VISE

FIG #: 14-71

MANAGER: G. STROMMEN

DRAFTER: Ken

DATE: 9/26/2023

SCALE: AS NOTED

PAGE #: 4 OF 5

GENERAL NOTES:

ALL FILLETS AND ROUNDS 1/8" UNLESS OTHERWISE NOTED.

LEGEND:

- Ø DIAMETER
- R RADIUS
- ° DEGREES
- ∇ COUNTERSINK
- ∇ DEPTH

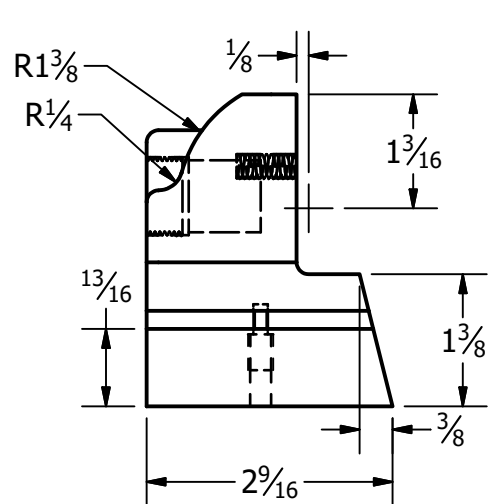
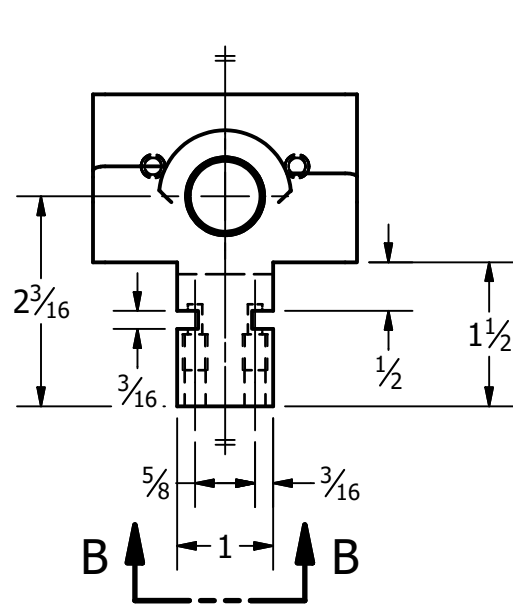

SLIDING JAW
SCALE 1 / 2

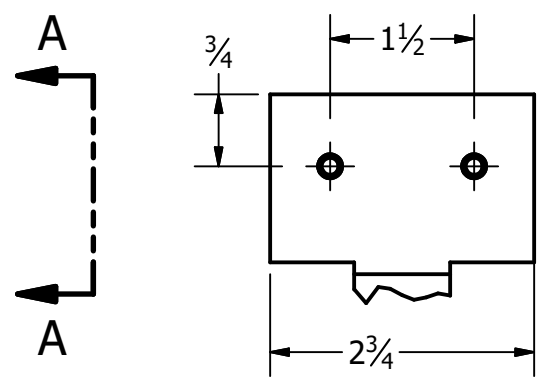

VIEW A-A
SCALE 1 / 2

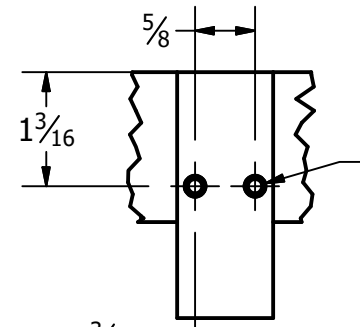

VIEW B-B
SCALE 1 / 2

2X'S #25 DRILL 1 1/16 ∇
#12 DRILL 24UNC-2B ∇ 3/4
7/32 L 3/8 ∇

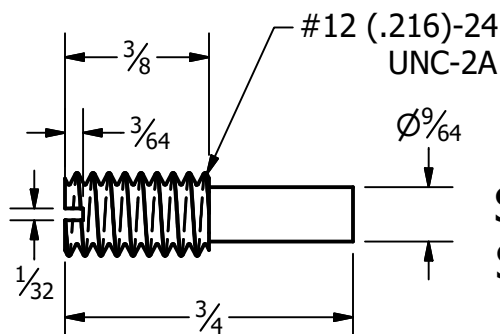

SET SCREW
SCALE 2 : 1

"M" .295 DRILL ∇ 1/2
REAM .313

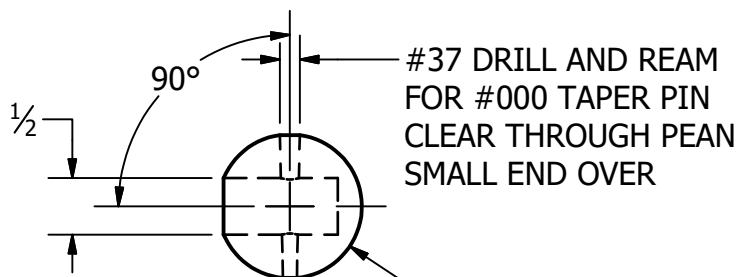

HANDLE BALL
SCALE 1 : 1

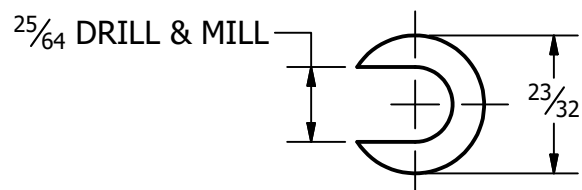

SPECIAL KEY
SCALE 1 : 1

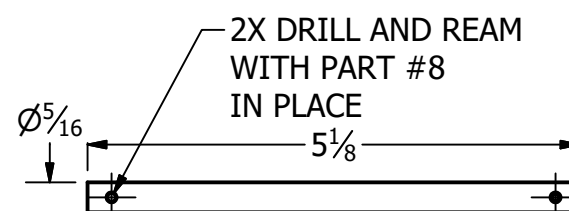
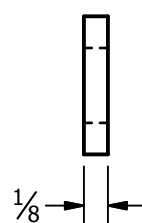

HANDLE ROD
SCALE 1 / 2

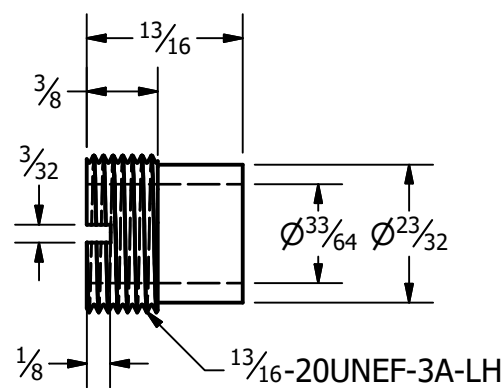

COLLAR
SCALE 1 : 1

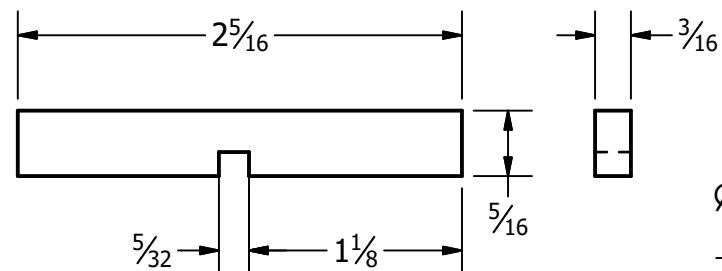

SLIDE KEY
SCALE 1 : 1

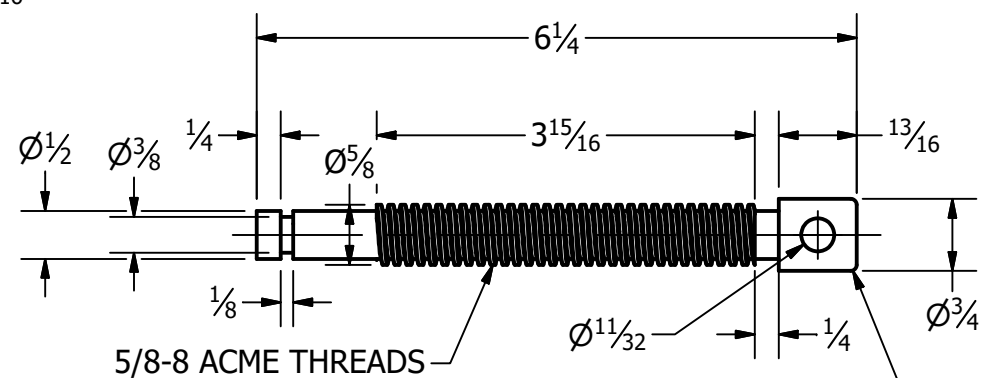

WISE SCREW
SCALE 1 / 2

PARTS LIST		
ITEM	QTY	PART NUMBER
2	1	WISE SCREW
4	1	COLLAR
5	2	SET SCREW
6	1	SPECIAL KEY
8	2	HANDLE BALL
9	1	HANDLE ROD
10	1	SLIDING JAW
11	2	SLIDE KEY

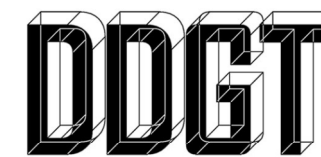

DIGITAL DESIGN
GRAPHICS
TECHNOLOGY

WWW.DDGT.NET

LOVES 3D PRINTING AND DESIGN
KEN LOVE OWNER
lov3s3dprinting@gmail.com
www.ddgt.net/StudentPages/love66526

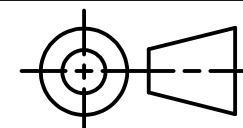

TOLERANCES UNLESS SPECIFIED:
DECIMAL INCHES:
X = ±.020
XX = ±.010
XXX = ±.005
FRACTIONAL ±1/64"
ANGLES ±1 DEGREE
SURFACES 32 ✓

CLASS: DDGT 240

ASSIGNMENT #: 38

INVENTOR DRAWING NAME:
MACHINE VISE

FIG #: 14-71

MANAGER: G. STROMMEN

DRAFTER: Ken

DATE: 9/26/2023

SCALE: AS NOTED

PAGE #: 5 OF 5

GENERAL NOTES:

ALL FILLETS AND ROUNDS 1/8" UNLESS OTHERWISE NOTED.

LEGEND:

- Ø DIAMETER
- R RADIUS
- ° DEGREES
- ✓ COUNTERSINK
- ∇ DEPTH