

MACHINE VISE EXPLODED  
SCALE 1 / 2

PARTS LIST				
ITEM	QTY	PART NUMBER	MATERIAL	DESCRIPTION
1	1	BASE	CAST STEEL	
2	1	SLIDING JAW	CAST STEEL	
3	2	JAW PLATE	SAE-1020	
4	1	WISE SCREW	SAE-1020	
5	1	COLLAR	SAE-1020	
6	1	KEY	SAE-1020	
7	1	HANDLE ROD	COLD ROLLED STEEL	
8	2	HANDLE BALL	SAE-1020	
9	2	SLIDE KEY	SAE-1020	
10	2	SET SCREW	SAE-1020	
12	2	TAPER PIN	TYP.	SIZE #000 TAPER PIN

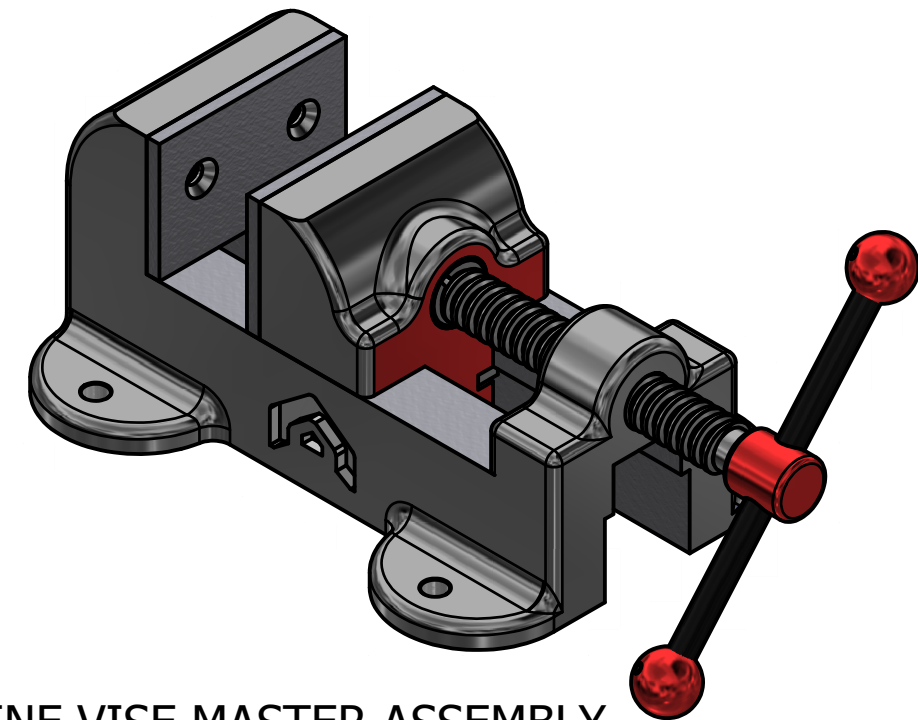

MACHINE VISE MASTER ASSEMBLY  
SCALE 1 / 2

**GENERAL NOTES:**

ALL ROUNDS AND FILLETS R.125 UNLESS OTHERWISE NOTED

**LEGEND:**

- ∅ DIAMETER
- R RADIUS
- ° DEGREES
- ┌ COUNTERBORE
- ▽ DEPTH
- ∨ COUNTERSINK



DIGITAL DESIGN  
GRAPHICS  
TECHNOLOGY

WWW.DDGT.NET



JAYRACHEL92@GMAIL.COM  
DDGT.NET/STUDENTPAGES/JRACHEL

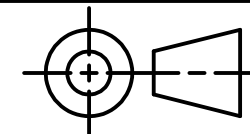

TOLERANCES UNLESS SPECIFIED:  
DECIMAL INCHES  
X = ±.020  
XX = ±.010  
XXX = ±.005  
FRACTIONAL ±1/64"  
ANGLES ±1 DEGREE  
SURFACES 32 ✓

COURSE: DDGT 240

INVENTOR DRAWING NAME:  
MACHINE VISE

FIG #: 14-71

DRAFTER: J. RACHEL

DATE: 10/15/2018

SCALE: AS NOTED

PAGE #: 1 OF 3

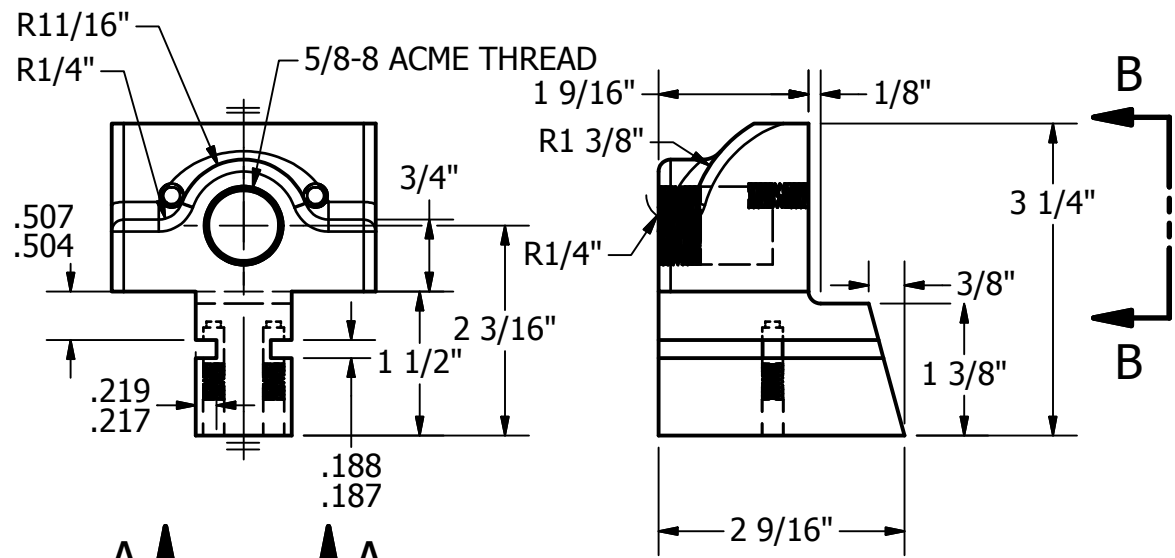

SLIDING JAW  
SCALE 1 / 2

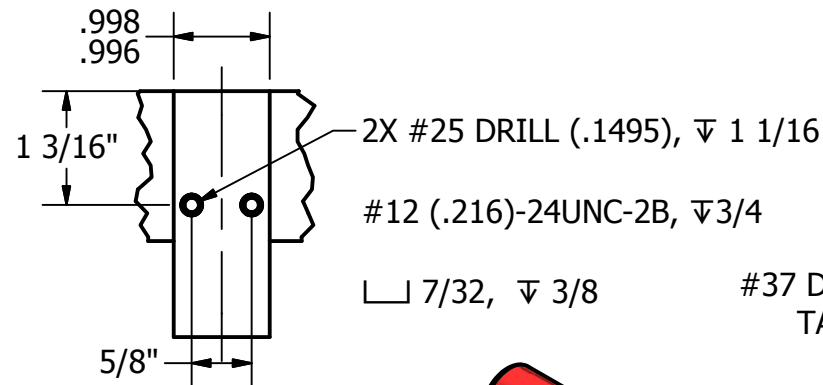

VIEW A-A  
SCALE 1 / 2

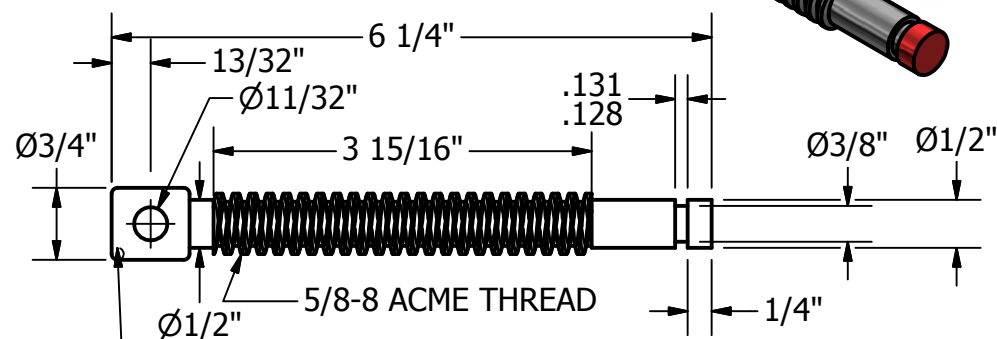

1/16" VISE SCREW  
SCALE 1 / 2

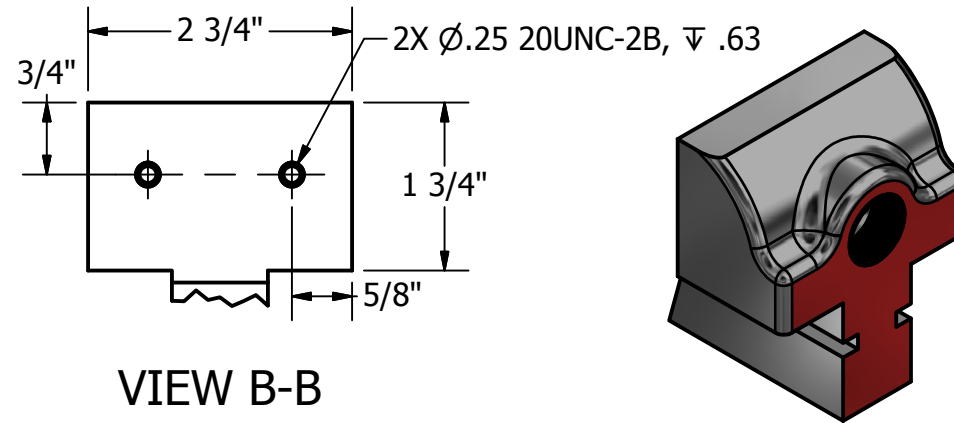

VIEW B-B  
SCALE 1 / 2

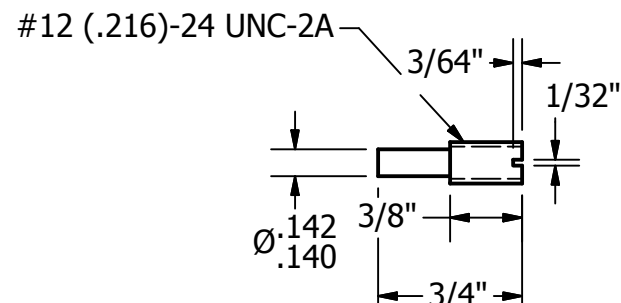

SET SCREW  
SCALE 1 : 1

#37 DRILL AND REAM FOR #000  
TAPER PIN CLEAR THROUGH  
PEEN SMALL END OVER

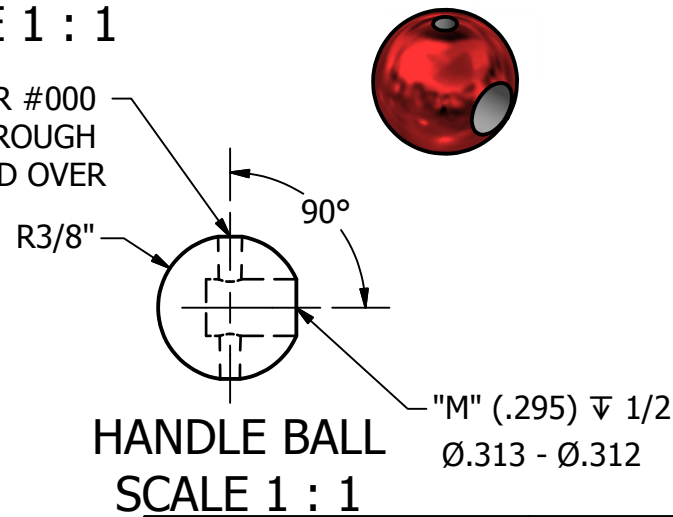

HANDLE BALL  
SCALE 1 : 1

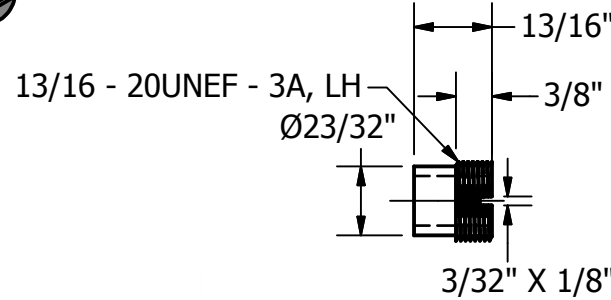

COLLAR  
SCALE 1 / 2

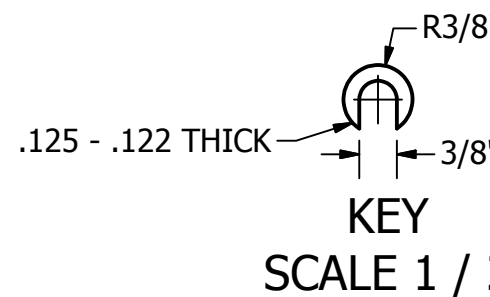

KEY  
SCALE 1 / 2

PARTS LIST		
ITEM	QTY	PART NUMBER
2	1	SLIDING JAW
3	2	JAW PLATE
4	1	WISE SCREW
5	1	COLLAR
6	1	KEY
8	2	HANDLE BALL
10	2	SET SCREW

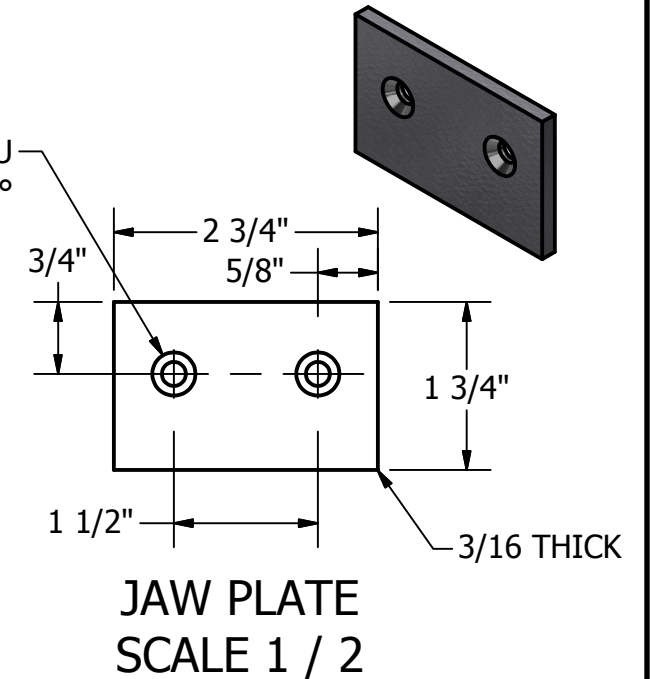

JAW PLATE  
SCALE 1 / 2

**LEGEND:**

- Ø DIAMETER
- R RADIUS
- ° DEGREES
- COUNTERBORE
- ∇ DEPTH
- ✓ COUNTERSINK

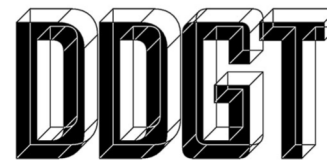

DIGITAL DESIGN  
GRAPHICS  
TECHNOLOGY

WWW.DDGT.NET

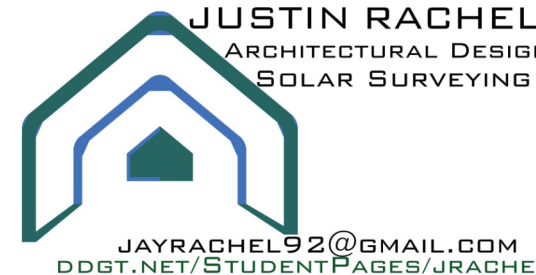

JAYRACHEL92@GMAIL.COM  
DDGT.NET/STUDENTPAGES/JRACHEL

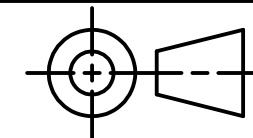

TOLERANCES UNLESS SPECIFIED:  
DECIMAL INCHES  
X = ±.020  
XX = ±.010  
XXX = ±.005  
FRACTIONAL ±1/64"  
ANGLES ±1 DEGREE  
SURFACES 32 ✓

COURSE: DDGT 240

INVENTOR DRAWING NAME:  
MACHINE VISE

FIG #: 14-71

DRAFTER: J. RACHEL

DATE: 10/15/2018

SCALE: AS NOTED

PAGE #: 2 OF 3

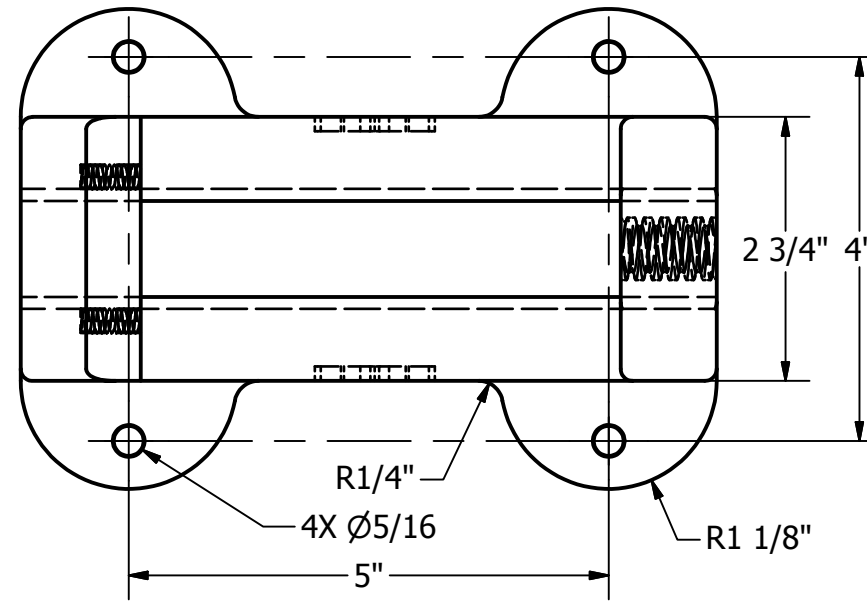
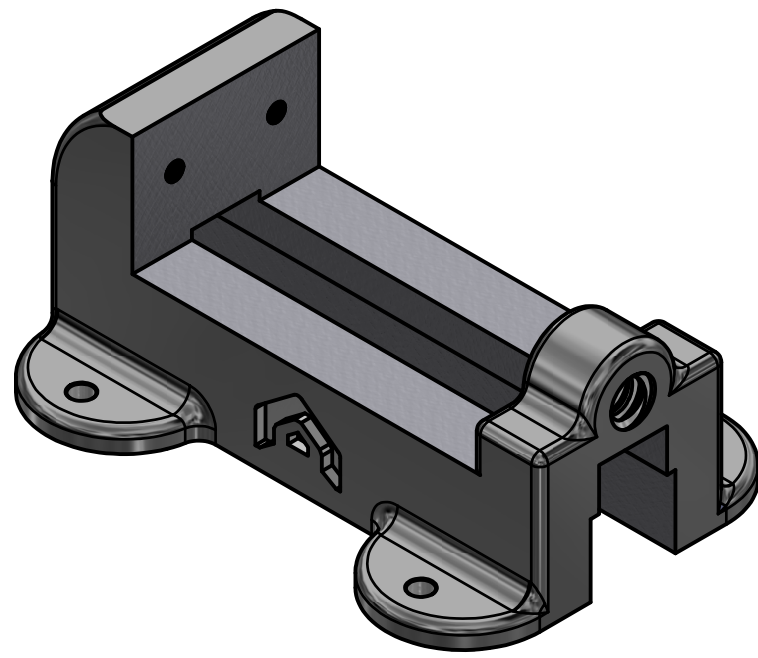

PARTS LIST		
ITEM	QTY	PART NUMBER
1	1	BASE
7	1	HANDLE ROD
9	2	SLIDE KEY

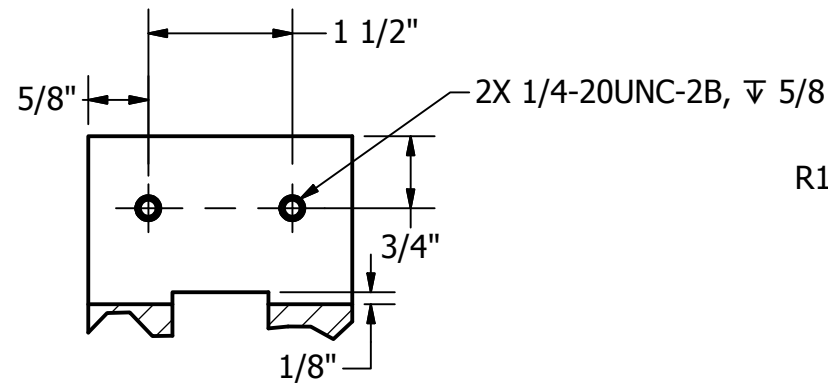
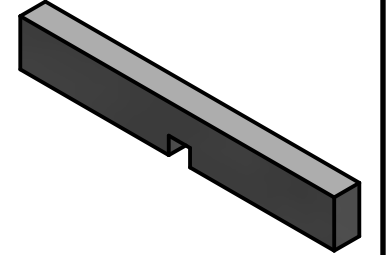
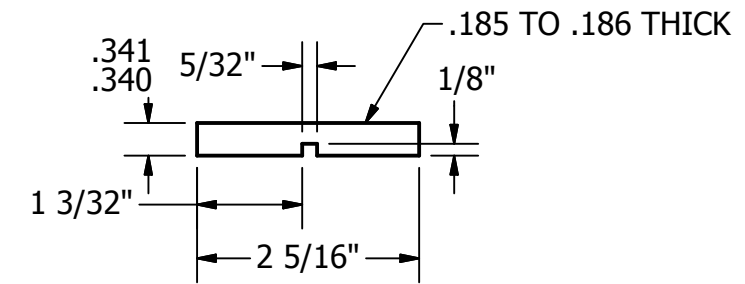

SECTION D-D  
SCALE 1 / 2

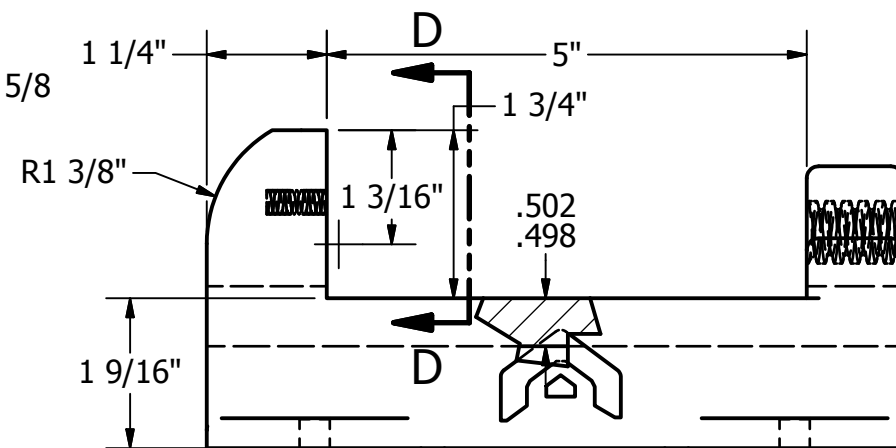

BASE  
SCALE 1 / 2

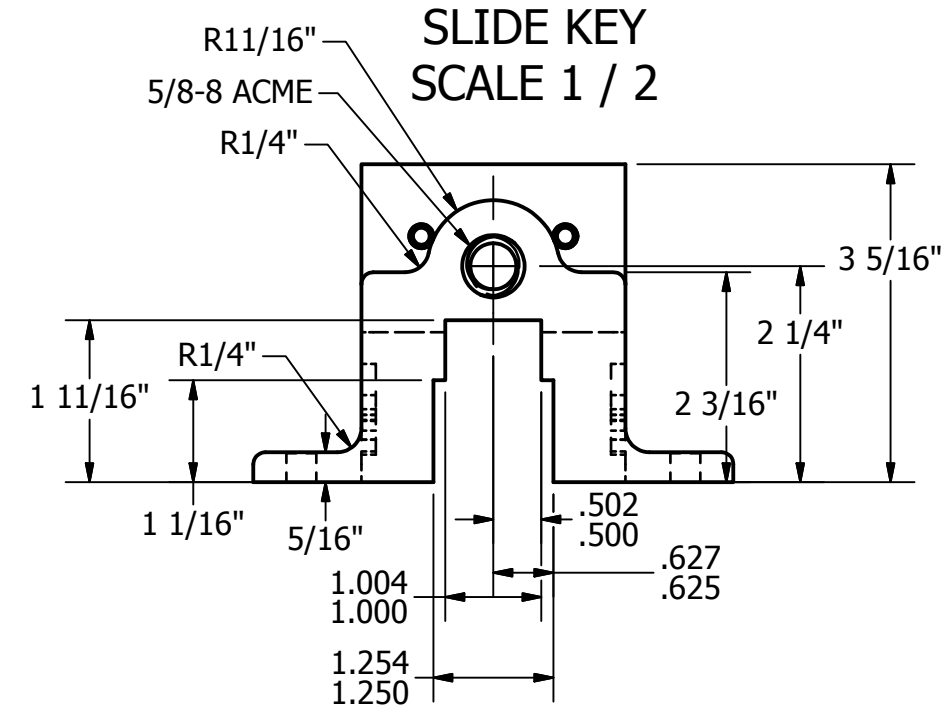

SLIDE KEY  
SCALE 1 / 2

**LEGEND:**

- Ø DIAMETER
- R RADIUS
- ° DEGREES
- COUNTERBORE
- ∇ DEPTH
- ✓ COUNTERSINK

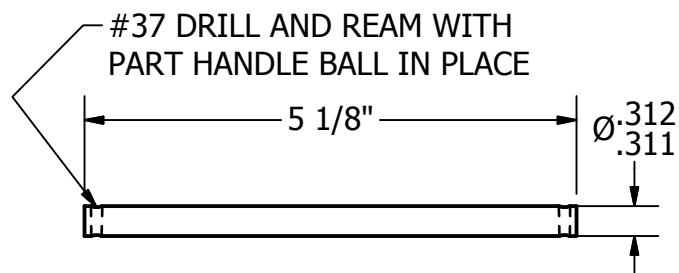

HANDLE ROD  
SCALE 1 / 2



DIGITAL DESIGN  
GRAPHICS  
TECHNOLOGY

WWW.DDGT.NET



JAYRACHEL92@GMAIL.COM  
DDGT.NET/STUDENTPAGES/JRACHEL

JUSTIN RACHEL  
ARCHITECTURAL DESIGN  
SOLAR SURVEYING

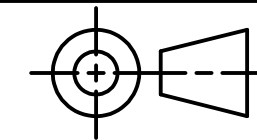

TOLERANCES UNLESS SPECIFIED:  
DECIMAL INCHES  
X = ±.020  
XX = ±.010  
XXX = ±.005  
FRACTIONAL ±1/64"  
ANGLES ±1 DEGREE  
SURFACES 32 ✓

COURSE: DDGT 240

INVENTOR DRAWING NAME:  
MACHINE VISE

FIG #: 14-71

DRAFTER: J. RACHEL

DATE: 10/15/2018

SCALE: AS NOTED

PAGE #: 3 OF 3