

MACHINE VISE EXPLODED
SCALE 1 / 2

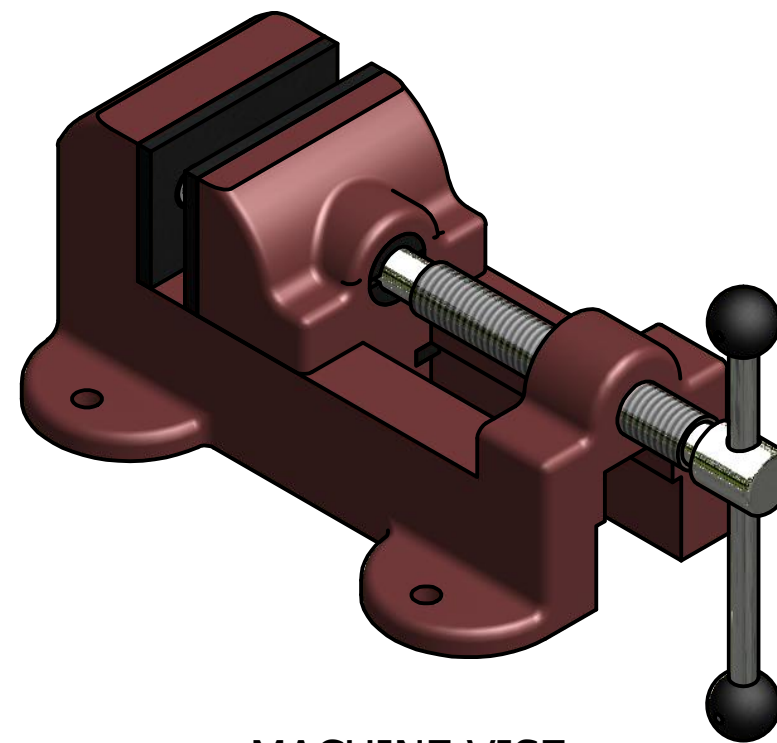

MACHINE VISE
SCALE 1 / 2

PARTS LIST				
ITEM	QTY	PART NUMBER	DESCRIPTION	MATERIAL
1	2	ANSI B18.6.3 - 1/4-20 UNC x 0.75	Cross Recessed 100° Flat Countersunk Head Machine Screw - Type IA - UNC - Inch	STEEL MILD
2	1	BASE		CAST IRON
3	2	JAW PLATE		CAST IRON
4	1	SPECIAL KEY		BRASS
5	1	SLIDING JAW		CAST IRON
6	2	SET SCREW		STEEL
7	1	WISE SCREW		STEEL
8	1	COLLAR		STEEL
9	2	SLIDE KEY		CAST IRON
10	2	ANSI B18.8.2 - No. 4/0 x 3/4	Pin - Taper	STEEL, MILD
11	2	HANDLE BALL		PLASTIC
12	1	HANDLE ROD		STEEL

DIGIATL DESIGN DRAFTING TECHNOLOGY	NAME:	J.VALADAO	DWG MACHINE VISE 14-17	DWG # 1 OF 5
	COURSE:	D.D.G.T		
	DATE:	1/24/2011		

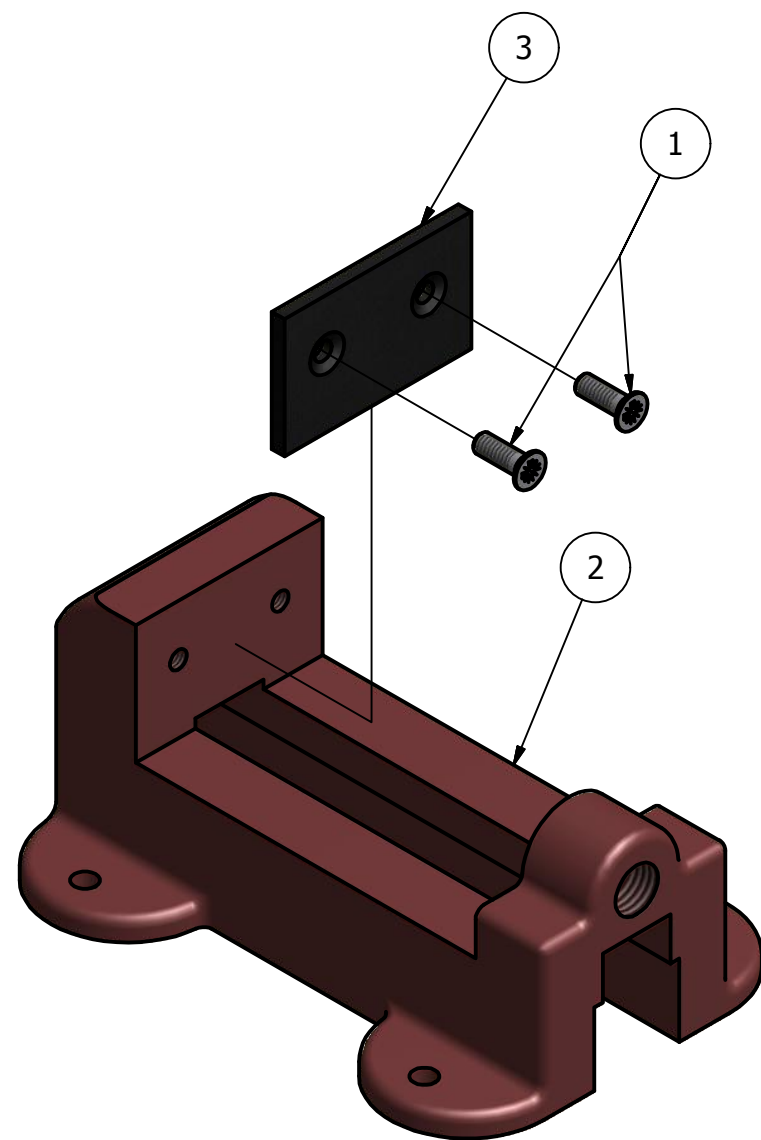

BASE EXPLODED
SCALE 1 / 2

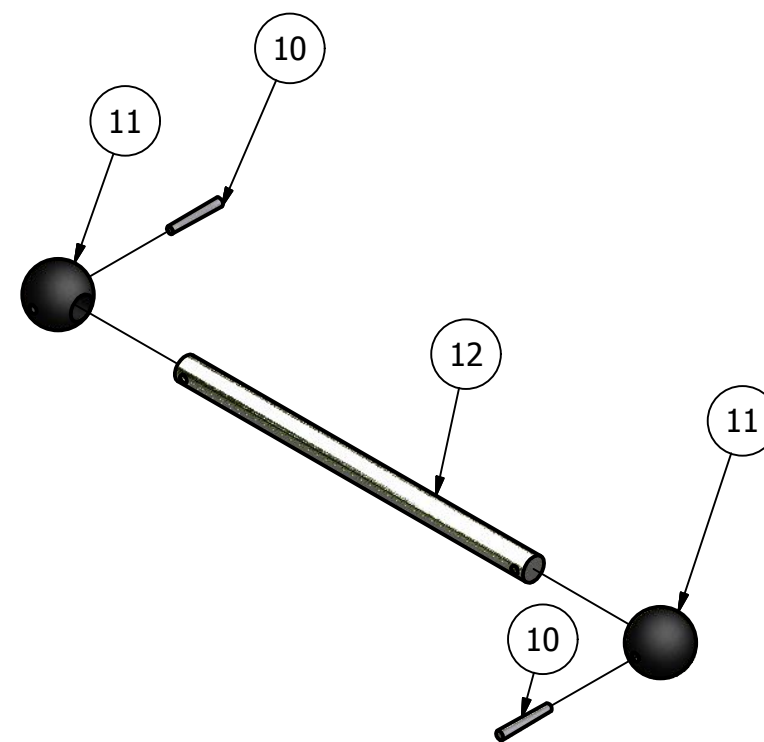

HANDEL EXPLODED
SCALE 1 / 2

PARTS LIST		
ITEM	QTY	PART NUMBER
1	2	ANSI B18.6.3 - 1/4-20 UNC x 0.75
2	1	BASE
3	2	JAW PLATE
10	2	ANSI B18.8.2 - No. 4/0 x 3/4
11	2	HANDLE BALL
12	1	HANDLE ROD

DIGIATL DESIGN DRAFTING TECHNOLOGY	NAME:	J.VALADAO	DWG MACHINE VISE 14-17	DWG # 2 OF 5
	COURSE:	D.D.G.T		
	DATE:	1/20/2011		

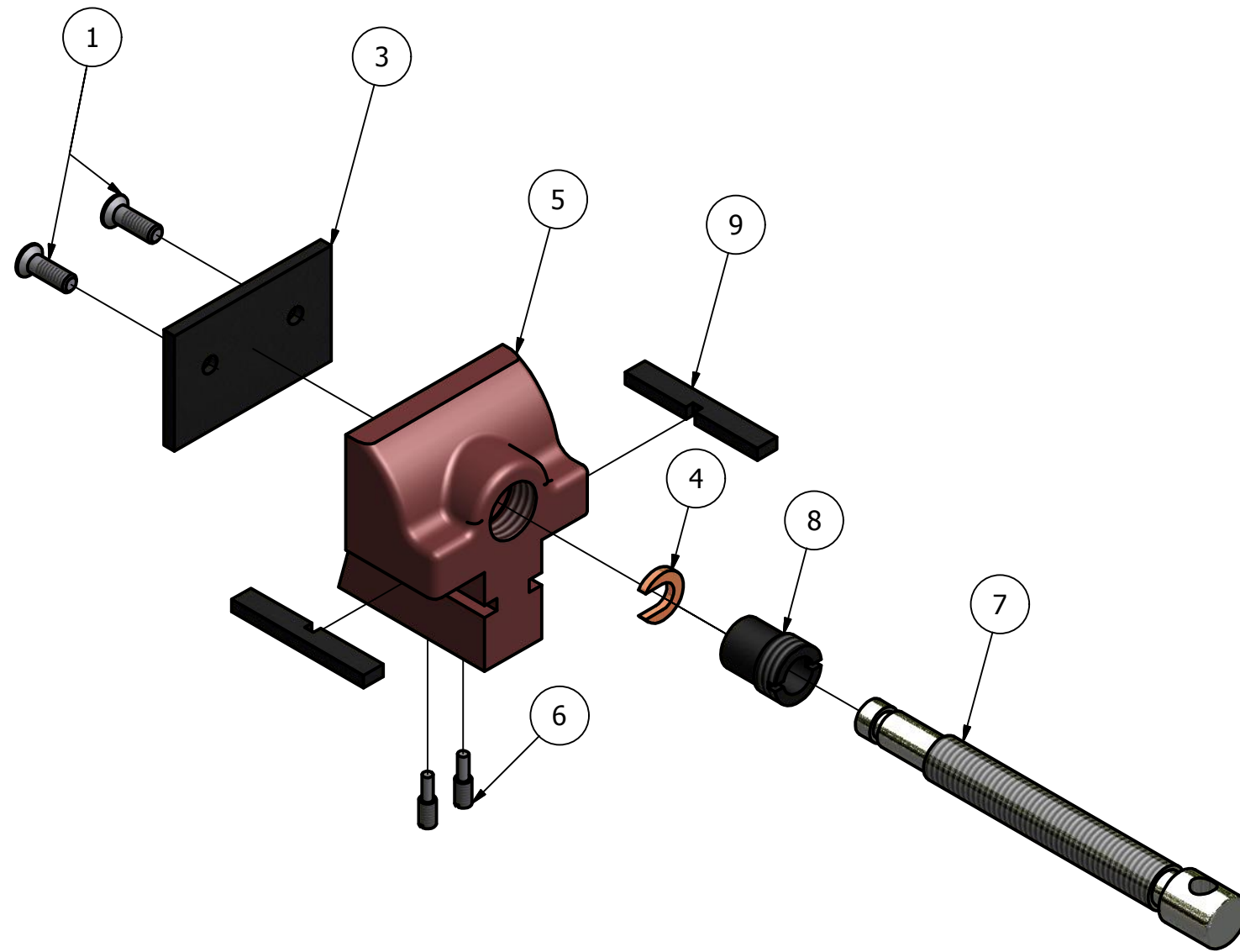

PARTS LIST		
ITEM	QTY	PART NUMBER
1	2	ANSI B18.6.3 - 1/4-20 UNC x 0.75
3	2	JAW PLATE
4	1	SPECIAL KEY
5	1	SLIDING JAW
6	2	SET SCREW
7	1	WISE SCREW
8	1	COLLAR
9	2	SLIDE KEY

SLIDING JAW EXPLODED
SCALE 1 / 2

DIGIATL DESIGN DRAFTING TECHNOLOGY	NAME: J.VALADAO	DWG MACHINE VISE 14-17	DWG # 3 OF 5
	COURSE: D.D.G.T		
	DATE: 1/20/2011		

PARTS LIST		
ITEM	QTY	PART NUMBER
2	1	BASE
3	2	JAW PLATE
9	2	SLIDE KEY
11	2	HANDLE BALL
12	1	HANDLE ROD

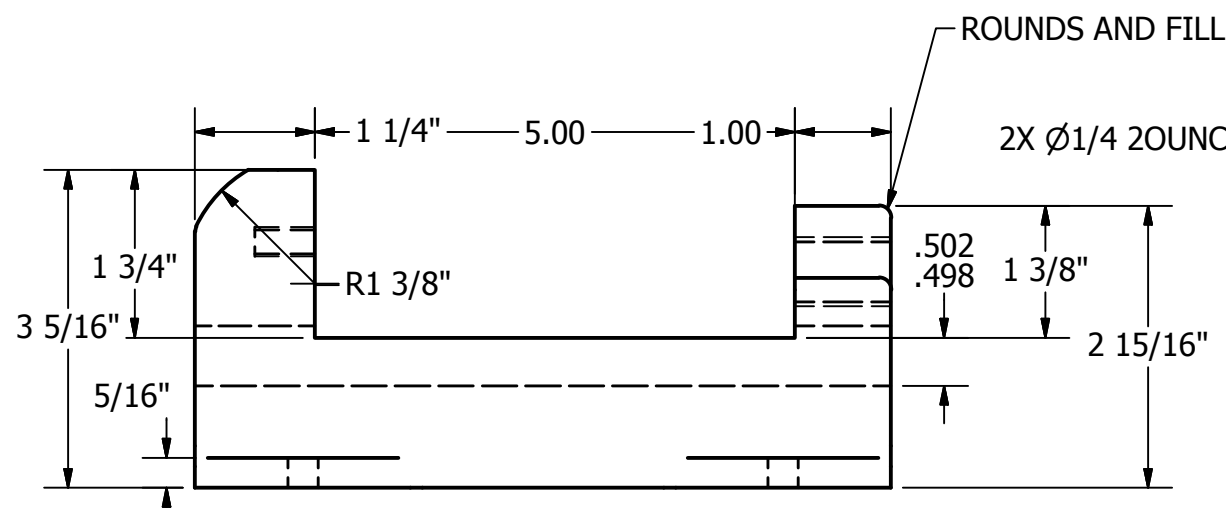
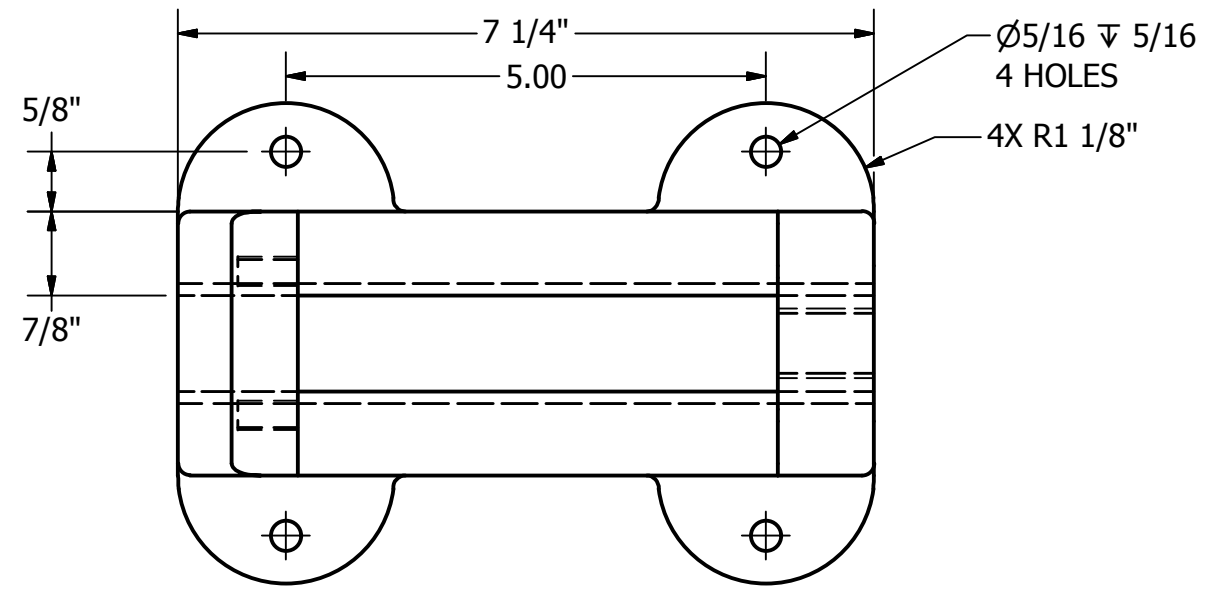

BASE
SCALE 1 / 2

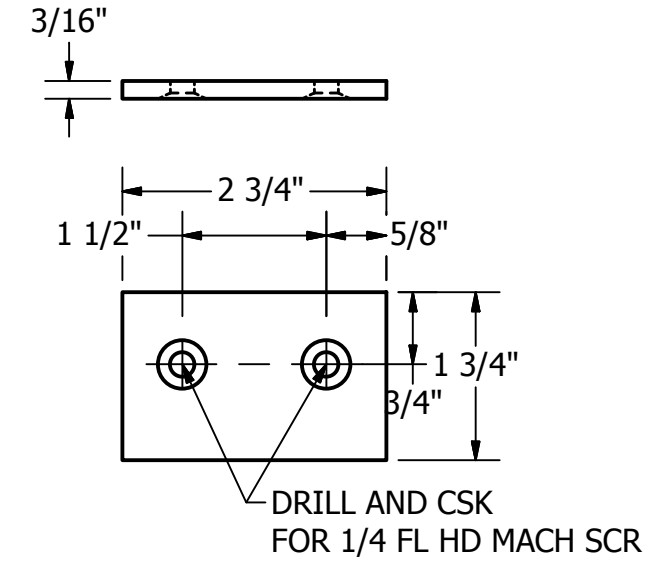
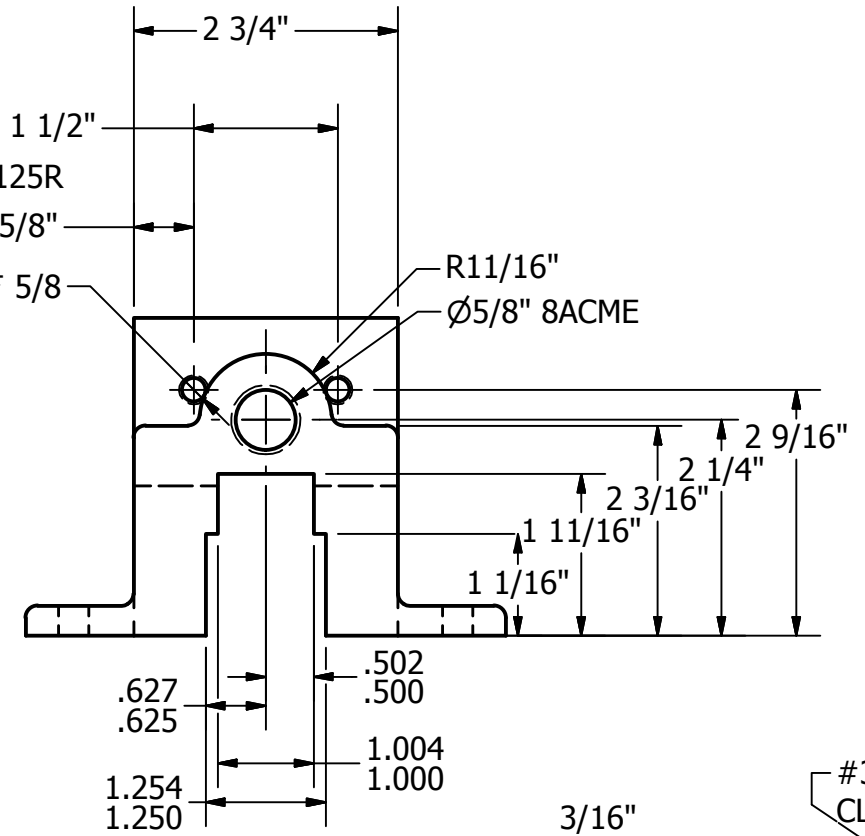

JAW PLATE
SCALE 1 / 2

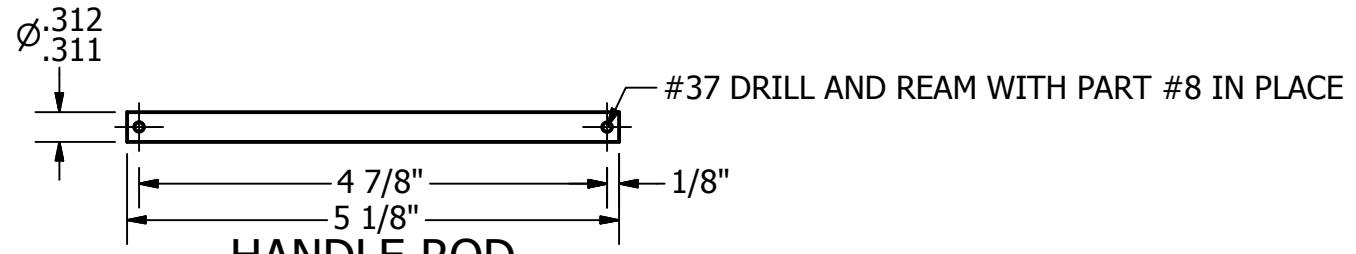

HANDLE ROD
SCALE 1 / 2

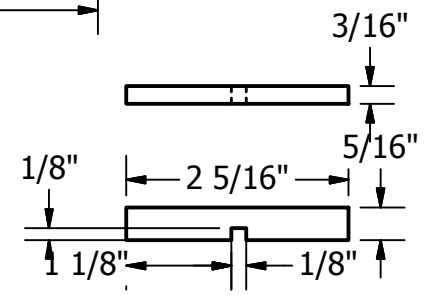

SLIDE KEY
SCALE 1 / 2

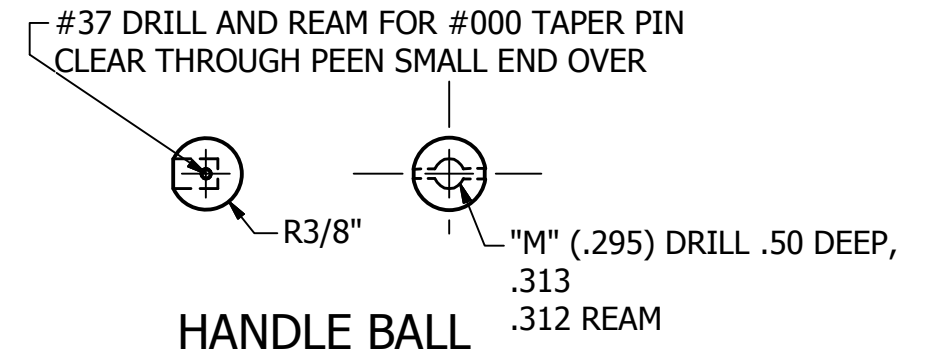

HANDLE BALL
SCALE 1 / 2

DIGIATL DESIGN DRAFTING TECHNOLOGY	NAME: J.VALADAO	DWG MACHINE VISE 14-17	DWG #
	COURSE: D.D.G.T		4 OF 5
	DATE: 1/19/2011		

PARTS LIST		
ITEM	QTY	PART NUMBER
4	1	SPECIAL KEY
5	1	SLIDING JAW
7	1	WISE SCREW
8	1	COLLAR

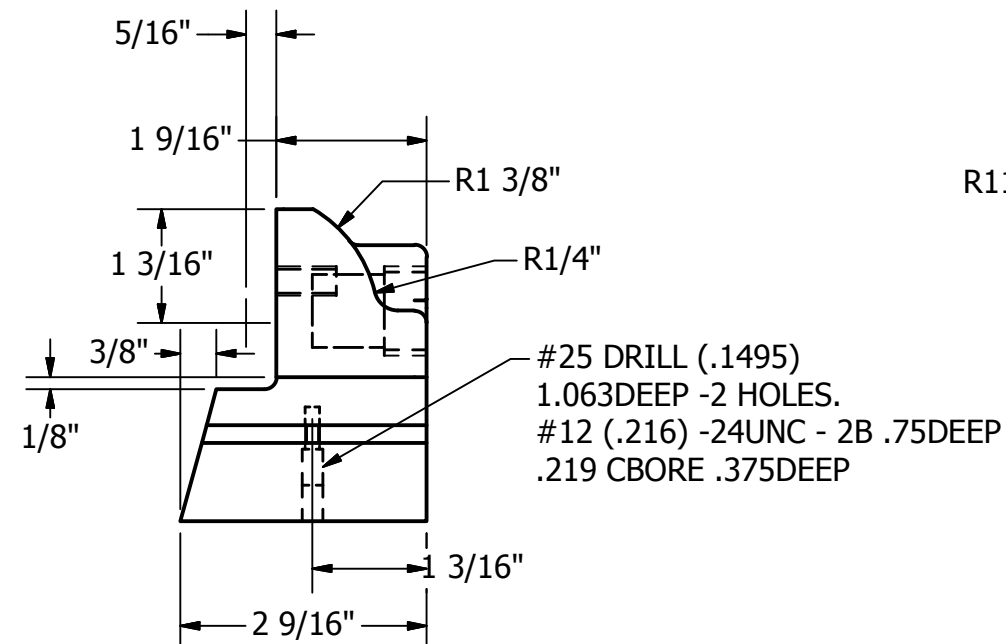
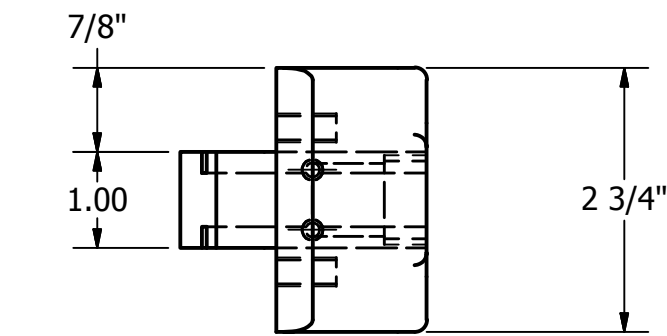

SLIDING JAW
SCALE 1 / 2

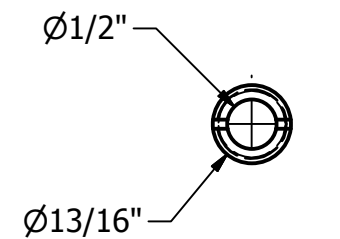
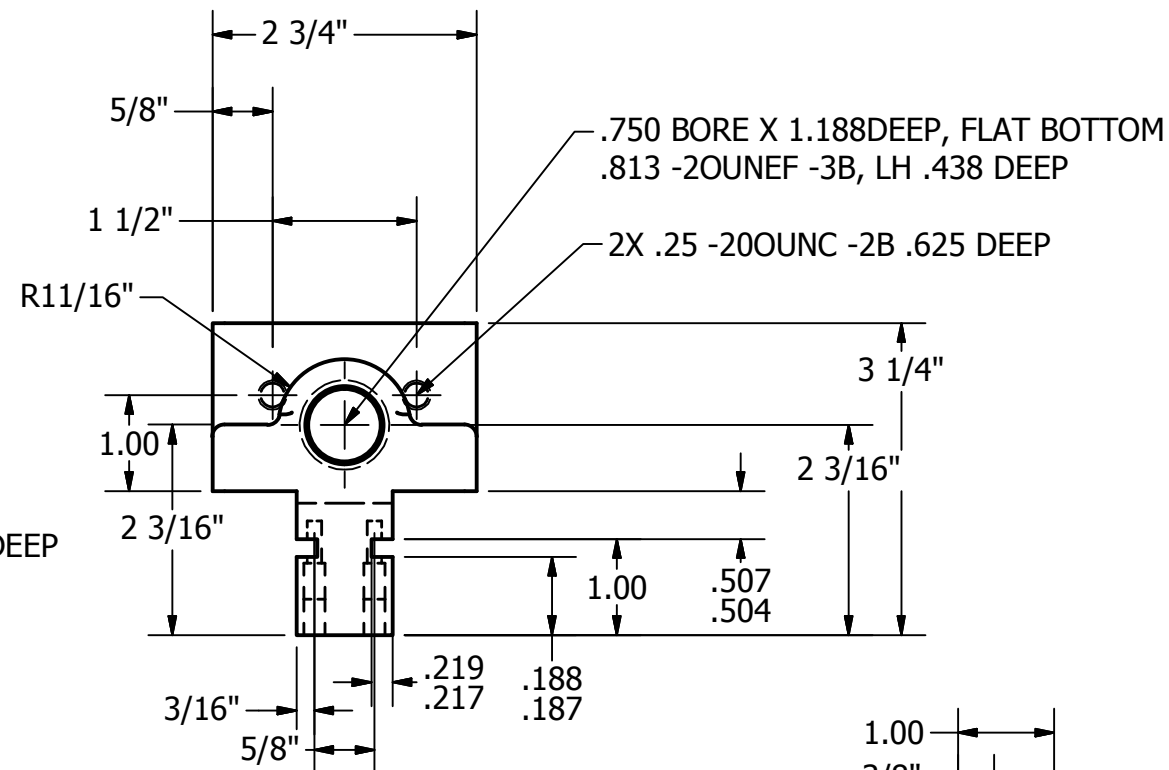

COLLAR
SCALE 1 / 2

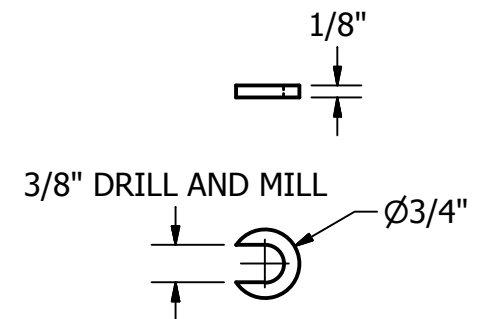
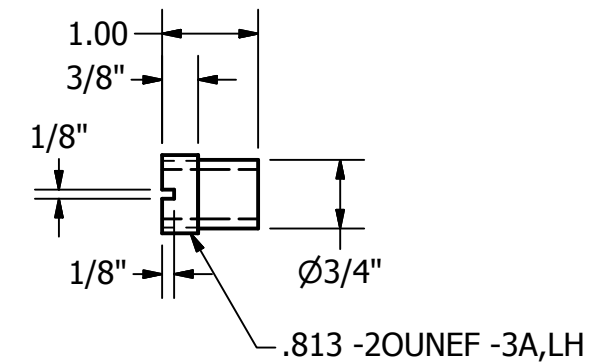

SPECIAL KEY
SCALE 1 / 2

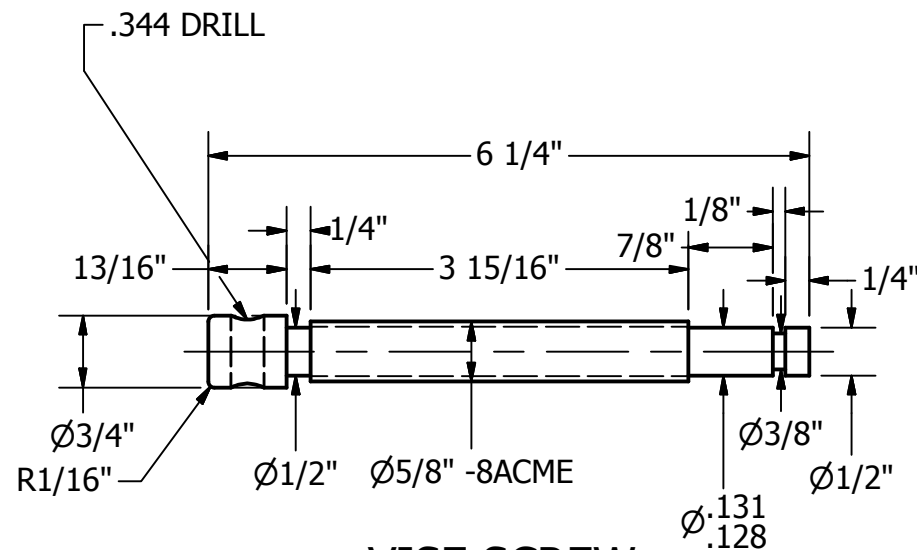

WISE SCREW
SCALE 1 / 2

DIGIATL DESIGN DRAFTING TECHNOLOGY	NAME:	J.VALADAO	DWG	DWG #
	COURSE:	D.D.G.T	MACHINE VISE 14-17	5 OF 5
	DATE:	1/20/2011		