

ROBOTIC ARM EXPLODED ASSEMBLY
SCALE 1 / 2

GENERAL NOTES:
 ALL FILLETS ARE .06in UNLESS OTHERWISE SPECIFIED
 ALL CHAMFERS ARE .02 X 45° UNLESS OTHERWISE SPECIFIED

PARTS LIST				
ITEM	QTY	PART NUMBER	MATERIAL	DESCRIPTION
1	1	BASE E-01	ALUMINUM	
2	1	ARM E-01	ALUMINUM	
3	1	ARM E-02	ALUMINUM	
4	1	BASE CAP	ALUMINUM	
5	1	ELBOW CAP	ALUMINUM	
6	1	SLIDING TUBE	STEEL	
7	1	SLIDING TUBE TOP	STEEL	
8	1	VACUUM CUP	RUBBER	
9	1	VACUUM CAP	ALUMINUM	
10	1	VACUUM CONNECTOR	STEEL	
11	3	10-36 UNS CAP SCREW	STEEL	
12	1	VACUUM TUBE	RUBBER	INNER Ø.13 OUTER Ø.25 Length 10

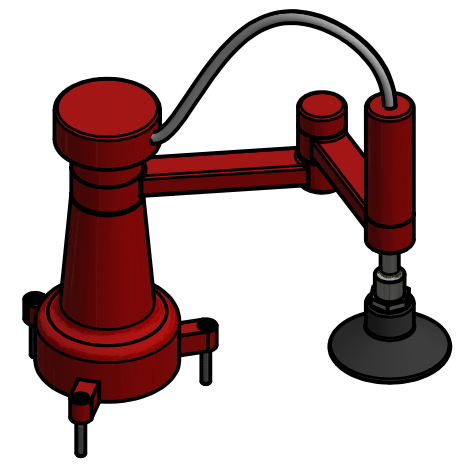

ROBTIC ARM ASSEMBLY
SCALE 1 / 4

LEGEND:
 Ø DIAMETER
 R RADIUS
 ° DEGREES
 ▽ DEPTH
 □ COUNTERBORE



DIGITAL DESIGN
 GRAPHICS
 TECHNOLOGY

WWW.DDGT.NET

JOSEPH WILLIAMS



(707)673-6354
 JWILLIAMSASD@GMAIL.COM
 WWW.DDGT.NET/STUDENTPAGES/JWILLIAMS

GRAPHIC DESIGNER

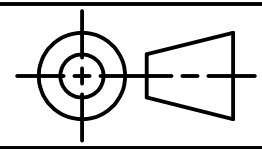

TOLERANCES UNLESS SPECIFIED:
 DECIMAL INCHES:
 X = ±.020
 XX = ±.010
 XXX = ±.005
 FRACTIONAL ±1/64"
 ANGLES ±1 DEGREE
 SURFACES 32 ✓

COURSE:	DDGT240
INVENTOR DRAWING NAME:	ROBOTIC ARM
FIG #:	10-58
DRAFTER:	J.WILLIAMS
DATE:	2/20/2020
SCALE:	AS NOTED
PAGE #:	1 OF 4

PARTS LIST		
ITEM	QTY	PART NUMBER
1	1	BASE E-01
2	1	ARM E-01
3	1	ARM E-02
4	1	BASE CAP
7	1	SLIDING TUBE TOP

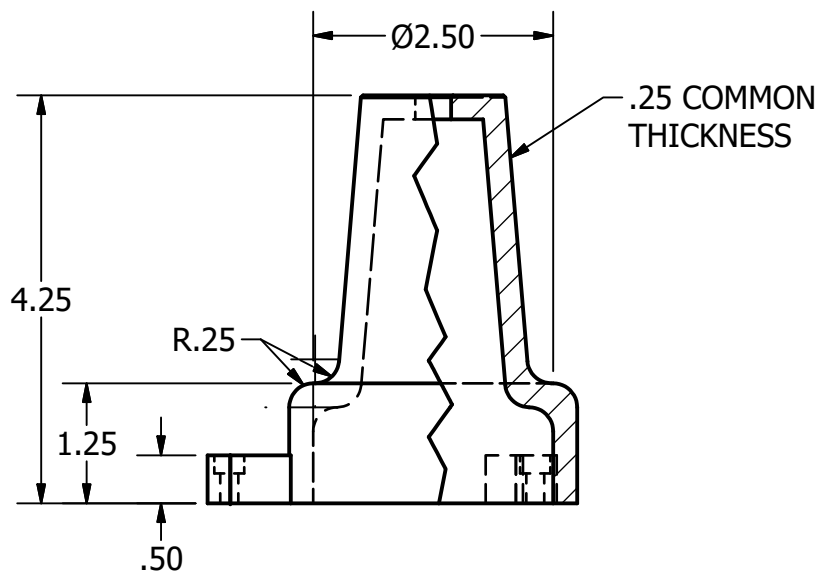
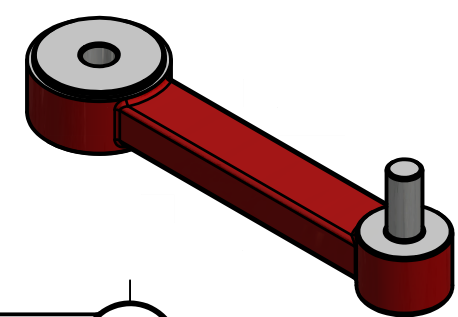
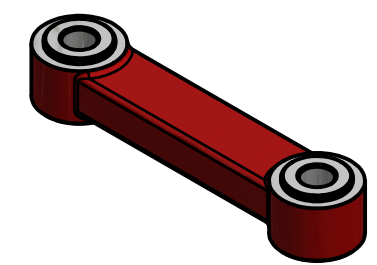
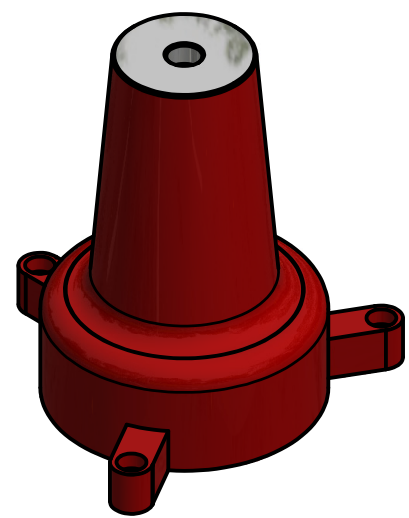
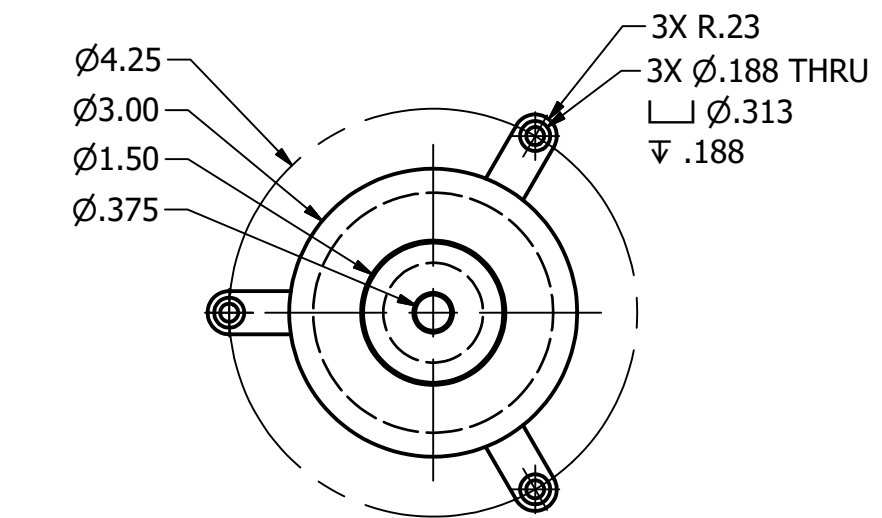

BASE E-01
SCALE 1 / 2

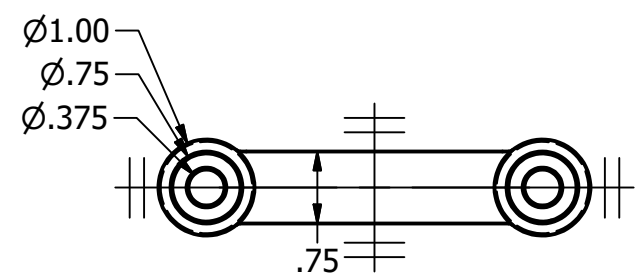

ARM E-02
SCALE 1 / 2

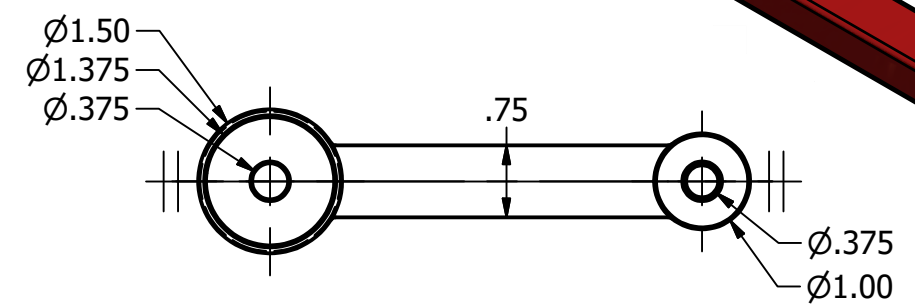

ARM E-01
SCALE 1 / 2

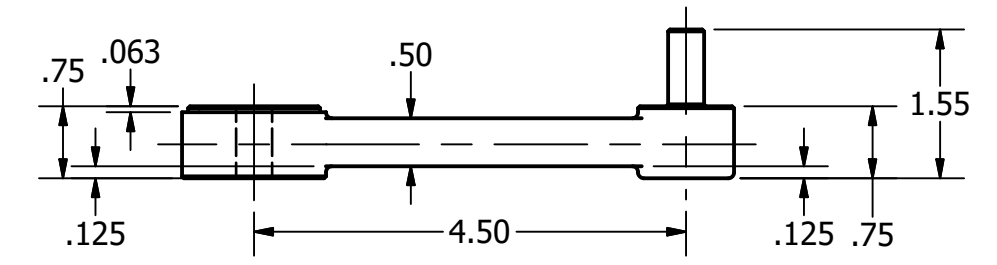
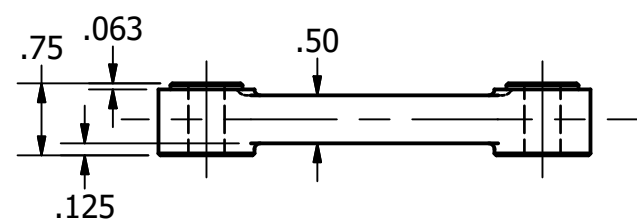

LEGEND:

- Ø DIAMETER
- R RADIUS
- ° DEGREES
- ∇ DEPTH
- COUNTERBORE

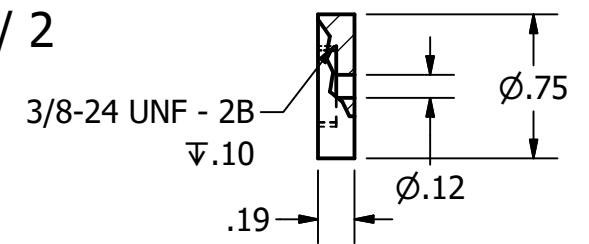

SLIDING TUBE TOP
SCALE 1 : 1

GENERAL NOTES:
 ALL FILLETS ARE .06in UNLESS OTHERWISE SPECIFIED
 ALL CHAMFERS ARE .02 X 45° UNLESS OTHERWISE SPECIFIED

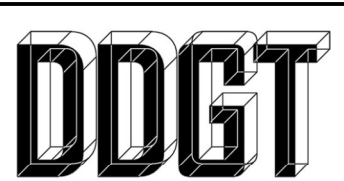

DIGITAL DESIGN
 GRAPHICS
 TECHNOLOGY

WWW.DDGT.NET

JOSEPH WILLIAMS



(707)673-6354
 JWILLIAMSASD@GMAIL.COM
 WWW.DDGT.NET/STUDENTPAGES/JWILLIAMS

GRAPHIC DESIGNER

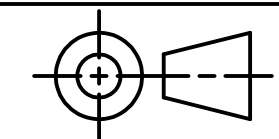

TOLERANCES UNLESS SPECIFIED:
 DECIMAL INCHES:
 X = ±.020
 XX = ±.010
 XXX = ±.005
 FRACTIONAL ±1/64"
 ANGLES ±1 DEGREE
 SURFACES 32 ✓

COURSE:	DDGT240
INVENTOR DRAWING NAME:	ROBOTIC ARM
FIG #:	10-58
DRAFTER:	J.WILLIAMS
DATE:	2/20/2020
SCALE:	AS NOTED
PAGE #:	2 OF 4

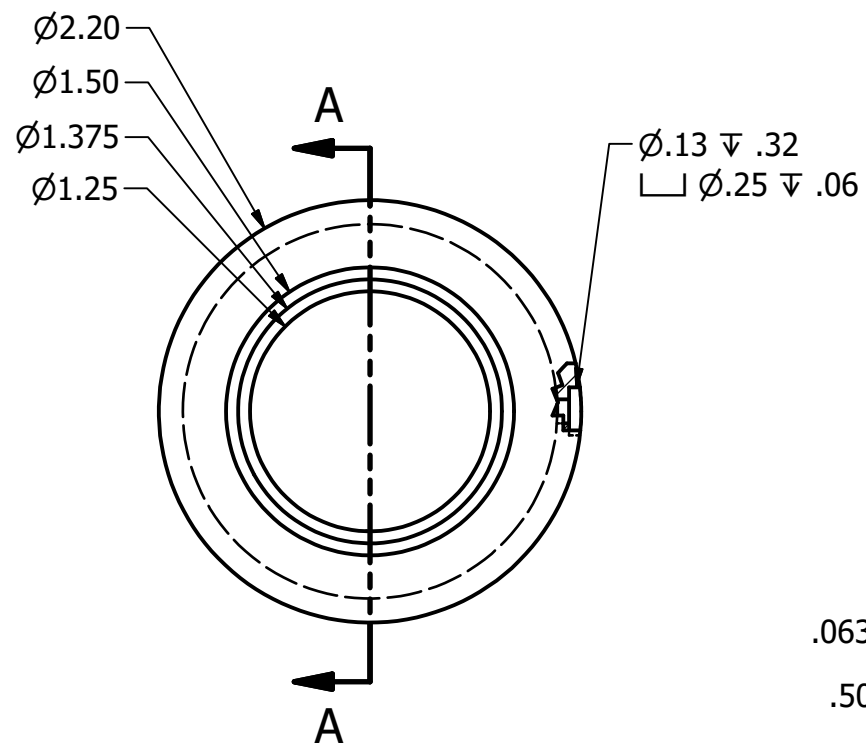

BASE CAP
SCALE 1 : 1

$\varnothing .13 \nabla .32$
 $\sqsupset \varnothing .25 \nabla .06$

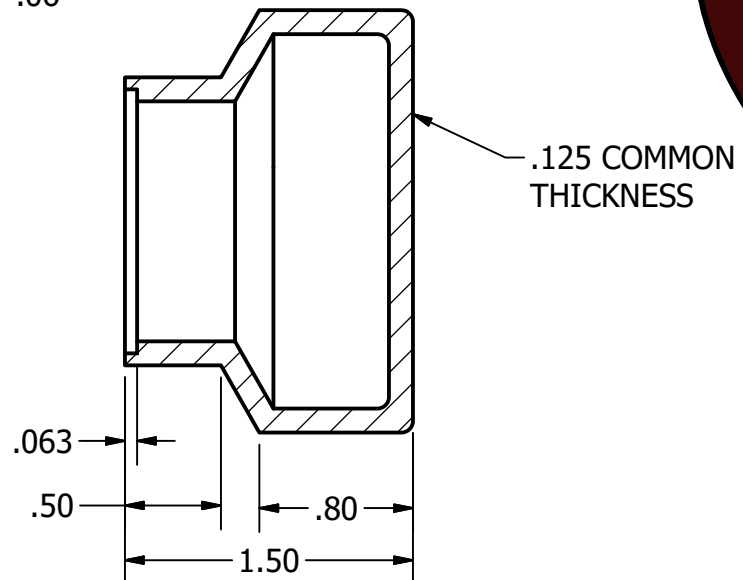

SECTION A-A
SCALE 1 : 1

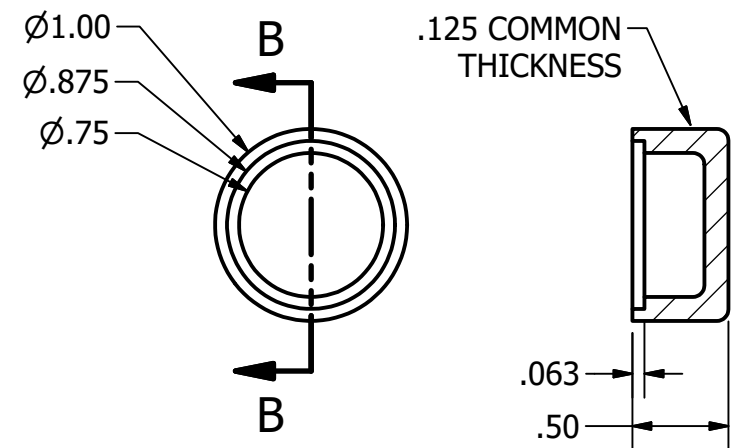
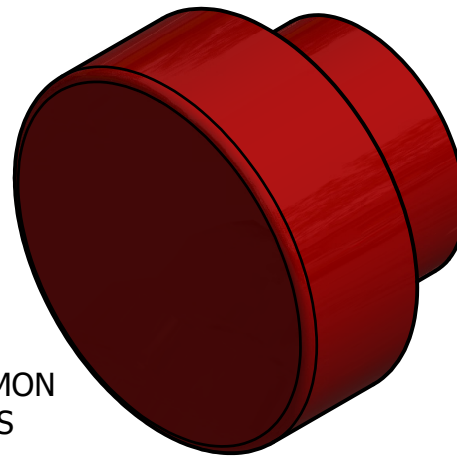

ELBOW CAP
SCALE 1 : 1

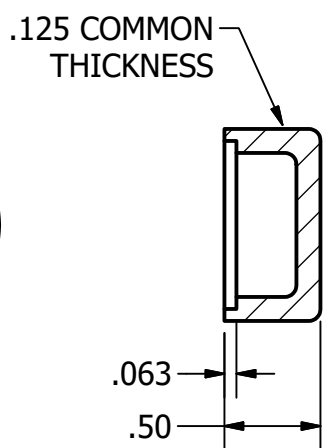

SECTION B-B
SCALE 1 : 1

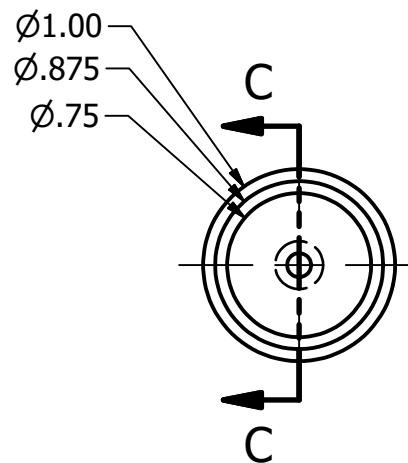
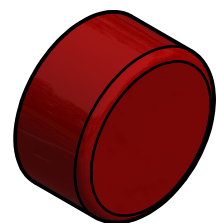

VACUUM CAP
SCALE 1 : 1

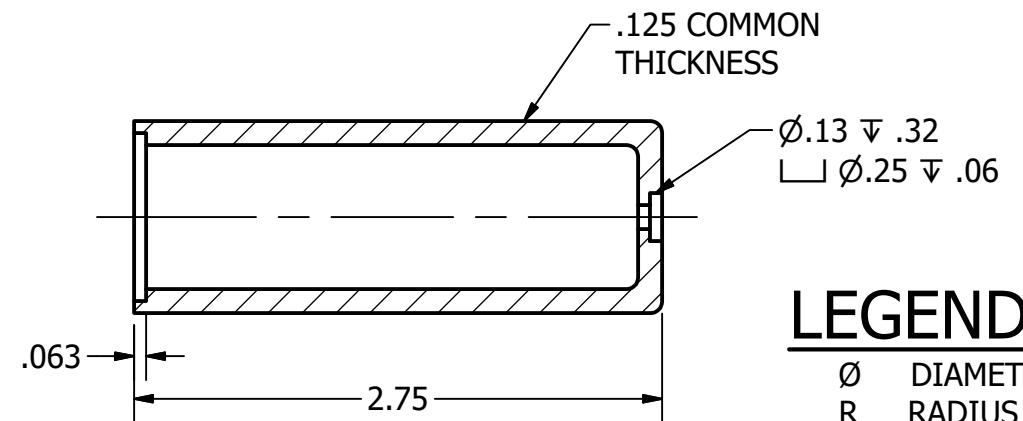

SECTION C-C
SCALE 1 : 1

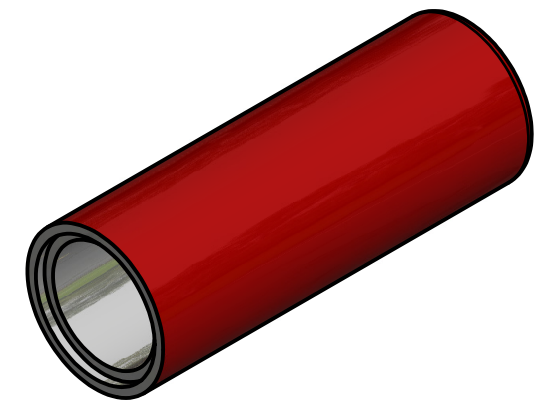

PARTS LIST		
ITEM	QTY	PART NUMBER
4	1	BASE CAP
5	1	ELBOW CAP
6	1	SLIDING TUBE
8	1	VACUUM CUP
9	1	VACUUM CAP
10	1	VACUUM CONNECTOR

LEGEND:

- \varnothing DIAMETER
- R RADIUS
- $^{\circ}$ DEGREES
- ∇ DEPTH
- \sqsupset COUNTERBORE

GENERAL NOTES:

ALL FILLETS ARE .06in UNLESS OTHERWISE SPECIFIED
 ALL CHAMFERS ARE .02 X 45° UNLESS OTHERWISE SPECIFIED



DIGITAL DESIGN
 GRAPHICS
 TECHNOLOGY

WWW.DDGT.NET

JOSEPH WILLIAMS



(707)673-6354

JOWILLIAMSASD@GMAIL.COM

WWW.DDGT.NET/STUDENTPAGES/JWILLIAMS

GRAPHIC DESIGNER

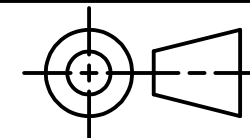

TOLERANCES UNLESS SPECIFIED:
 DECIMAL INCHES:
 X = ±.020
 XX = ±.010
 XXX = ±.005
 FRACTIONAL ±1/64"
 ANGLES ±1 DEGREE

SURFACES \checkmark 32

COURSE: DDGT240

INVENTOR DRAWING NAME:
 ROBOTIC ARM

FIG #: 10-58

DRAFTER: J.WILLIAMS

DATE: 2/20/2020

SCALE: AS NOTED

PAGE #: 3 OF 4

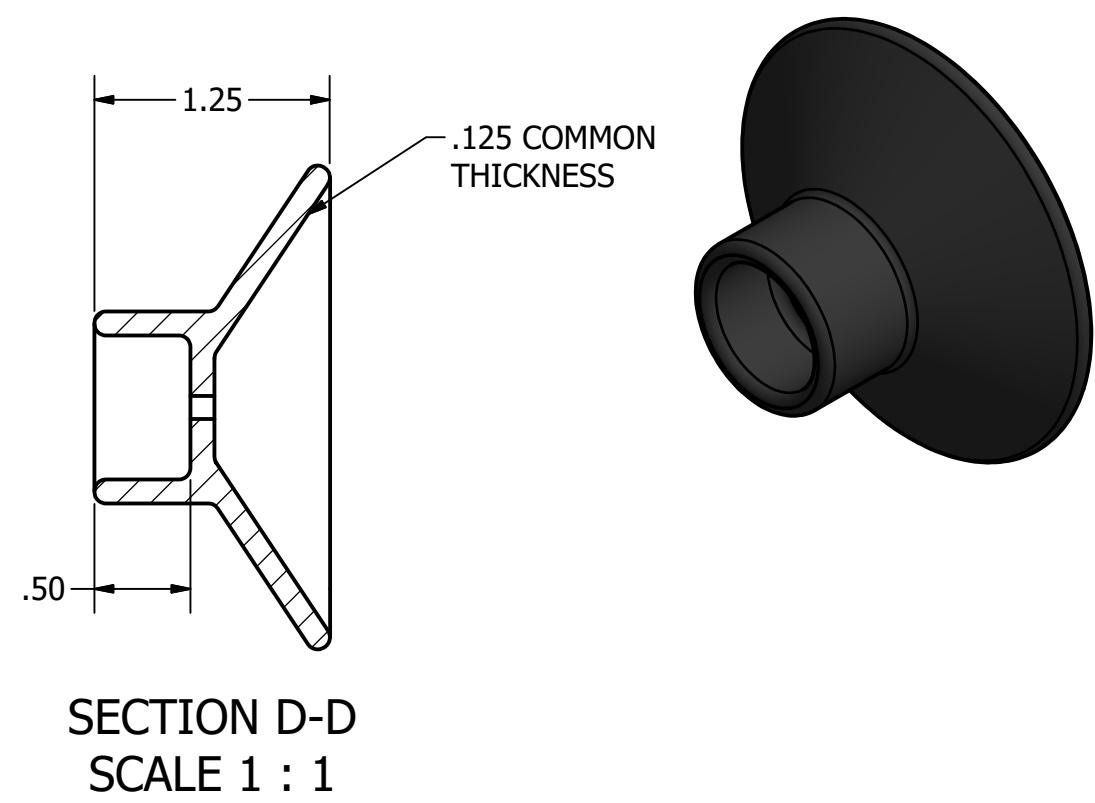
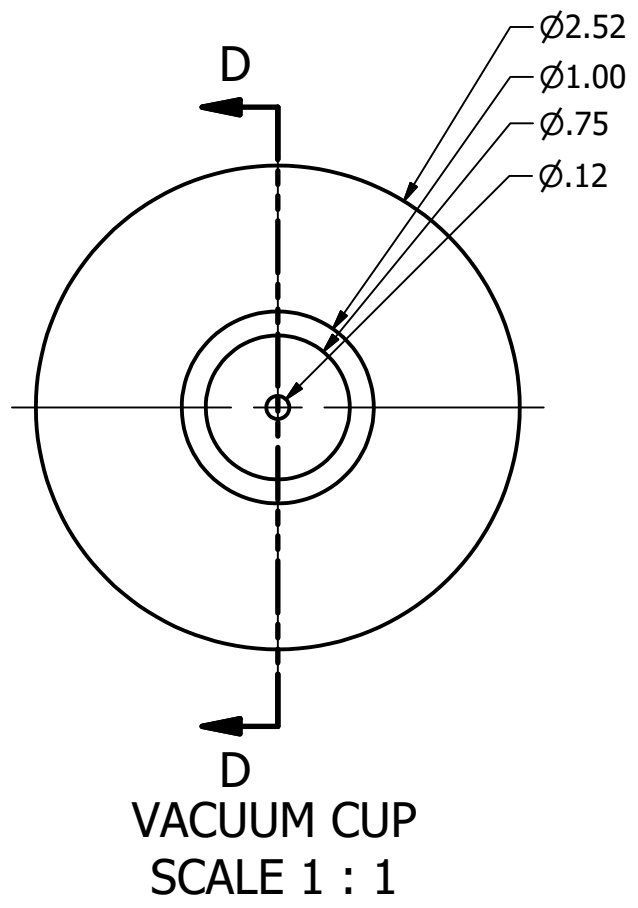

PARTS LIST		
ITEM	QTY	PART NUMBER
6	1	SLIDING TUBE
8	1	VACUUM CUP
10	1	VACUUM CONNECTOR

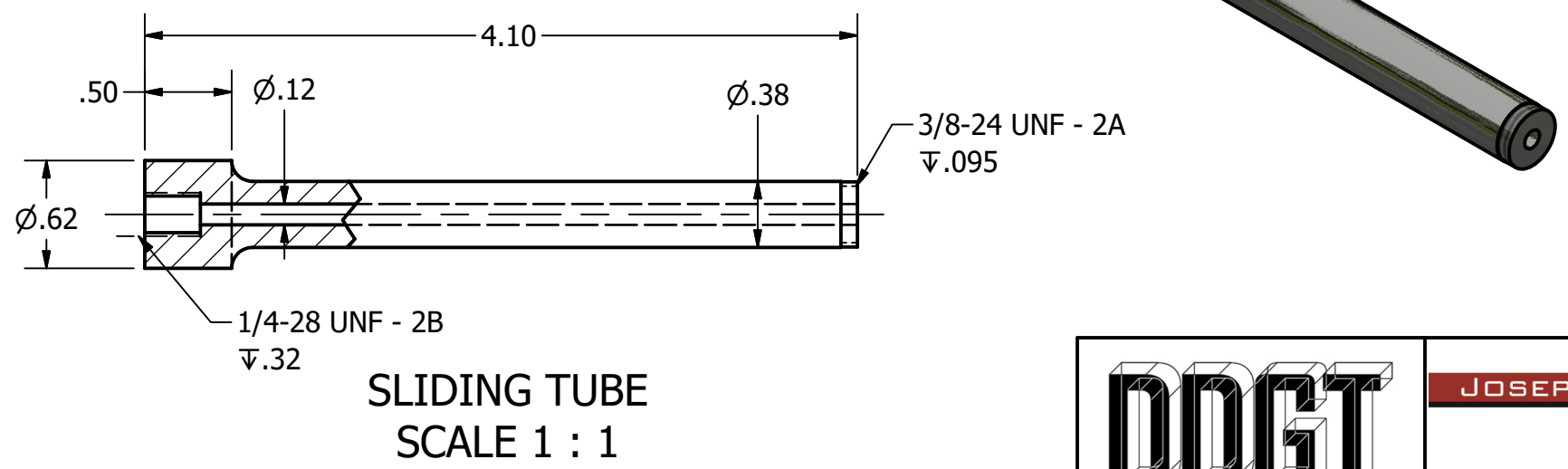
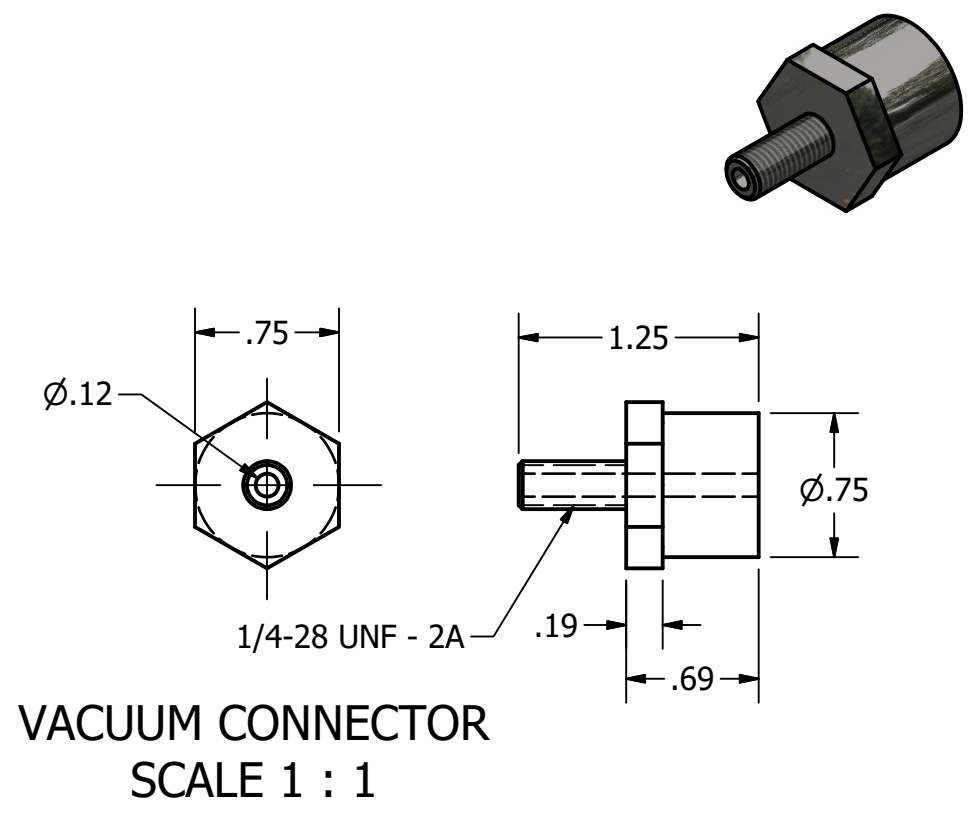

LEGEND:

- \varnothing DIAMETER
- R RADIUS
- $^\circ$ DEGREES
- ∇ DEPTH
- COUNTERBORE

GENERAL NOTES:
 ALL FILLETS ARE .06in UNLESS OTHERWISE SPECIFIED
 ALL CHAMFERS ARE .02 X 45° UNLESS OTHERWISE SPECIFIED

<p>DIGITAL DESIGN GRAPHICS TECHNOLOGY</p> <p>WWW.DDGT.NET</p>	<p>JOSEPH WILLIAMS</p> <p>(707)673-6354</p> <p>JOWILLIAMSASD@GMAIL.COM</p> <p>WWW.DDGT.NET/STUDENTPAGES/JWILLIAMS</p> <p>GRAPHIC DESIGNER</p>	<p>TOLERANCES UNLESS SPECIFIED: DECIMAL INCHES: X = $\pm .020$ XX = $\pm .010$ XXX = $\pm .005$ FRACTIONAL $\pm 1/64$" ANGLES ± 1 DEGREE SURFACES $\sqrt{32}$</p>	COURSE: DDGT240
			INVENTOR DRAWING NAME: ROBOTIC ARM
			FIG #: 10-58
			DRAFTER: J.WILLIAMS
			DATE: 2/20/2020
			SCALE: AS NOTED
			PAGE #: 4 OF 4