

PARTS LIST

ITEM	QTY	PART NUMBER	MATERIAL
1	1	DRILL PRESS BRACKET	STEEL

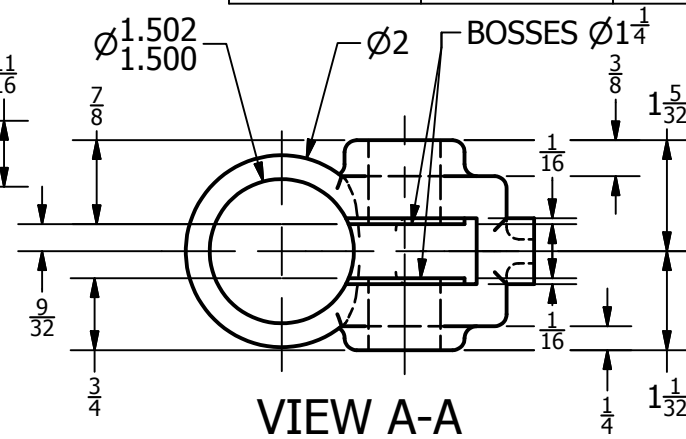

VIEW A-A
SCALE 1:2

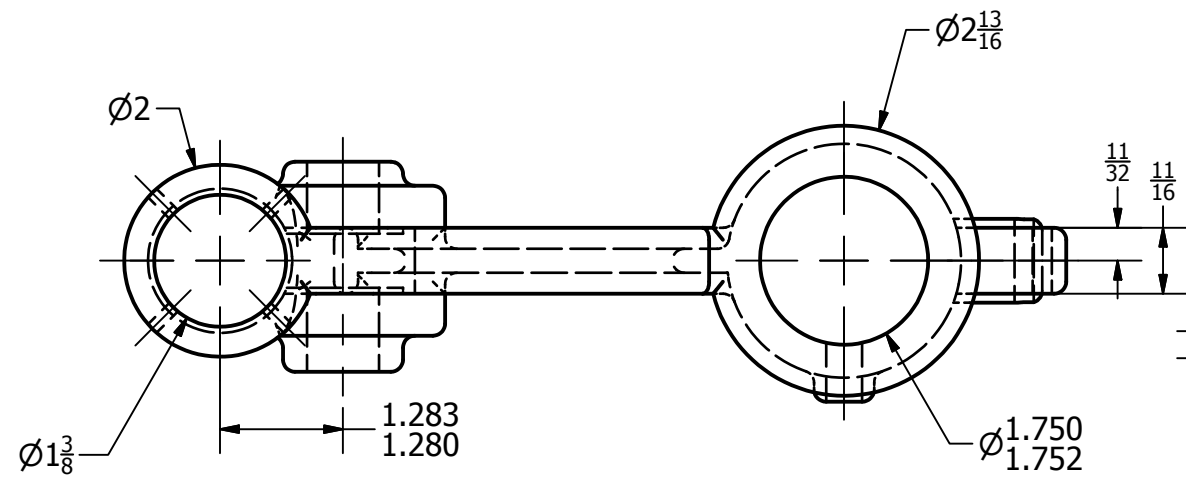
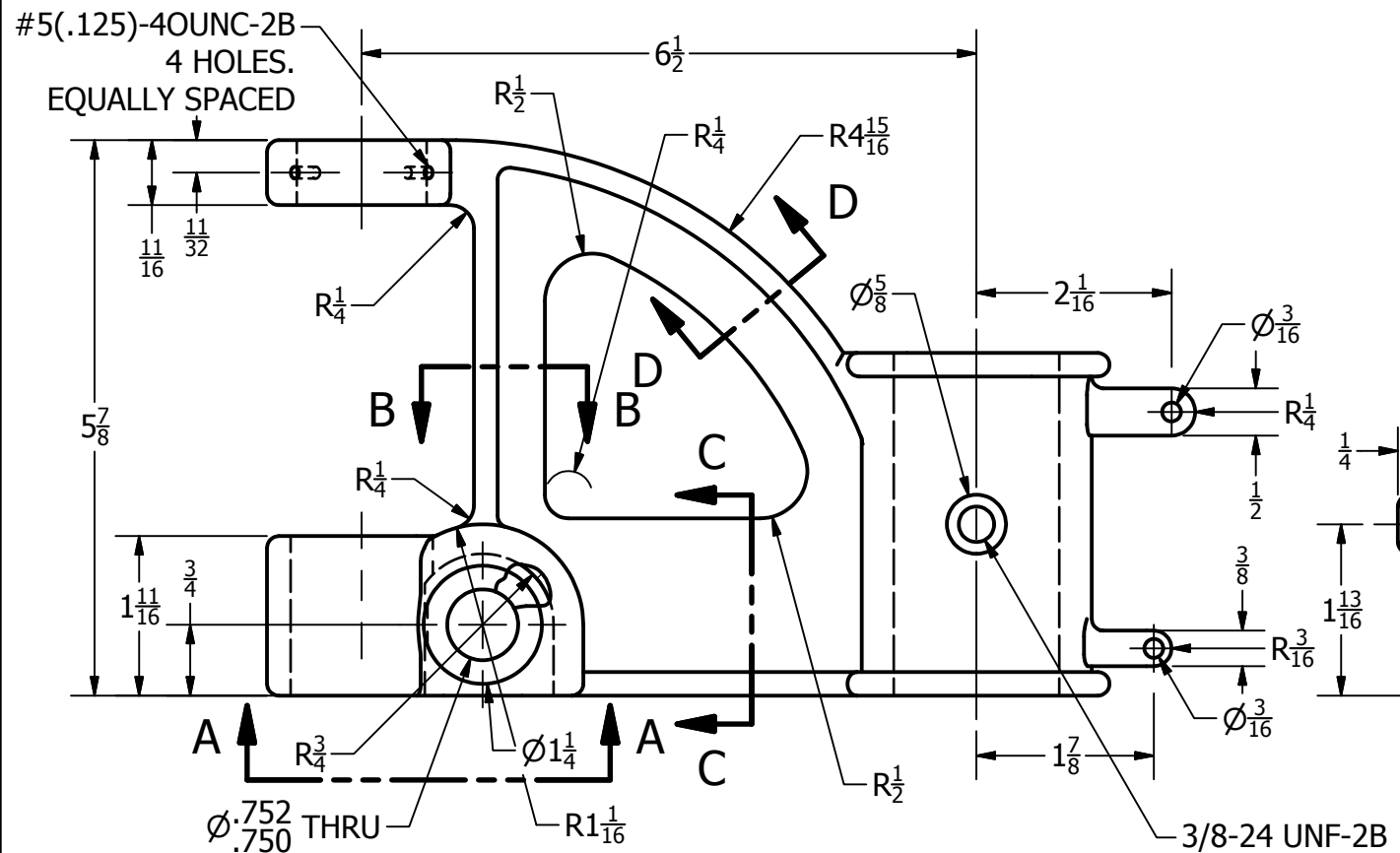
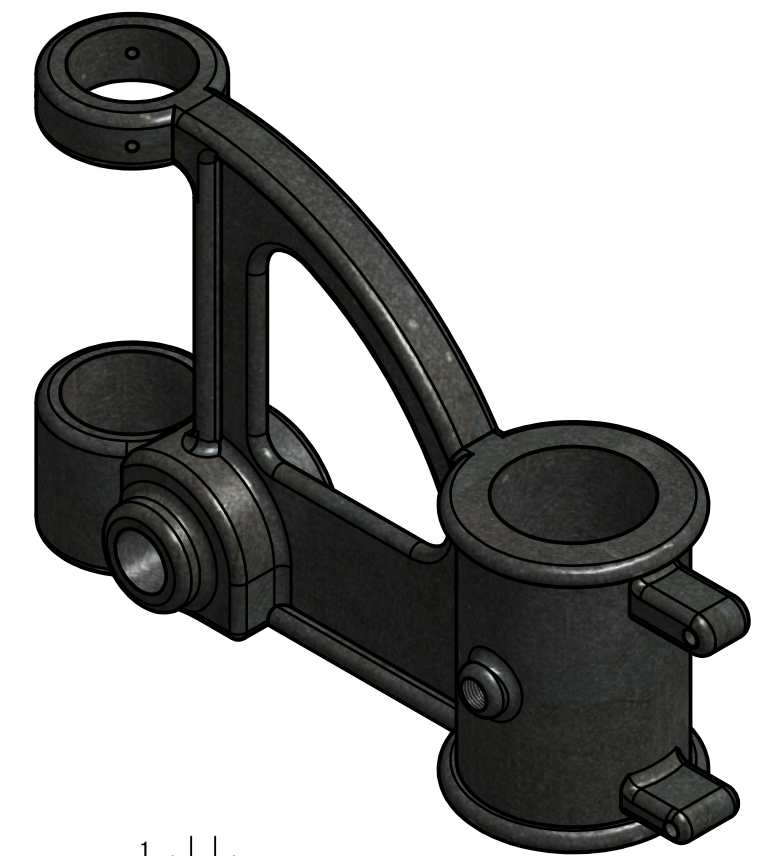

DRILL PRESS BRACKET
SCALE 1:2

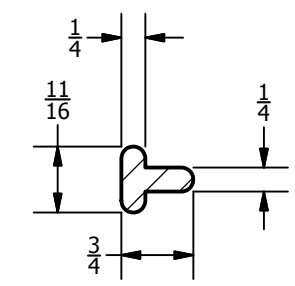

SECTION B-B
SCALE 1:2

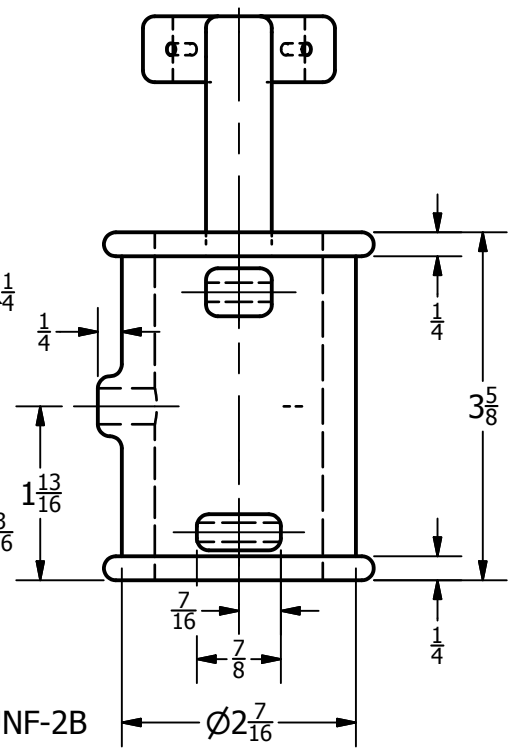

SECTION D-D
SCALE 1:2

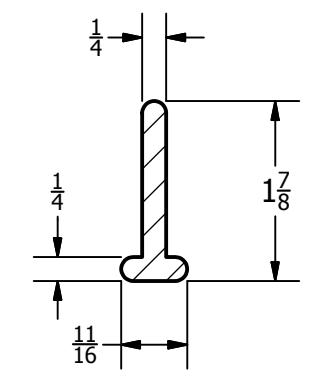

SECTION C-C
SCALE 1:2

LEGEND:

- ϕ DIAMETER
- R RADIUS
- $^\circ$ DEGREE

ALL ROUNDS AND FILLETS 1/8" UNLESS OTHERWISE NOTED



DIGITAL DESIGN
GRAPHICS
TECHNOLOGY

WWW.DDGT.NET



Leon Bacud
Technical Designer

- Email: leonbacud@outlook.com
- Phone: (707)653-6605
- Web: <http://www.leonbacud.com>
- LinkedIn: <http://linkedin.com/in/leonbacud>

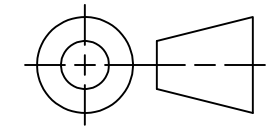

TOLERANCES UNLESS SPECIFIED:
DECIMAL INCHES:
X = $\pm .020$
XX = $\pm .010$
XXX = $\pm .005$
FRACTIONAL $\pm 1/64"$
ANGLES ± 1 DEGREE
SURFACES $\sqrt{32}$

COURSE:	DDGT 121
INVENTOR IDW NAME:	DRILL PRESS BRACKET
FIG NO:	14-35
DRAFTER:	L. BACUD
DATE:	5/11/2015
SCALE:	AS NOTED
PAGE NO:	1 OF 1