

TROLLEY EXPLODED ASSEMBLY  
SCALE 1:4

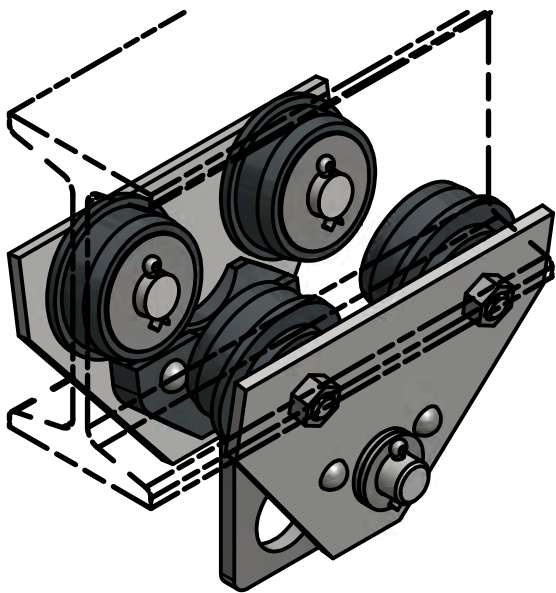

TROLLEY  
SCALE 1:4

PARTS LIST

ITEM	QTY	PART NUMBER	MATERIAL	DESCRIPTION
1	2	SIDE PLATE RIVITED		
1.1	1	SIDE PLATE	MILD STEEL	
1.2	1	GUIDE	CAST IRON	
1.3	2	RIVET	STAINLESS STEEL	BUTTON HEAD, Ø10 X 60 LG
2	1	AXLE	COLD-ROLLED STEEL	
3	1	HOOK	STAINLESS STEEL	
4	44	ROLLER BEARING	COLD-ROLLED STEEL	
5	4	WHEEL	CAST IRON	
6	4	GUIDE AXLE	COLD-ROLLED STEEL	
7	12	ADJUSTING WASHER	STAINLESS STEEL	26 ID X 44 OD X 4 THK
8	4	WASHER	STAINLESS STEEL	
9	4	LOCKNUT	STAINLESS STEEL	M16 X 2
10	6	COTTER PIN	STAINLESS STEEL	Ø6 X 40 LG

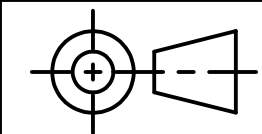

DIGITAL DESIGN  
GRAPHICS  
TECHNOLOGY

NAME:	L. BACUD
COURSE:	DDGT 120
DATE:	12/8/2014

DWG NAME:	14-83 TROLLEY
SCALE:	AS NOTED

PARTS LIST				
ITEM	QTY	PART NUMBER	MATERIAL	DESCRIPTION
1	2	SIDE PLATE RIVITED		
1.1	1	SIDE PLATE	MILD STEEL	
1.2	1	GUIDE	CAST IRON	
1.3	2	RIVET	STAINLESS STEEL	BUTTON HEAD, Ø10 X 60 LG
2	1	AXLE	COLD-ROLLED STEEL	
3	1	HOOK	STAINLESS STEEL	
4	44	ROLLER BEARING	COLD-ROLLED STEEL	
5	4	WHEEL	CAST IRON	
6	4	GUIDE AXLE	COLD-ROLLED STEEL	
7	12	ADJUSTING WASHER	STAINLESS STEEL	26 ID X 44 OD X 4 THK
8	4	WASHER	STAINLESS STEEL	
9	4	LOCKNUT	STAINLESS STEEL	M16 X 2
10	6	COTTER PIN	STAINLESS STEEL	Ø6 X 40 LG

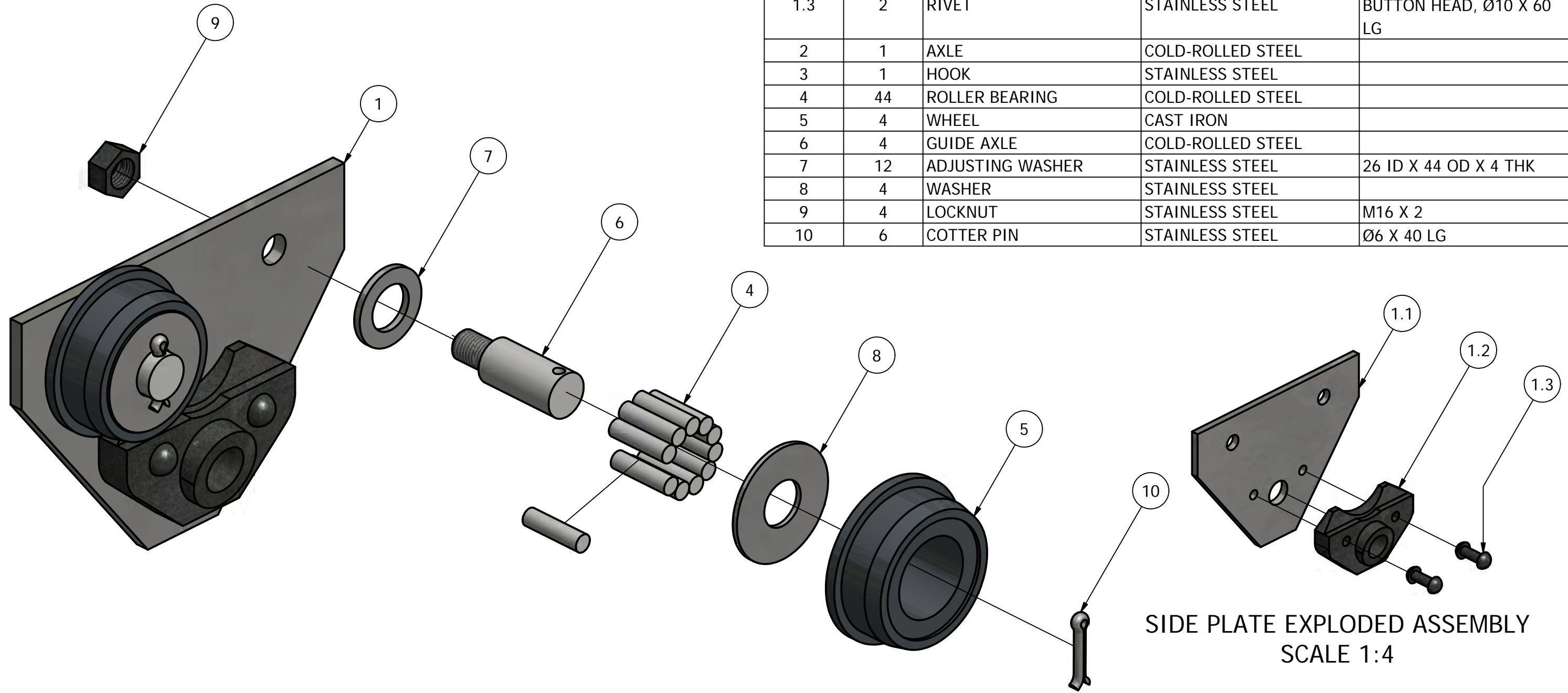

SIDE PLATE WITH WHEELS EXPLODED ASSEMBLY  
SCALE 1:2

SIDE PLATE EXPLODED ASSEMBLY  
SCALE 1:4

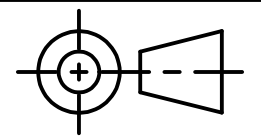

DIGITAL DESIGN  
GRAPHICS  
TECHNOLOGY

NAME:	L. BACUD
COURSE:	DDGT 120
DATE:	12/8/2014

DWG NAME:	14-83 TROLLEY
SCALE:	AS NOTED

PAGE #:  
2 OF 4

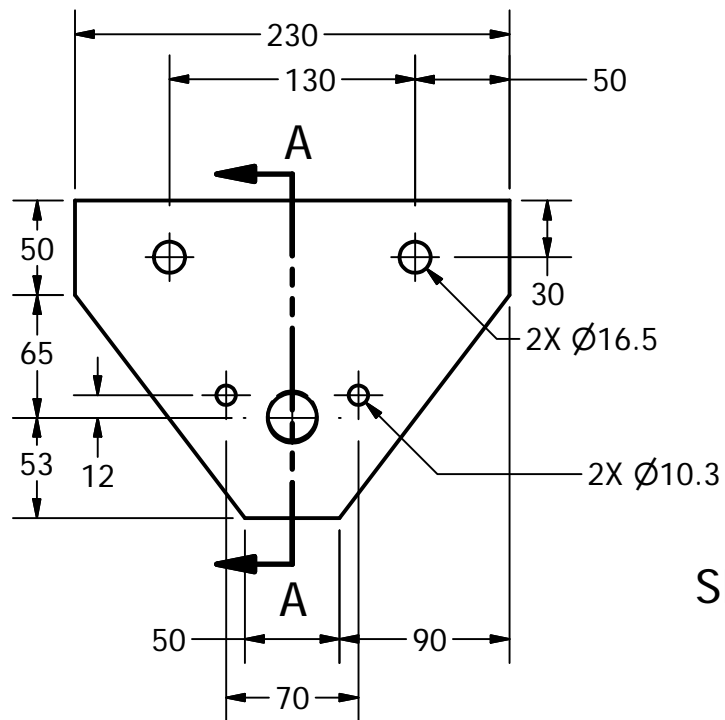

SIDE PLATE  
SCALE 1:4

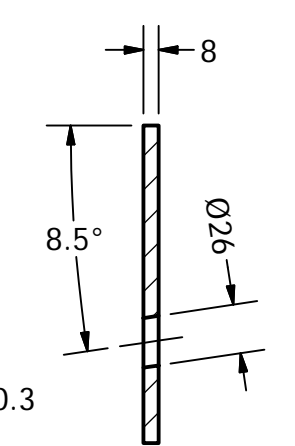

SECTION A-A  
SCALE 1:4

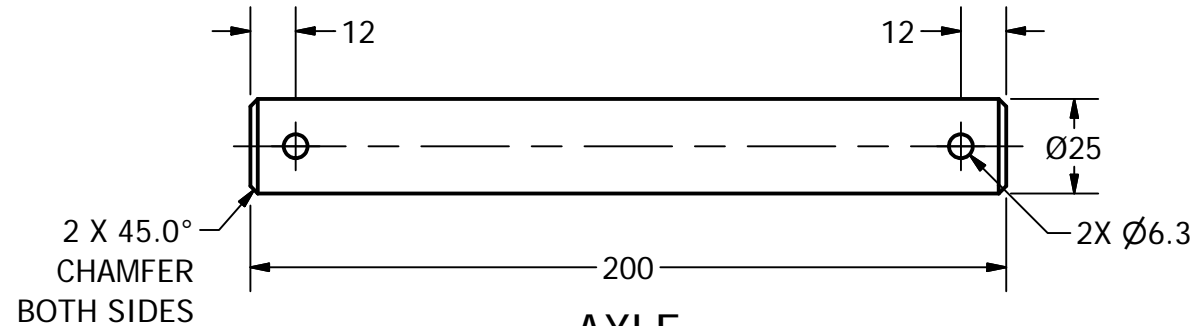
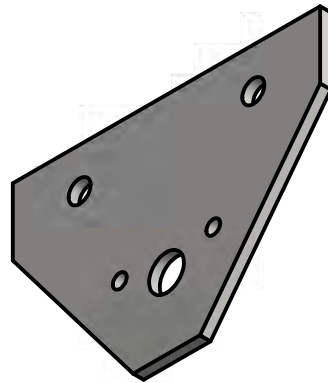

AXLE  
SCALE 1:2

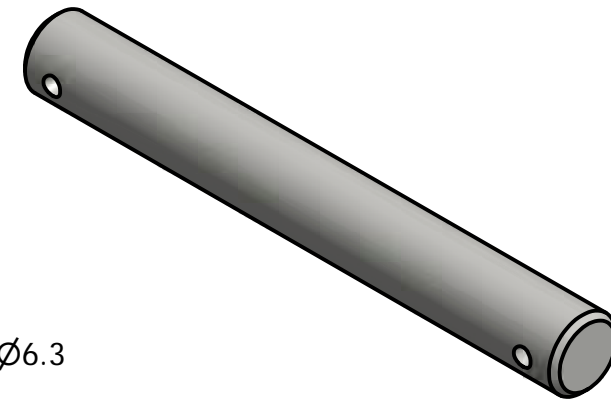

PARTS LIST		
ITEM	QTY	PART NUMBER
1.1	2	SIDE PLATE
1.2	2	GUIDE
2	1	AXLE

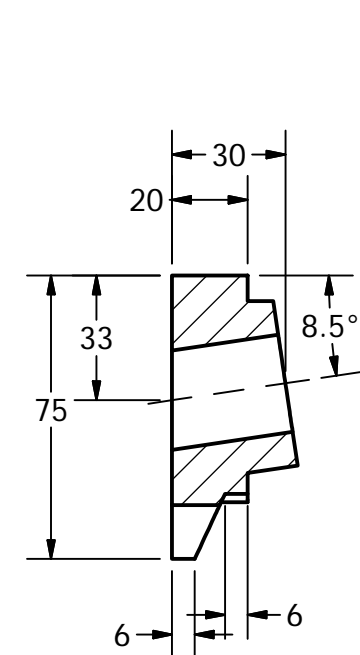

SECTION B-B  
SCALE 1:2

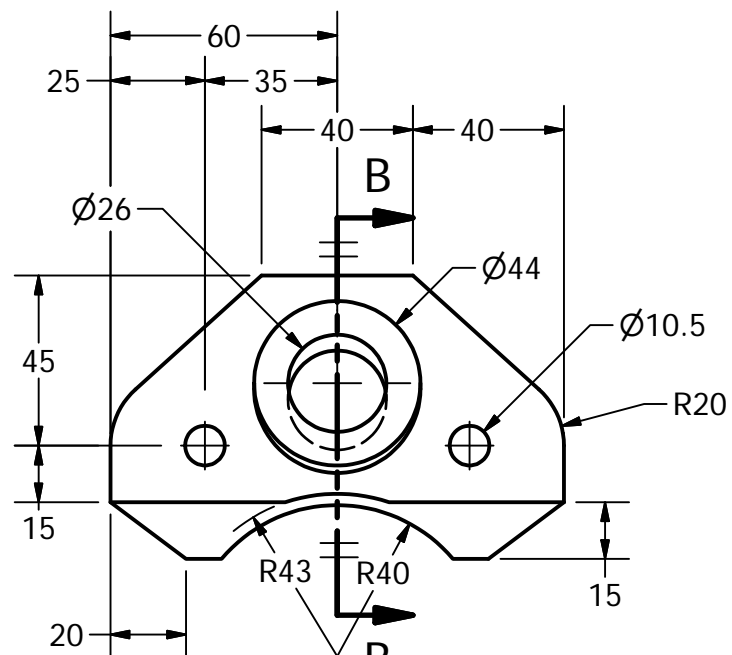

GUIDE  
SCALE 1:2

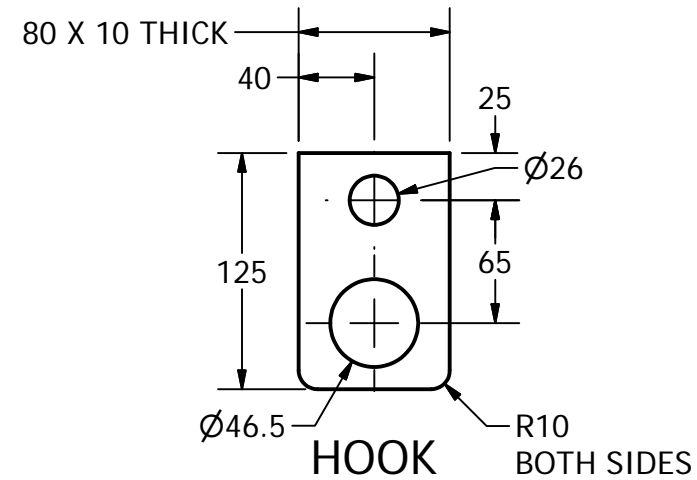
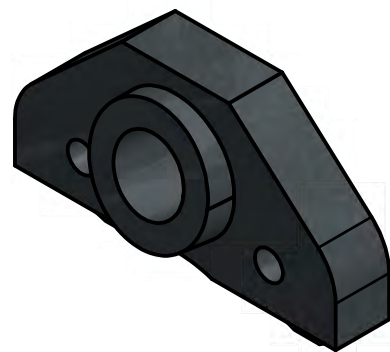

HOOK  
SCALE 1:4



**METRIC**

**LEGEND**

Ø DIAMETER  
R RADIUS  
° DEGREES

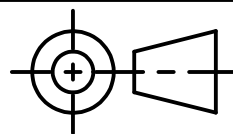

DIGITAL DESIGN  
GRAPHICS  
TECHNOLOGY

NAME: L. BACUD  
COURSE: DDGT 120  
DATE: 12/8/2014

DWG NAME: 14-83  
TROLLEY  
SCALE: AS NOTED

PAGE #: 3 OF 4

### PARTS LIST

ITEM	QTY	PART NUMBER
4	44	ROLLER BEARING
5	4	WHEEL
6	4	GUIDE AXLE

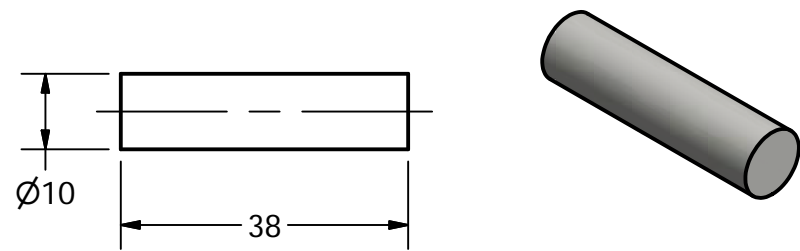

ROLLER BEARING  
SCALE 1:1

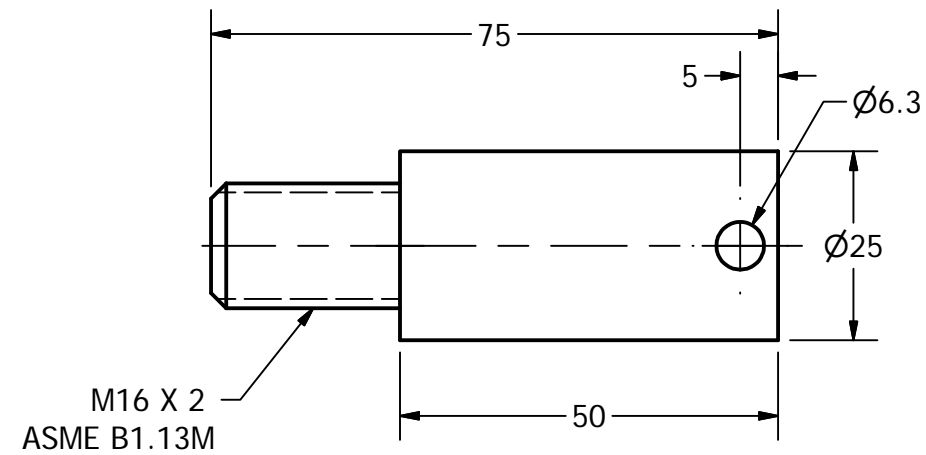

GUIDE AXLE  
SCALE 1:1

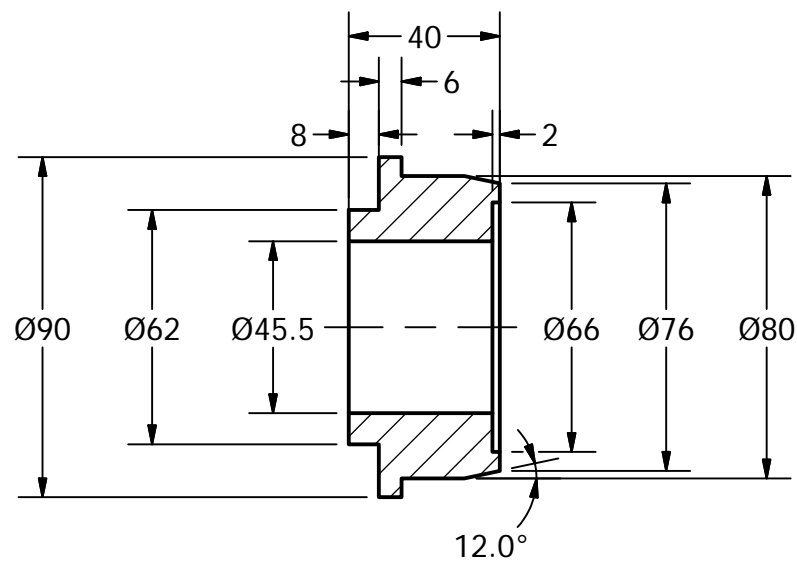

SECTION C-C  
SCALE 1:2

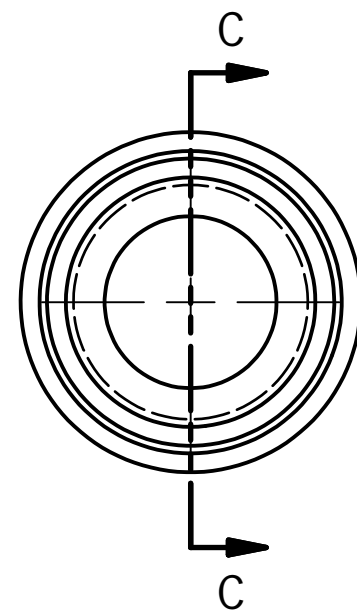

WHEEL  
SCALE 1:2



**METRIC**

### LEGEND

- Ø DIAMETER
- R RADIUS
- ° DEGREES

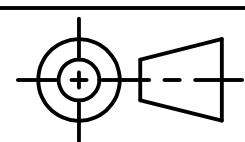

DIGITAL DESIGN  
GRAPHICS  
TECHNOLOGY

NAME:	L. BACUD
COURSE:	DDGT 120
DATE:	12/8/2014

DWG NAME:	14-83 TROLLEY
SCALE:	AS NOTED

PAGE #:  
4 OF 4