

PARTS LIST			
ITEM	QTY	PART NUMBER	MATERIAL
1	1	DRILL PRESS BRACKET	STEEL

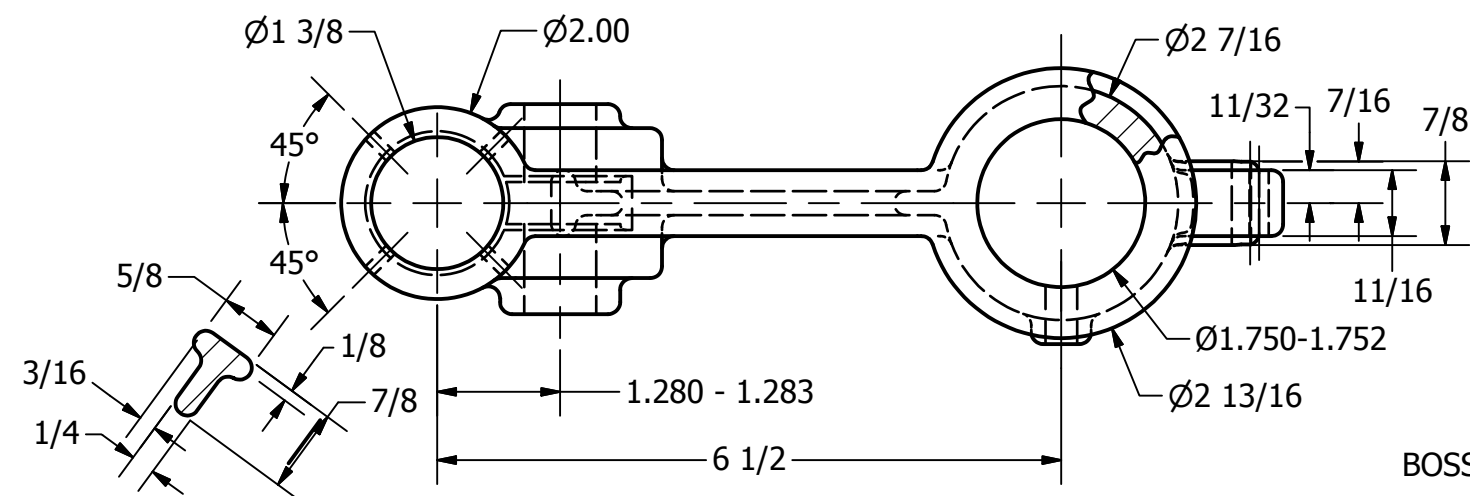

SECTION B-B
SCALE 1 / 2

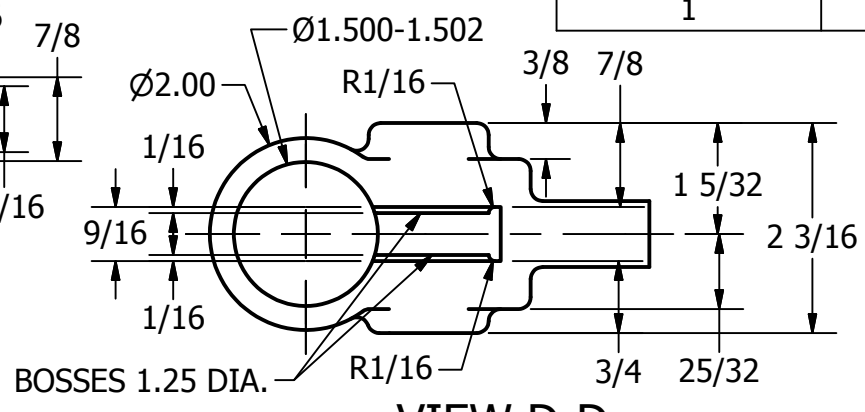

VIEW D-D
SCALE 1 / 2

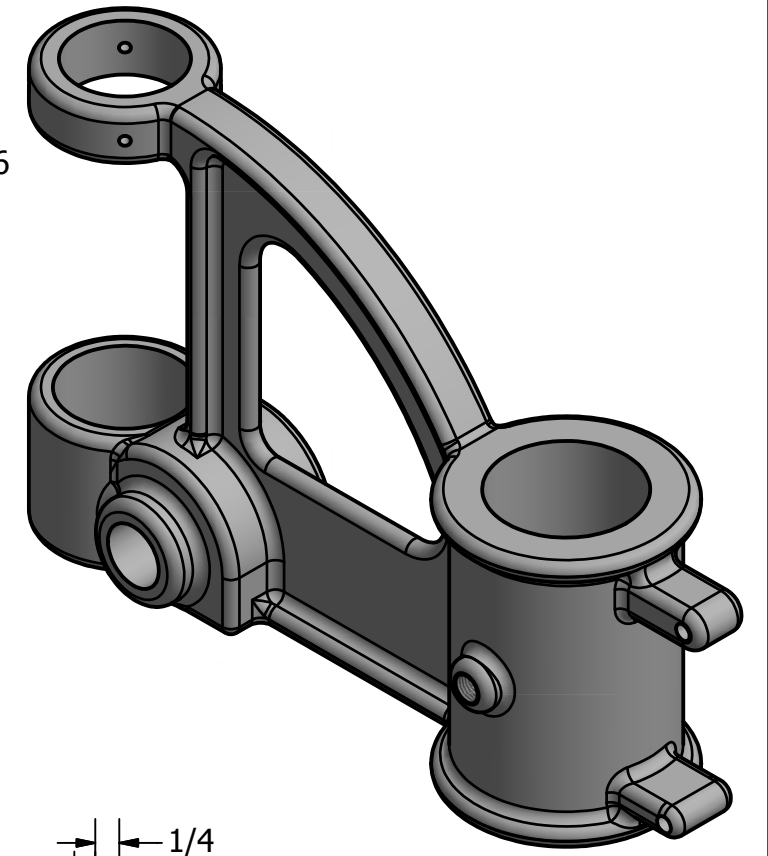

FILLETS & ROUNDS R.125
UNLESS OTHERWISE NOTED

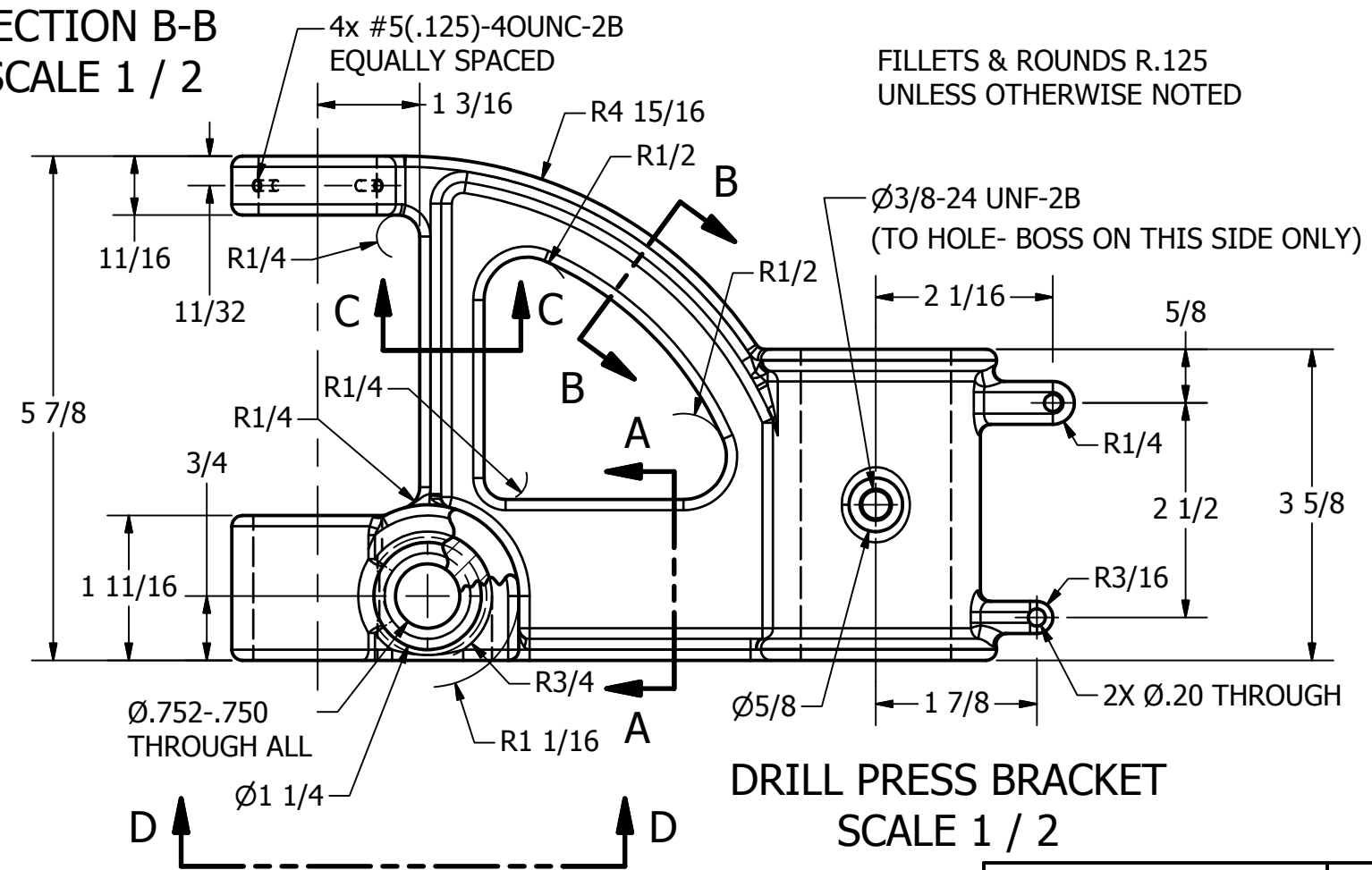

DRILL PRESS BRACKET
SCALE 1 / 2

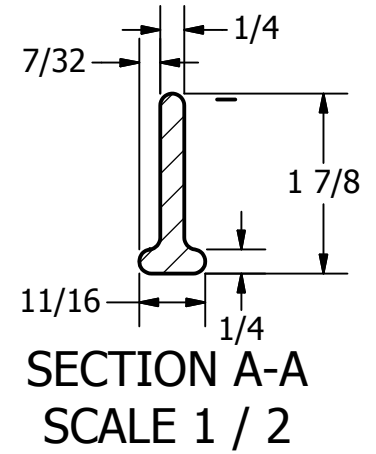
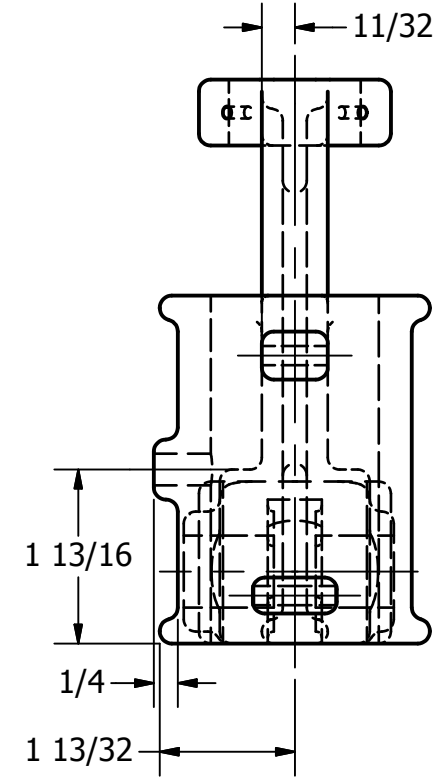

SECTION A-A
SCALE 1 / 2

LEGEND:
 Ø DIAMETER
 R RADIUS
 ° DEGREES

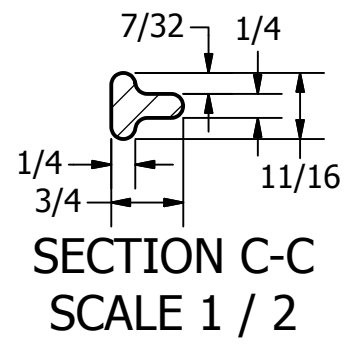

SECTION C-C
SCALE 1 / 2



DIGITAL DESIGN
GRAPHICS
TECHNOLOGY
WWW.DDGT.NET



LOUIE MILGROM
Drafter | Designer

louismilgrom@hotmail.com
707-227-5960

www.ddgt.net/studentpages/lmilgrom

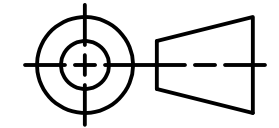

TOLERANCES UNLESS SPECIFIED:
 DECIMAL INCHES:
 X = ±.020
 XX = ±.010
 XXX = ±.005
 FRACTIONAL ±1/64"
 ANGLES ±1 DEGREE
 SURFACES $\sqrt{3}$

COURSE:	DDGT 121
INVENTOR IDW NAME:	DRILL PRESS BRACKET
FIG NO:	14-35
DRAFTER:	L. MILGROM
DATE:	4/8/2015
SCALE:	AS NOTED
PAGE NO:	1 OF 1