

MACHINE VISE
SCALE 1 : 1

PARTS LIST				
ITEM	QTY	PART NUMBER	MATERIAL	DESCRIPTION
1	1	BASE	CAST IRON	
2	1	SLIDING JAW	CAST IRON	
3	2	JAW PLATE	SAE 3140	
4	1	WISE SCREW	SAE 3140	
5	1	COLLAR	SAE 1020	
6	2	HANDLE BALL	SAE 1020	
7	1	HANDLE ROD	COLD ROLLED STEEL	
8	2	SET SCREW	SAE 1016	
9	2	SLIDE KEY	SAE 1020	
10	1	SPECIAL KEY	SAE 1020	
11	2	TAPER PIN	STANDARD	#000 TAPER
12	4	STEEL SLOTTED FLAT HEAD SCREW	STANDARD	1/4"20 UNC-2B, 5/8 DEEP

GENERAL NOTES:

ALL FILLETS AND ROUNDS R 1/8" UNLESS OTHERWISE STATED.

LEGEND:

- ∅ DIAMETER
- R RADIUS
- ° DEGREES
- COUNTERBORE/
SPOTFACE
- ∨ COUNTERSINK
- ▽ DEPTH



DIGITAL DESIGN
GRAPHICS
TECHNOLOGY

WWW.DDGT.NET

LUIS RAMIREZ SOTO
GRAPHIC DESIGNER

707-302-4704

RAMIREZLUIS2020@OUTLOOK.COM

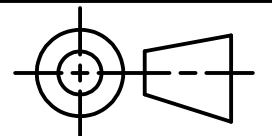

TOLERANCES UNLESS SPECIFIED:
DECIMAL INCHES
X = ±.020
XX = ±.010
XXX = ±.005
FRACTIONAL ±1/64"
ANGLES ±1 DEGREE
SURFACES ³²√

CLASS: DDGT240

ASSIGNMENT #: 38

INVENTOR DRAWING NAME:
MACHINE VISE

FIG #: 14-71

MANAGER: G. STROMMEN

DRAFTER: L. RAMIREZSOTO

DATE: 10/10/2024

SCALE: AS NOTED

PAGE #: 1 OF 9

PARTS LIST			
ITEM	QTY	PART NUMBER	MATERIAL
1	1	BASE	CAST IRON
3	2	JAW PLATE	SAE 3140
12	4	STEEL SLOTTED FLAT HEAD SCREW	STANDARD



DIGITAL DESIGN
GRAPHICS
TECHNOLOGY

WWW.DDGT.NET

LUIS RAMIREZ SOTO
GRAPHIC DESIGNER
707-302-4704
RAMIREZLUIS2020@OUTLOOK.COM

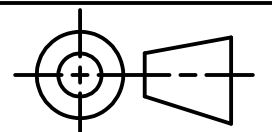

TOLERANCES UNLESS SPECIFIED:
DECIMAL INCHES
X = ±.020
XX = ±.010
XXX = ±.005
FRACTIONAL ±1/64"
ANGLES ±1 DEGREE
SURFACES ³²✓

CLASS: DDGT240

ASSIGNMENT #: 38

INVENTOR DRAWING NAME:
MACHINE VISE

FIG #: 14-71

MANAGER: G. STROMMEN

DRAFTER: L. RAMIREZSOTO

DATE: 10/10/2024

SCALE: AS NOTED

PAGE #: 2 OF 9

LEGEND:

- ∅ DIAMETER
- R RADIUS
- ° DEGREES
- COUNTERBORE/
SPOTFACE
- ∨ COUNTERSINK
- ∇ DEPTH

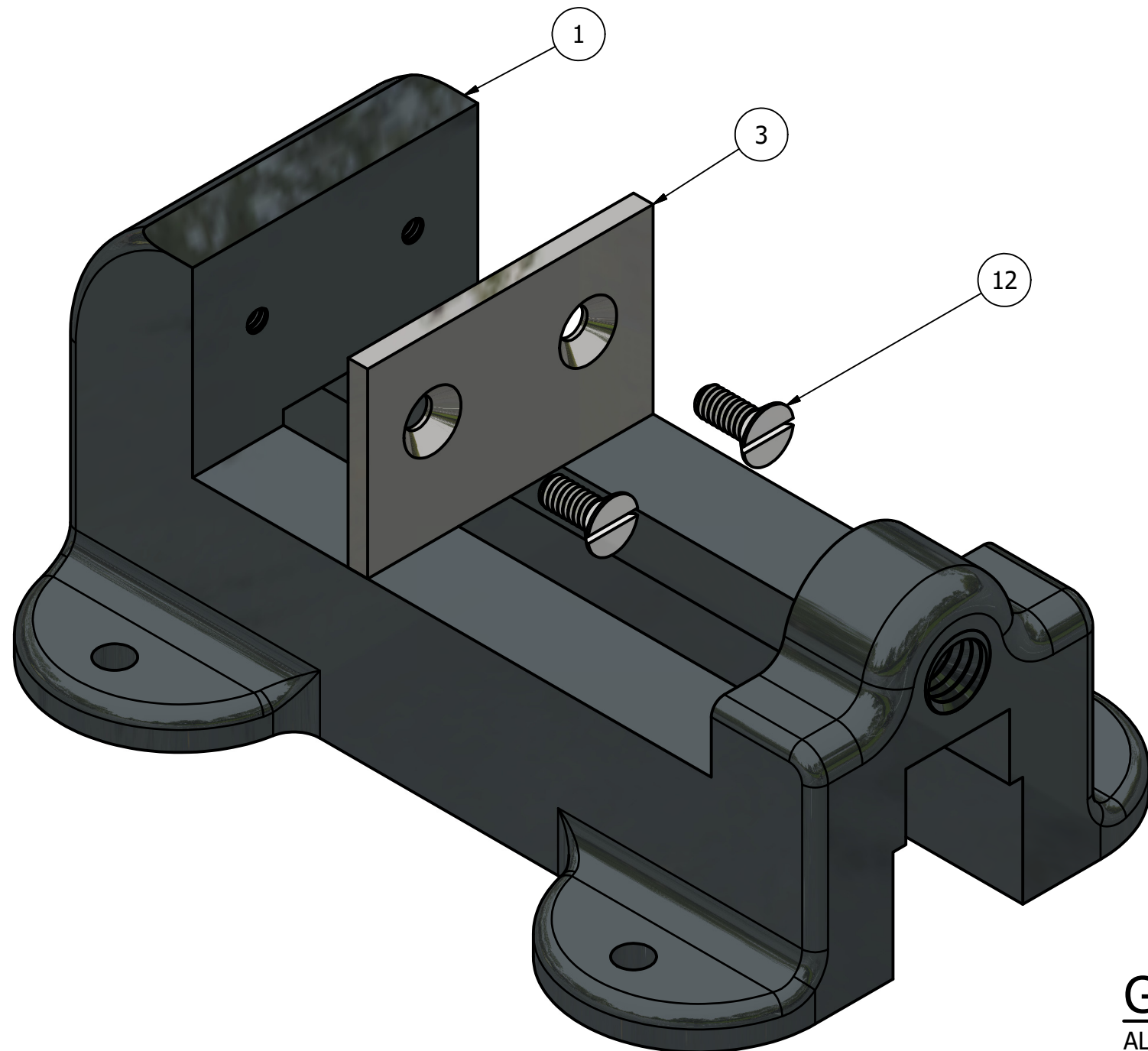

STEP 1
SCALE 1 : 1

GENERAL NOTES:

ALL FILLETS AND ROUNDS R 1/8" UNLESS OTHERWISE STATED.

PARTS LIST			
ITEM	QTY	PART NUMBER	MATERIAL
2	1	SLIDING JAW	CAST IRON
3	2	JAW PLATE	SAE 3140
12	4	STEEL SLOTTED FLAT HEAD SCREW	STANDARD



DIGITAL DESIGN
GRAPHICS
TECHNOLOGY

WWW.DDGT.NET

LUIS RAMIREZ SOTO
GRAPHIC DESIGNER
707-302-4704
RAMIREZLUIS2020@OUTLOOK.COM

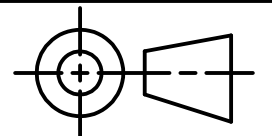

TOLERANCES UNLESS SPECIFIED:
DECIMAL INCHES
X = ±.020
XX = ±.010
XXX = ±.005
FRACTIONAL ±1/64"
ANGLES ±1 DEGREE
SURFACES ³²✓

CLASS: DDGT240

ASSIGNMENT #: 38

INVENTOR DRAWING NAME:
MACHINE VISE

FIG #: 14-71

MANAGER: G. STROMMEN

DRAFTER: L. RAMIREZSOTO

DATE: 10/10/2024

SCALE: AS NOTED

PAGE #: 3 OF 9

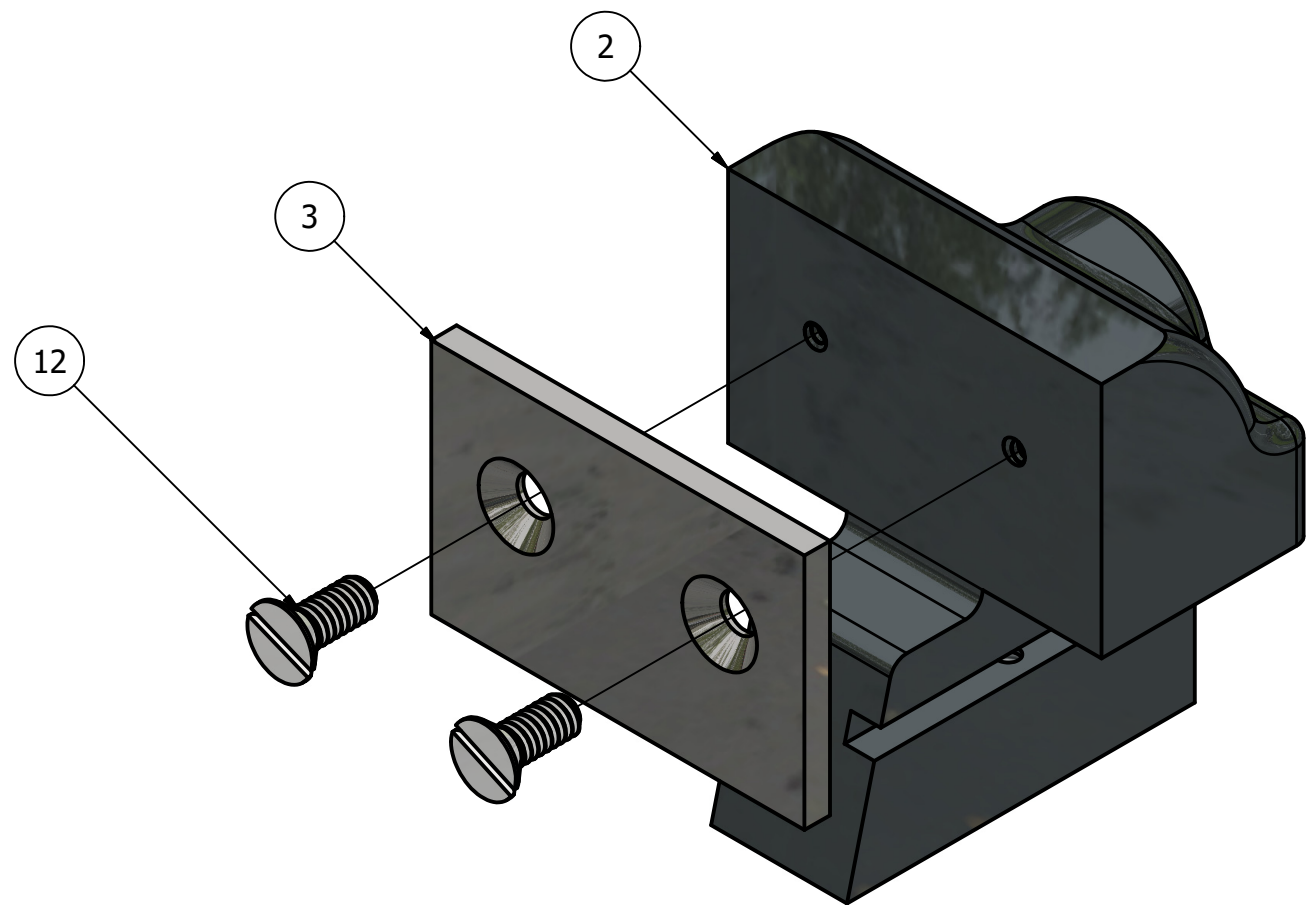

STEP 2
SCALE 1 : 1

LEGEND:

- ∅ DIAMETER
- R RADIUS
- ° DEGREES
- COUNTERBORE/
SPOTFACE
- ∨ COUNTERSINK
- ∇ DEPTH

GENERAL NOTES:

ALL FILLETS AND ROUNDS R 1/8" UNLESS OTHERWISE STATED.

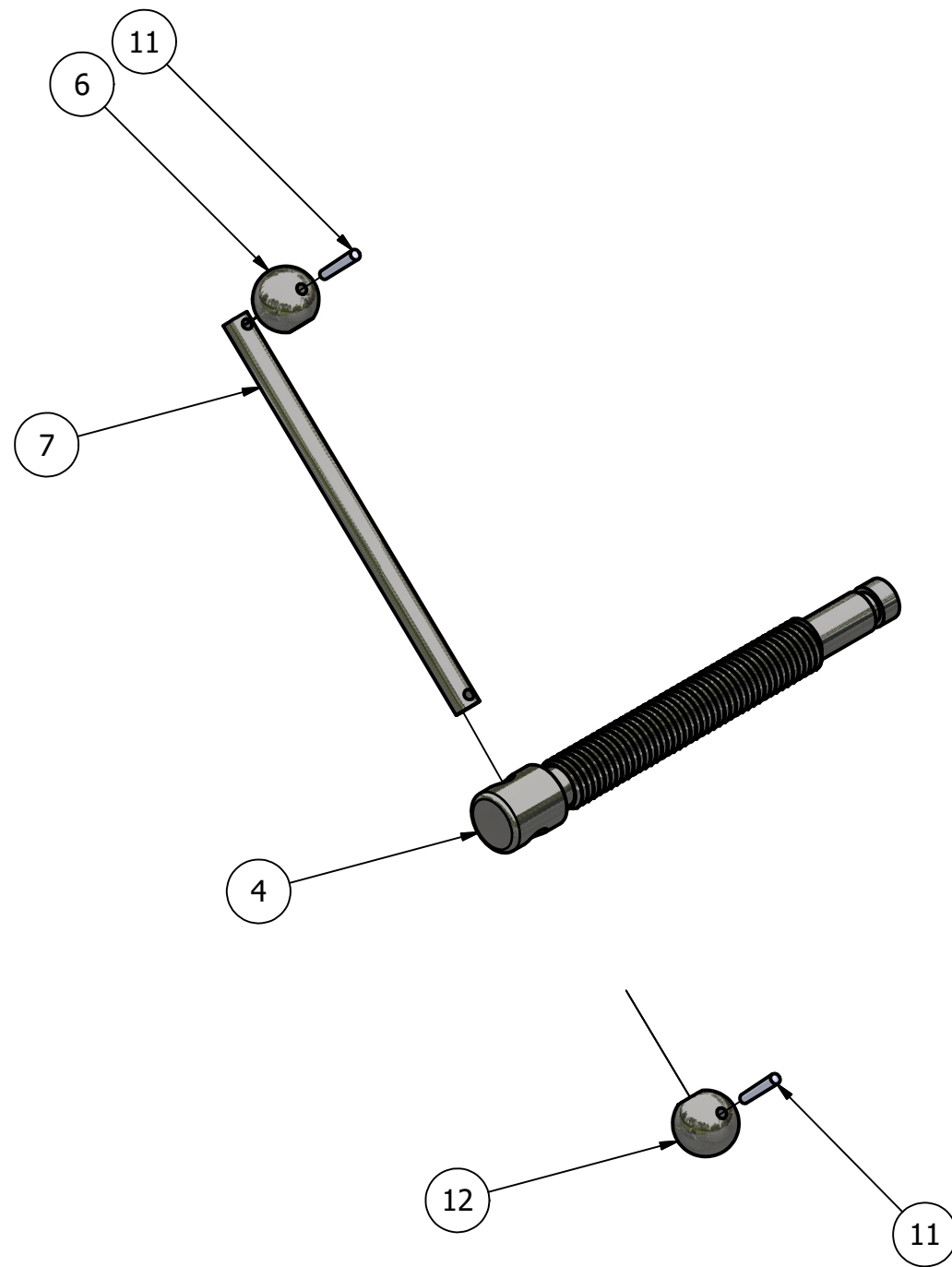

STEP 3
SCALE 1 / 2

PARTS LIST			
ITEM	QTY	PART NUMBER	MATERIAL
4	1	WISE SCREW	SAE 3140
6	2	HANDLE BALL	SAE 1020
7	1	HANDLE ROD	COLD ROLLED STEEL
10	1	SPECIAL KEY	SAE 1020
11	2	TAPER PIN	STANDARD

LEGEND:

- ∅ DIAMETER
- R RADIUS
- ° DEGREES
- COUNTERBORE/
SPOTFACE
- ∨ COUNTERSINK
- ∇ DEPTH

GENERAL NOTES:

ALL FILLETS AND ROUNDS R 1/8" UNLESS OTHERWISE STATED.



DIGITAL DESIGN
GRAPHICS
TECHNOLOGY

WWW.DDGT.NET

LUIS RAMIREZ SOTO
GRAPHIC DESIGNER

707-302-4704

RAMIREZLUIS202@OUTLOOK.COM

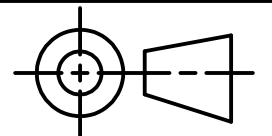

TOLERANCES UNLESS SPECIFIED:
DECIMAL INCHES
X = ±.020
XX = ±.010
XXX = ±.005
FRACTIONAL ±1/64"
ANGLES ±1 DEGREE
SURFACES ³²∨

CLASS: DDGT240

ASSIGNMENT #: 38

INVENTOR DRAWING NAME:
MACHINE VISE

FIG #: 14-71

MANAGER: G. STROMMEN

DRAFTER: L. RAMIREZSOTO

DATE: 10/10/2024

SCALE: AS NOTED

PAGE #: 4 OF 9

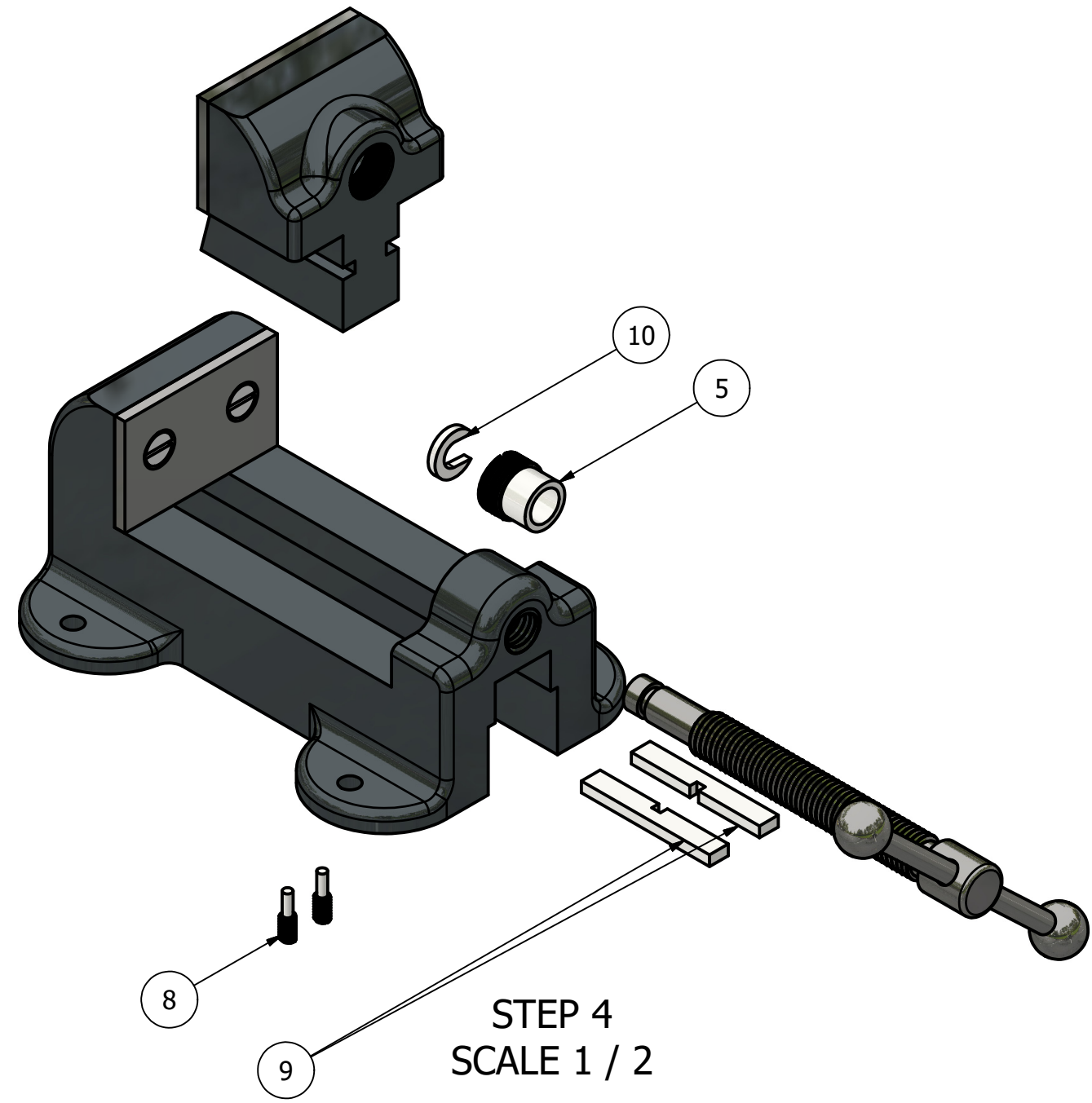

PARTS LIST			
ITEM	QTY	PART NUMBER	MATERIAL
5	1	COLLAR	SAE 1020
8	2	SET SCREW	SAE 1016
9	2	SLIDE KEY	SAE 1020
10	1	SPECIAL KEY	SAE 1020

LEGEND:

- ∅ DIAMETER
- R RADIUS
- ° DEGREES
- COUNTERBORE/
SPOTFACE
- ∨ COUNTERSINK
- ▽ DEPTH

GENERAL NOTES:

ALL FILLETS AND ROUNDS R 1/8" UNLESS OTHERWISE STATED.



DIGITAL DESIGN
GRAPHICS
TECHNOLOGY

WWW.DDGT.NET

LUIS RAMIREZ SOTO
GRAPHIC DESIGNER
707-302-4704
RAMIREZLUIS2020@OUTLOOK.COM

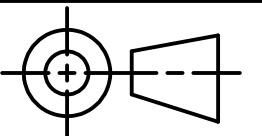

TOLERANCES UNLESS SPECIFIED:
DECIMAL INCHES
X = ±.020
XX = ±.010
XXX = ±.005
FRACTIONAL ±1/64"
ANGLES ±1 DEGREE
SURFACES ³²✓

CLASS: DDGT240

ASSIGNMENT #: 38

INVENTOR DRAWING NAME:
MACHINE VISE

FIG #: 14-71

MANAGER: G. STROMMEN

DRAFTER: L. RAMIREZSOTO

DATE: 10/10/2024

SCALE: AS NOTED

PAGE #: 5 OF 9

LEGEND:

- ∅ DIAMETER
- R RADIUS
- ° DEGREES
- ┌ COUNTERBORE/
SPOTFACE
- ∨ COUNTERSINK
- ∇ DEPTH

PARTS LIST			
ITEM	QTY	PART NUMBER	MATERIAL
1	1	BASE	CAST IRON



DIGITAL DESIGN
GRAPHICS
TECHNOLOGY

WWW.DDGT.NET

LUIS RAMIREZ SOTO
GRAPHIC DESIGNER
707-302-4704
RAMIREZLUIS2020@OUTLOOK.COM

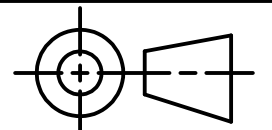

TOLERANCES UNLESS SPECIFIED:
DECIMAL INCHES
X = ±.020
XX = ±.010
XXX = ±.005
FRACTIONAL ±1/64"
ANGLES ±1 DEGREE
SURFACES ³²✓

CLASS: DDGT240

ASSIGNMENT #: 38

INVENTOR DRAWING NAME:
MACHINE VISE

FIG #: 14-71

MANAGER: G. STROMMEN

DRAFTER: L. RAMIREZSOTO

DATE: 10/10/2024

SCALE: AS NOTED

PAGE #: 6 OF 9

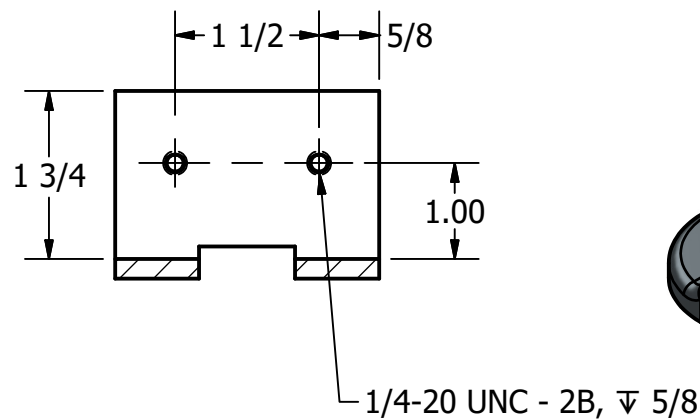
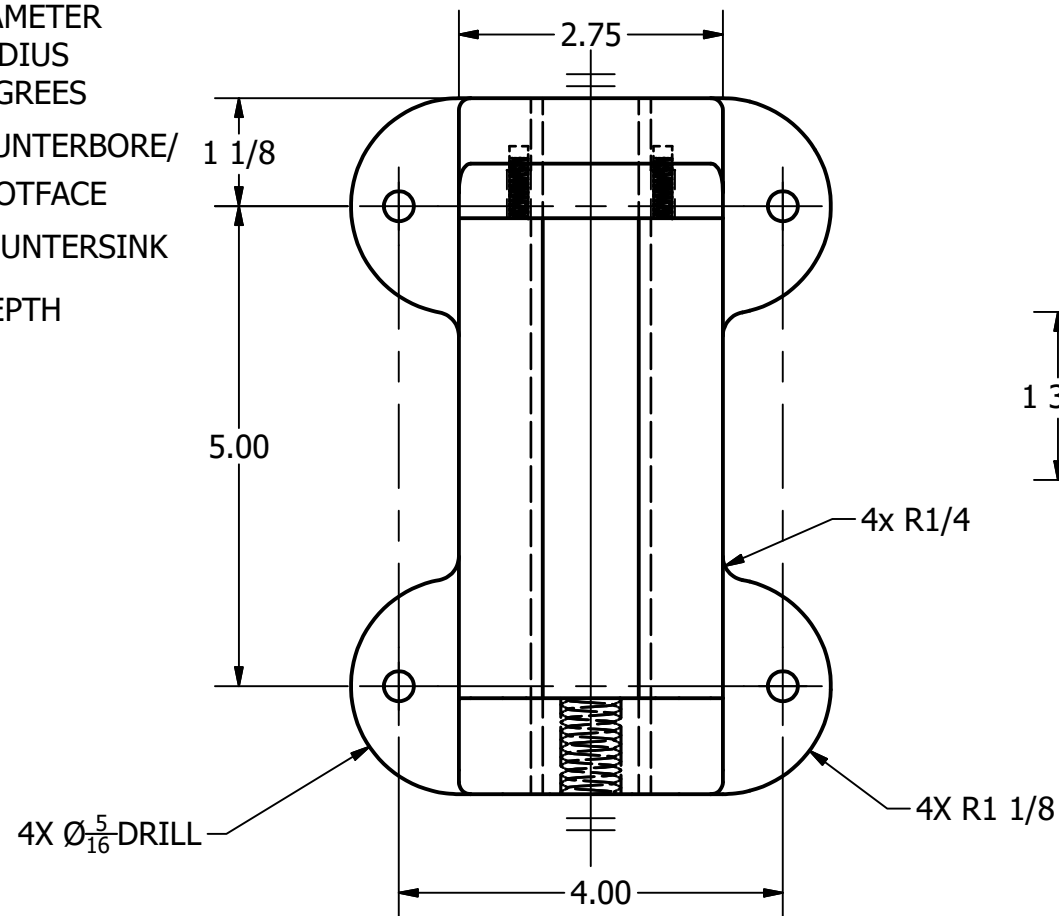

SECTION A-A
SCALE 1 / 2

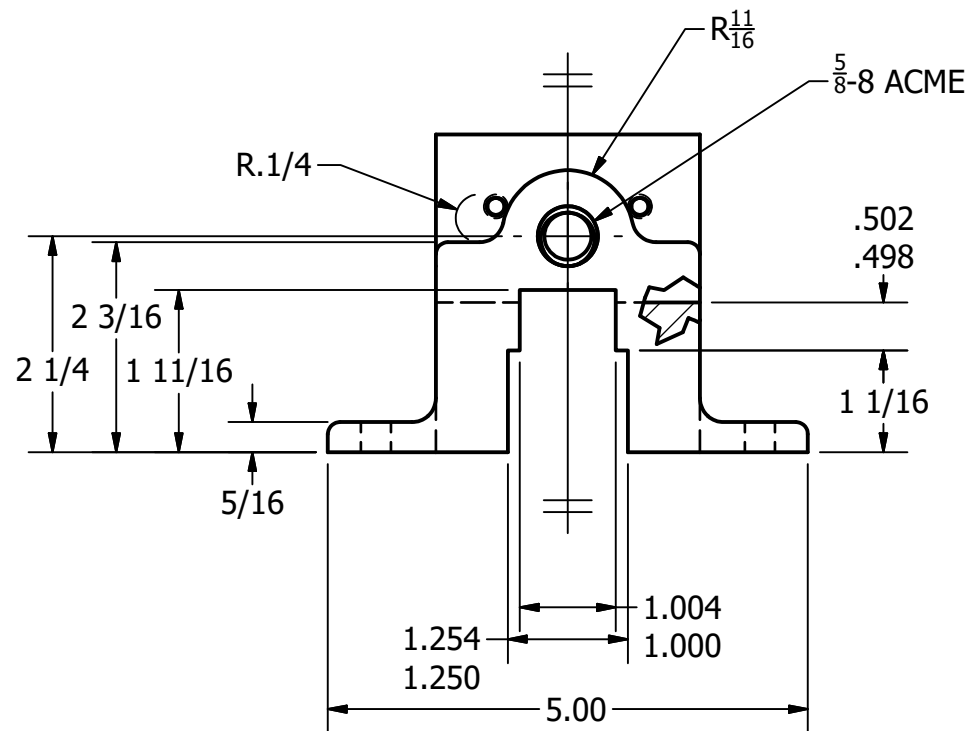
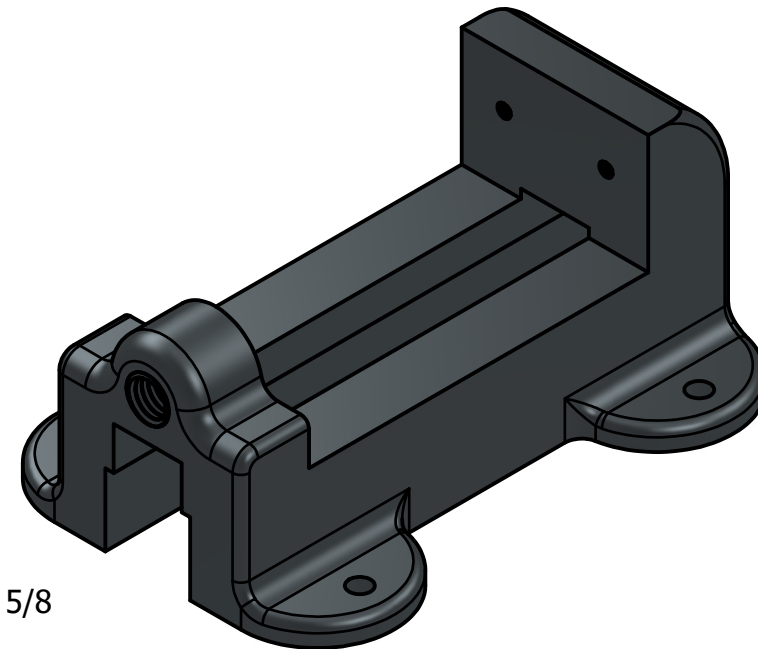

BASE
SCALE 1 / 2

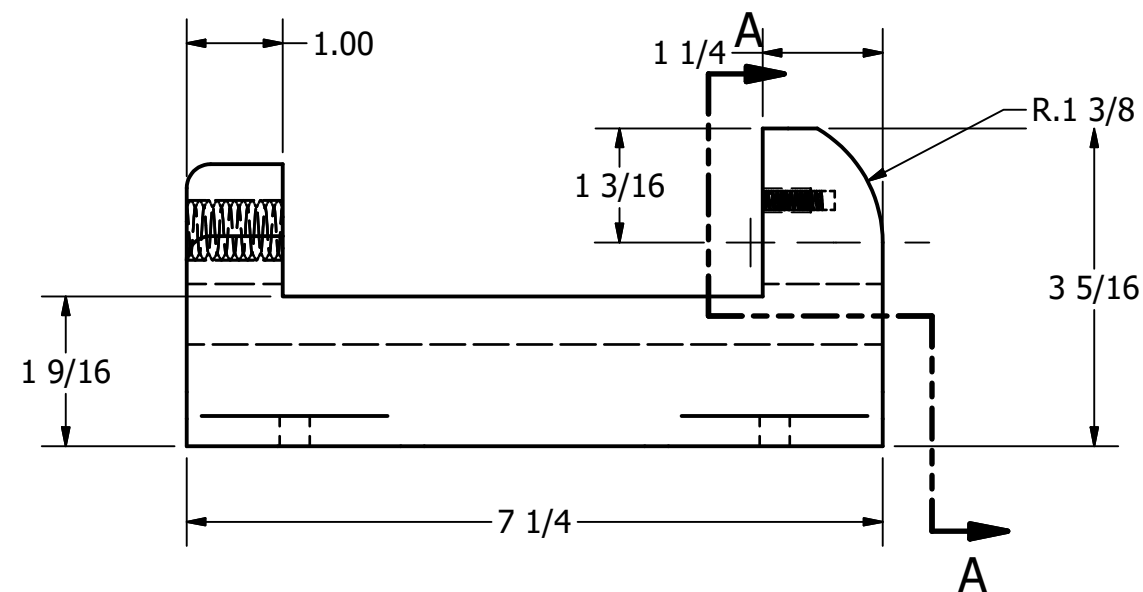

GENERAL NOTES:
ALL FILLETS AND ROUNDS R 1/8" UNLESS OTHERWISE STATED.

PARTS LIST			
ITEM	QTY	PART NUMBER	MATERIAL
2	1	SLIDING JAW	CAST IRON



DIGITAL DESIGN
GRAPHICS
TECHNOLOGY

WWW.DDGT.NET

LUIS RAMIREZ SOTO
GRAPHIC DESIGNER
707-302-4704
RAMIREZLUIS202@OUTLOOK.COM

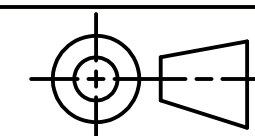

TOLERANCES UNLESS SPECIFIED:
DECIMAL INCHES
X = ±.020
XX = ±.010
XXX = ±.005
FRACTIONAL ±1/64"
ANGLES ±1 DEGREE
SURFACES ³²✓

CLASS: DDGT240

ASSIGNMENT #: 38

INVENTOR DRAWING NAME:
MACHINE VISE

FIG #: 14-71

MANAGER: G. STROMMEN

DRAFTER: L. RAMIREZSOTO

DATE: 10/10/2024

SCALE: AS NOTED

PAGE #: 7 OF 9

LEGEND:

- ∅ DIAMETER
- R RADIUS
- ° DEGREES
- ┌ COUNTERBORE/
SPOTFACE
- ∨ COUNTERSINK
- ∇ DEPTH

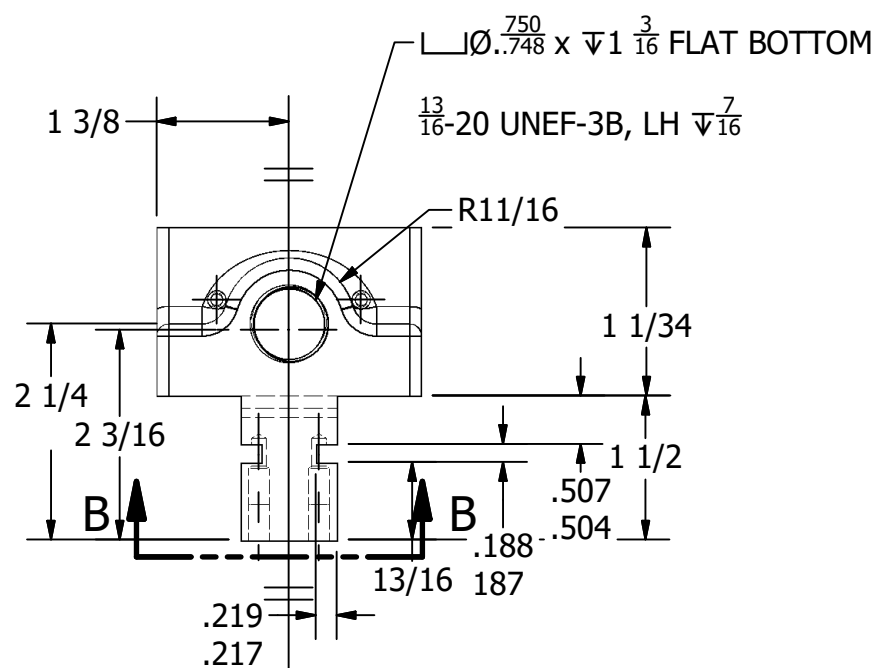

SLIDING JAW
SCALE 1 / 2

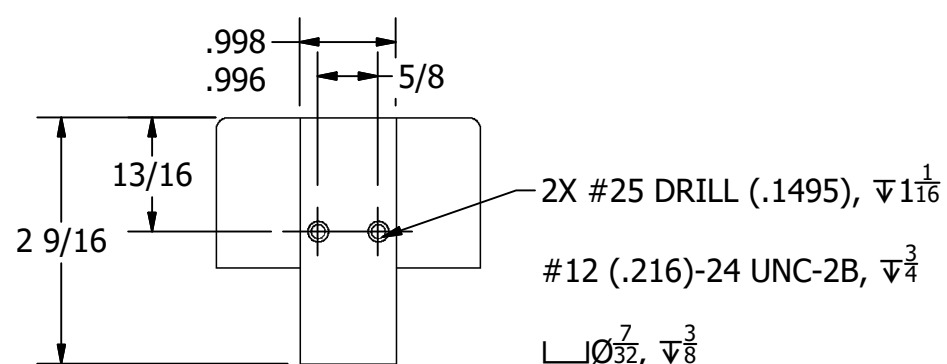

VIEW B-B
SCALE 1 / 2

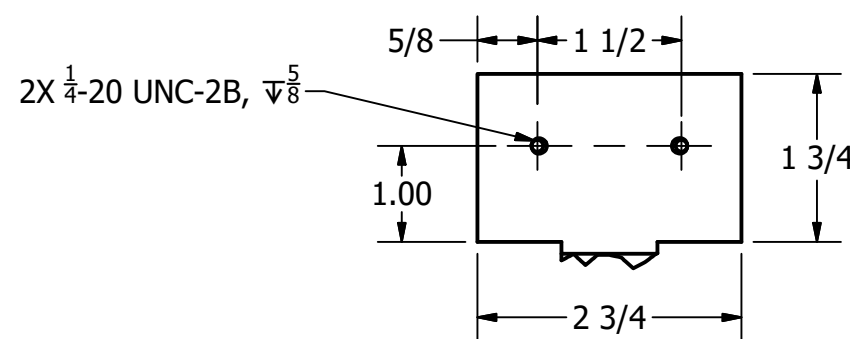
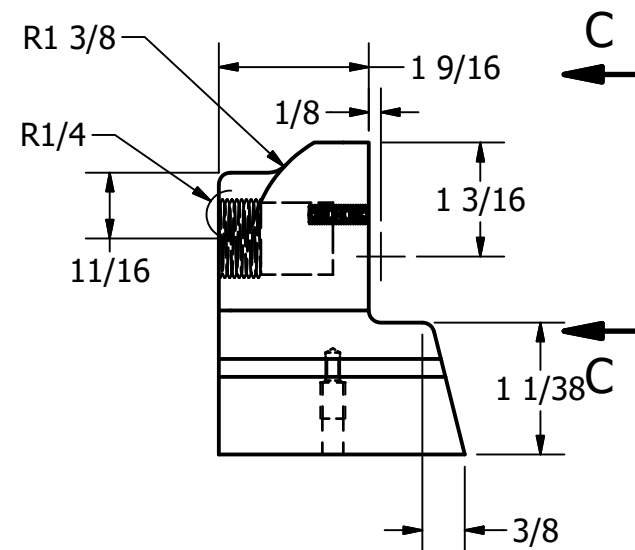

VIEW C-C
SCALE 1 / 2

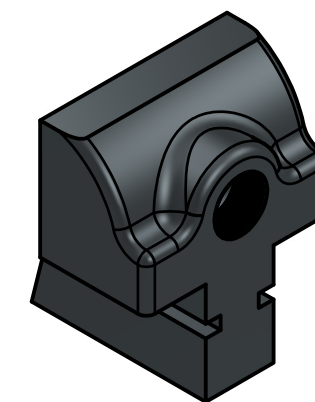

GENERAL NOTES:

ALL FILLETS AND ROUNDS R 1/8" UNLESS OTHERWISE STATED.

PARTS LIST			
ITEM	QTY	PART NUMBER	MATERIAL
4	1	WISE SCREW	SAE 3140
8	2	SET SCREW	SAE 1016
9	2	SLIDE KEY	SAE 1020

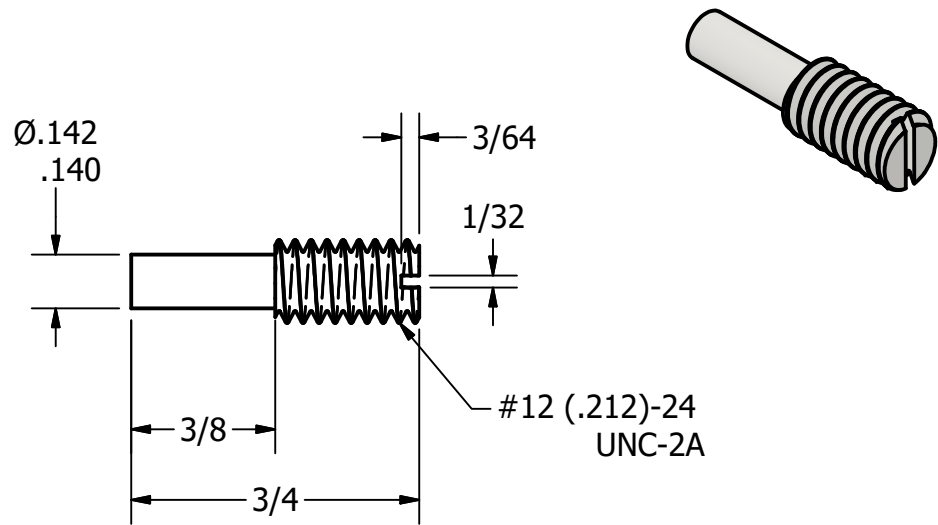

SET SCREW
SCALE 2 : 1

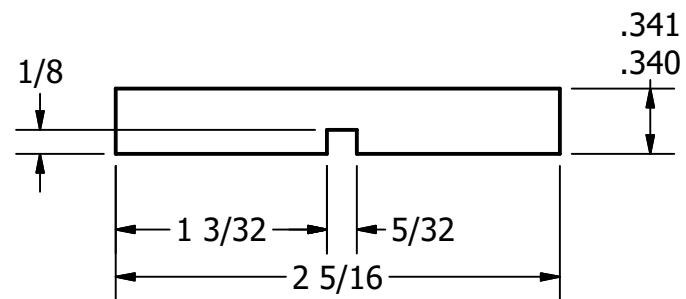

SLIDE KEY
SCALE 1 : 1

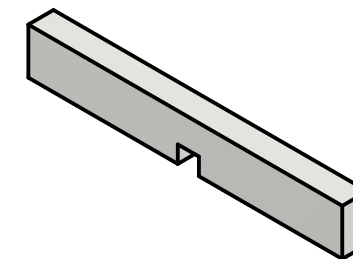

LEGEND:

- Ø DIAMETER
- R RADIUS
- ° DEGREES
- COUNTERBORE/
SPOTFACE
- ∨ COUNTERSINK
- ∇ DEPTH

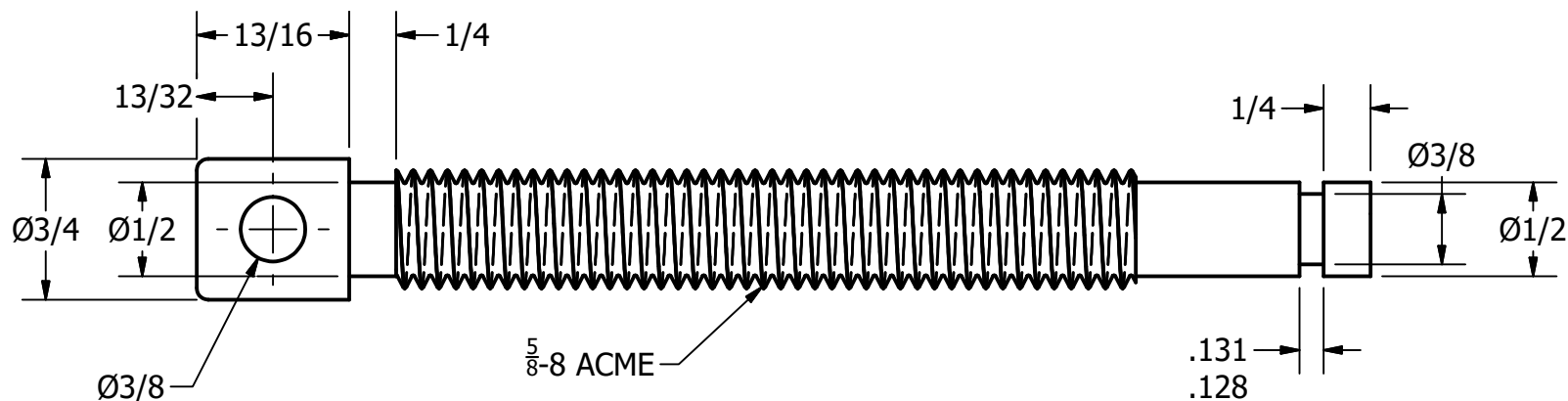

VIEW SCREW
SCALE 1 : 1

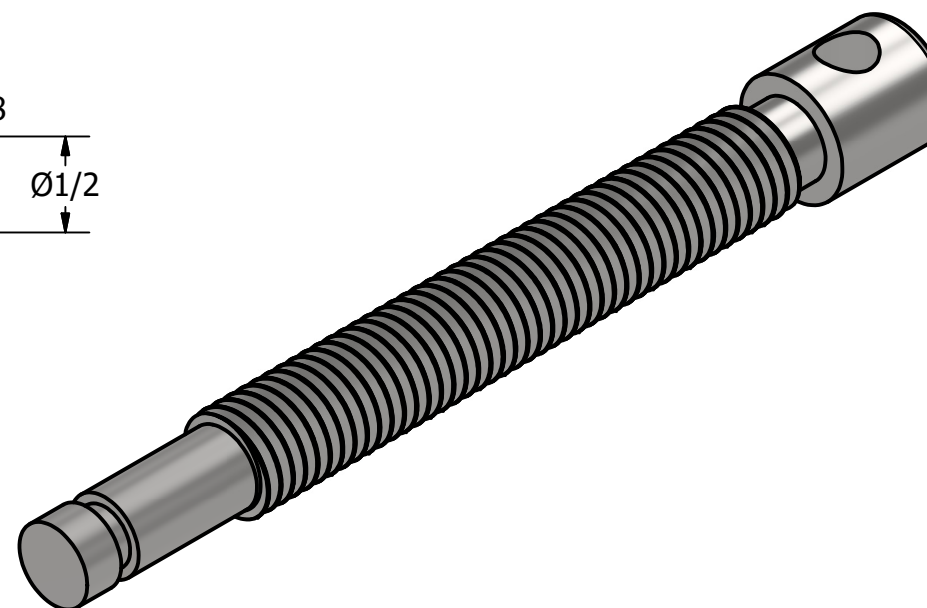

GENERAL NOTES:

ALL FILLETS AND ROUNDS R 1/8" UNLESS OTHERWISE STATED.

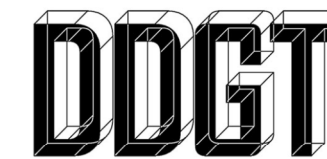

DIGITAL DESIGN
GRAPHICS
TECHNOLOGY

WWW.DDGT.NET

LUIS RAMIREZ SOTO
GRAPHIC DESIGNER

707-302-4704

RAMIREZLUIS202@OUTLOOK.COM

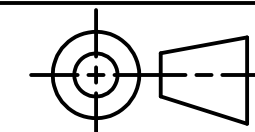

TOLERANCES UNLESS SPECIFIED:
DECIMAL INCHES
X = ±.020
XX = ±.010
XXX = ±.005
FRACTIONAL ±1/64"
ANGLES ±1 DEGREE
SURFACES ³²✓

CLASS: DDGT240

ASSIGNMENT #: 38

INVENTOR DRAWING NAME:
MACHINE VISE

FIG #: 14-71

MANAGER: G. STROMMEN

DRAFTER: L. RAMIREZSOTO

DATE: 10/10/2024

SCALE: AS NOTED

PAGE #: 8 OF 9

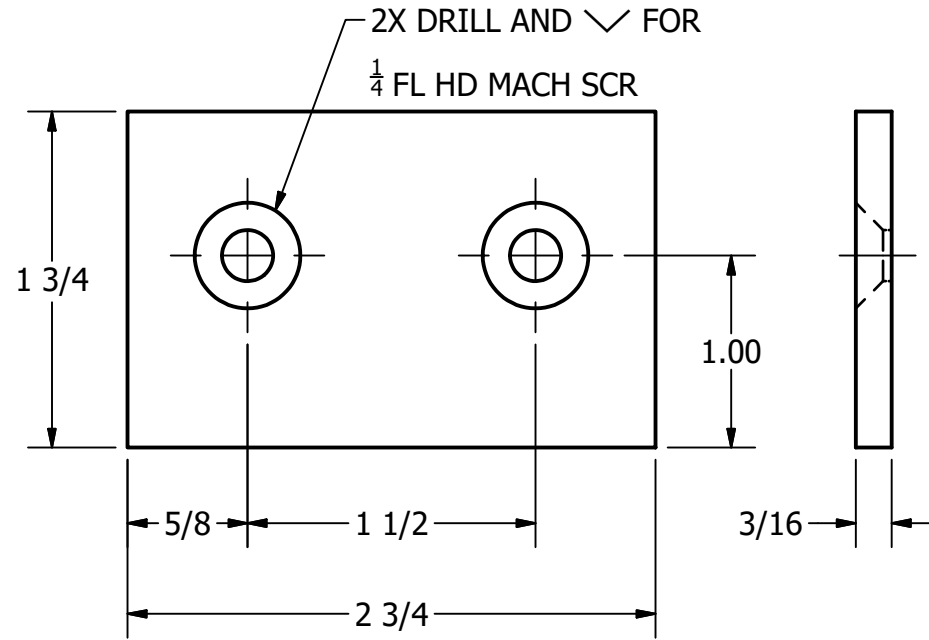

JAW PLATE
SCALE 1 : 1

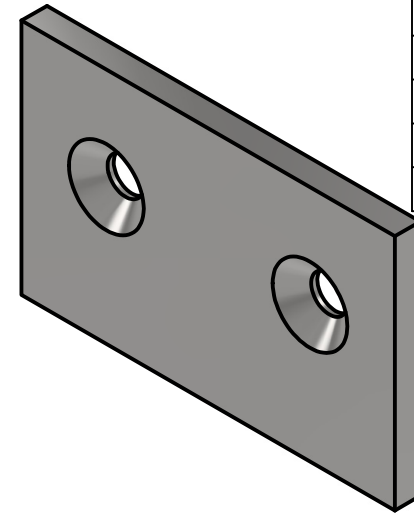

PARTS LIST			
ITEM	QTY	PART NUMBER	MATERIAL
3	2	JAW PLATE	SAE 3140
5	1	COLLAR	SAE 1020
6	2	HANDLE BALL	SAE 1020
7	1	HANDLE ROD	COLD ROLLED STEEL
10	1	SPECIAL KEY	SAE 1020

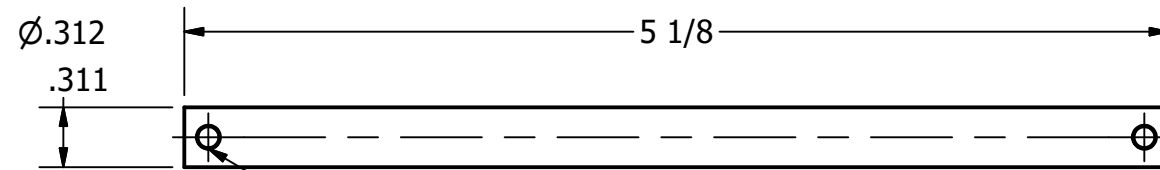
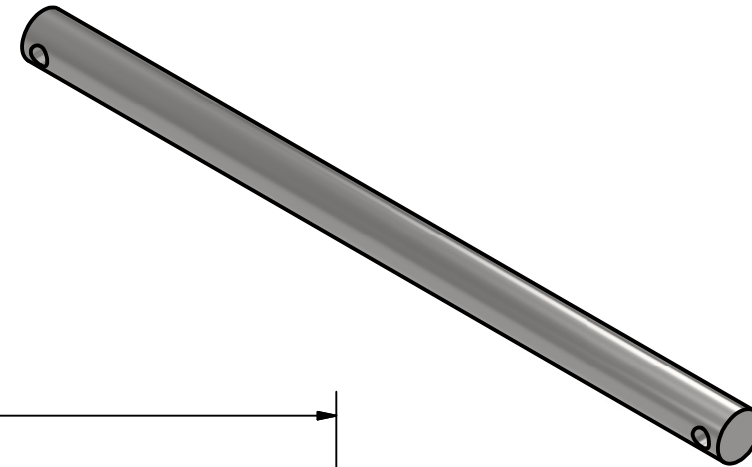

HANDLE ROD
SCALE 1 : 1

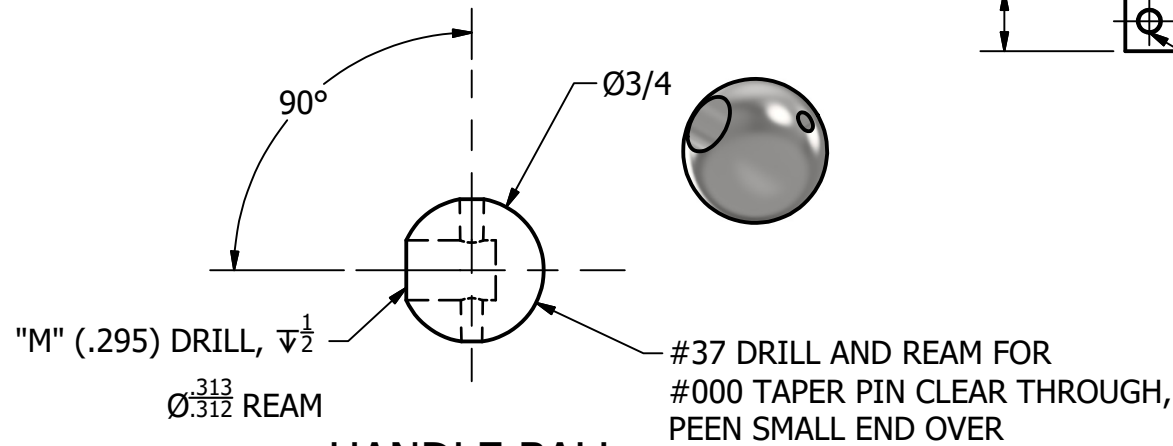

HANDLE BALL
SCALE 1 : 1

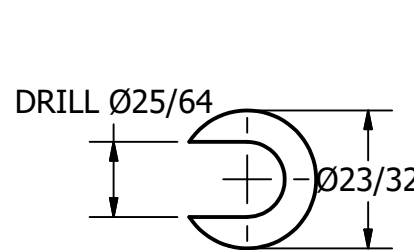

SPECIAL KEY
SCALE 1 : 1

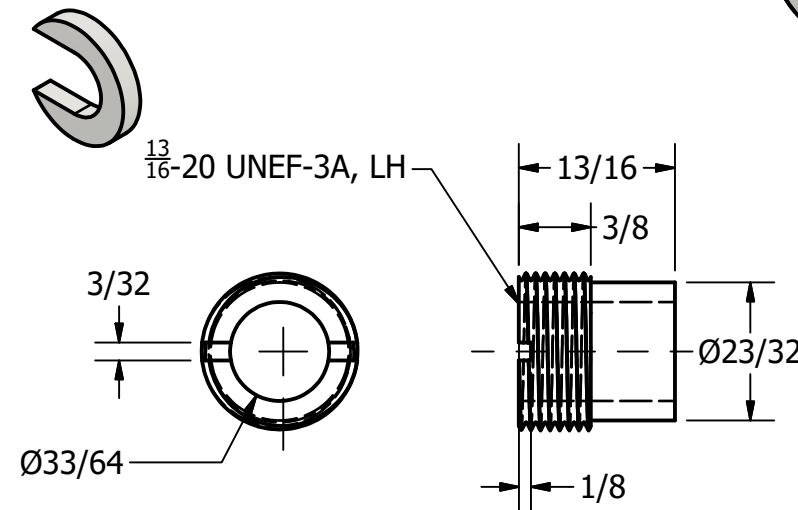

COLLAR
SCALE 1 : 1

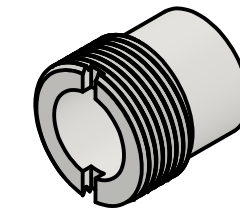

GENERAL NOTES:

ALL FILLETS AND ROUNDS R 1/8" UNLESS OTHERWISE STATED.

LEGEND:

- Ø DIAMETER
- R RADIUS
- ° DEGREES
- COUNTERBORE/ SPOTFACE
- ∇ COUNTERSINK
- ∇ DEPTH



DIGITAL DESIGN
GRAPHICS
TECHNOLOGY

WWW.DDGT.NET

LUIS RAMIREZ SOTO
GRAPHIC DESIGNER
707-302-4704
RAMIREZLUIS2020@OUTLOOK.COM

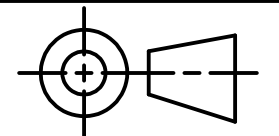

TOLERANCES UNLESS SPECIFIED:
DECIMAL INCHES
X = ±.020
XX = ±.010
XXX = ±.005
FRACTIONAL ±1/64"
ANGLES ±1 DEGREE
SURFACES 32

CLASS: DDGT240

ASSIGNMENT #: 38

INVENTOR DRAWING NAME:
MACHINE VISE

FIG #: 14-71

MANAGER: G. STROMMEN

DRAFTER: L. RAMIREZSOTO

DATE: 10/10/2024

SCALE: AS NOTED

PAGE #: 9 OF 9