

ENGINE BLOCK ASSEMBLY  
SCALE 1 / 2

PARTS LIST				
ITEM	QTY	PART NUMBER	MATERIAL	DESCRIPTION
1	1	ENGINE BLOCK	ALUMINUM	
2	1	CRANK SHAFT	STAINLESS STEEL	
3	3	PISTON	STAINLESS STEEL	
4	3	PISTON PIN	STAINLESS STEEL	
5	3	CONNECTING ROD	STAINLESS STEEL	
5.1	1	CONNECTING ROD TOP	STAINLESS STEEL	
5.2	1	CONNECTING ROD BOTTOM	STAINLESS STEEL	
5.3	1	SOCKET HEAD SCREW	ALLOY STEEL	91290A194_Alloy Steel Socket Head Screw

**METRIC**

**LEGEND:**

- ∅ DIAMETER
- R RADIUS
- ° DEGREES
- ∇ DEPTH

**GENERAL NOTES:**

ALL FILLETS AND ROUNDS R3 UNLESS OTHERWISE SPECIFIED



DIGITAL DESIGN  
GRAPHICS  
TECHNOLOGY

WWW.DDGT.NET

LUIS RAMIREZ SOTO  
GRAPHIC DESIGNER

707-302-4704

RAMIREZLUIS2020@OUTLOOK.COM

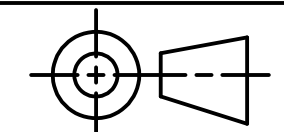

TOLERANCES UNLESS SPECIFIED:  
MILLIMETERS:  
WHOLE NUMBERS = ±.5  
XX = ±.25  
XXX = ±.12  
FRACTIONAL ±1/64"  
ANGLES ±1 DEGREE  
SURFACES <sup>32</sup>✓

CLASS: DDGT240

ASSIGNMENT #: 64

INVENTOR DRAWING NAME:  
ENGINE MODEL

FIG #: 20.69

MANAGER: G. STROMMEN

DRAFTER: L. RAMIREZSOTO

DATE: 10/29/2024

SCALE: AS NOTED

PAGE #: 1 OF 6

## GENERAL NOTES:

ALL FILLETS AND ROUNDS R3 UNLESS OTHERWISE SPECIFIED

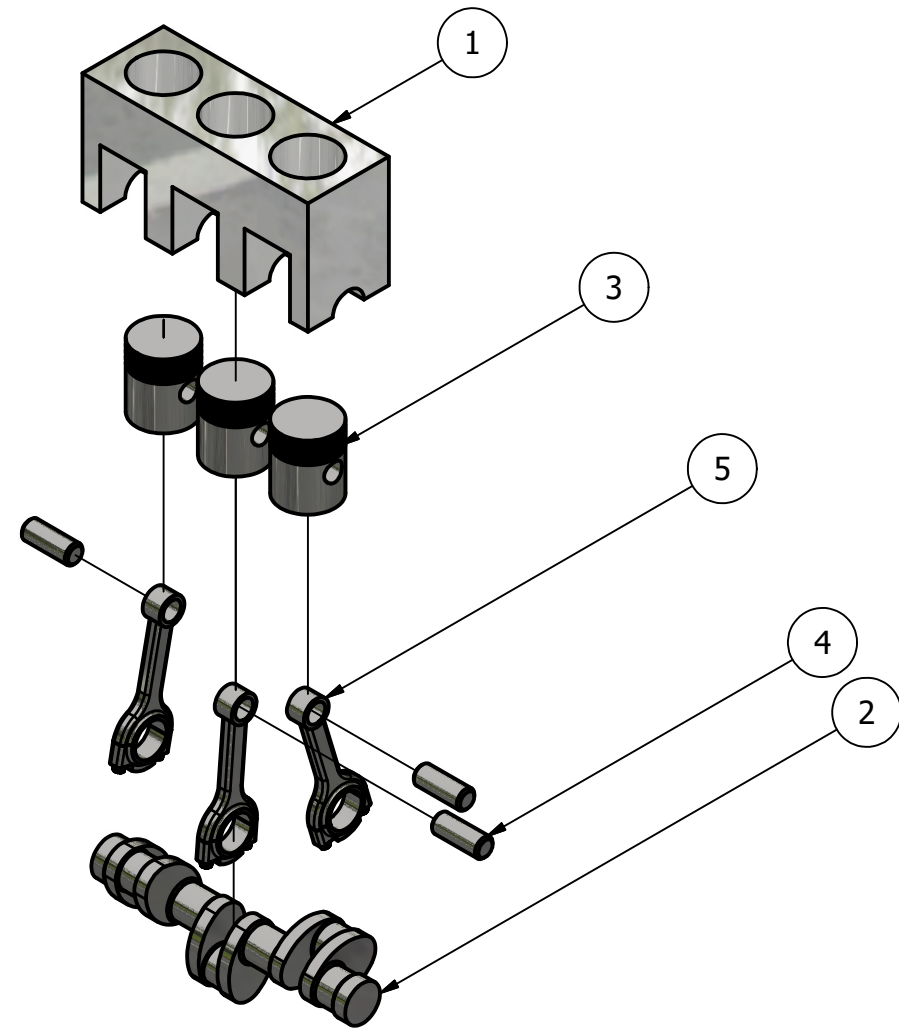

ENGINE MODEL EXPLODED ASSEMBLY  
SCALE 1/6

## LEGEND:

∅ DIAMETER  
R RADIUS  
° DEGREES  
∇ DEPTH

**METRIC**

PARTS LIST		
ITEM	QTY	PART NUMBER
1	1	ENGINE BLOCK
2	1	CRANK SHAFT
3	3	PISTON
4	3	PISTON PIN
5	3	CONNECTING ROD
5.1	1	CONNECTING ROD TOP
5.2	1	CONNECTING ROD BOTTOM
5.3	1	SOCKET HEAD SCREW

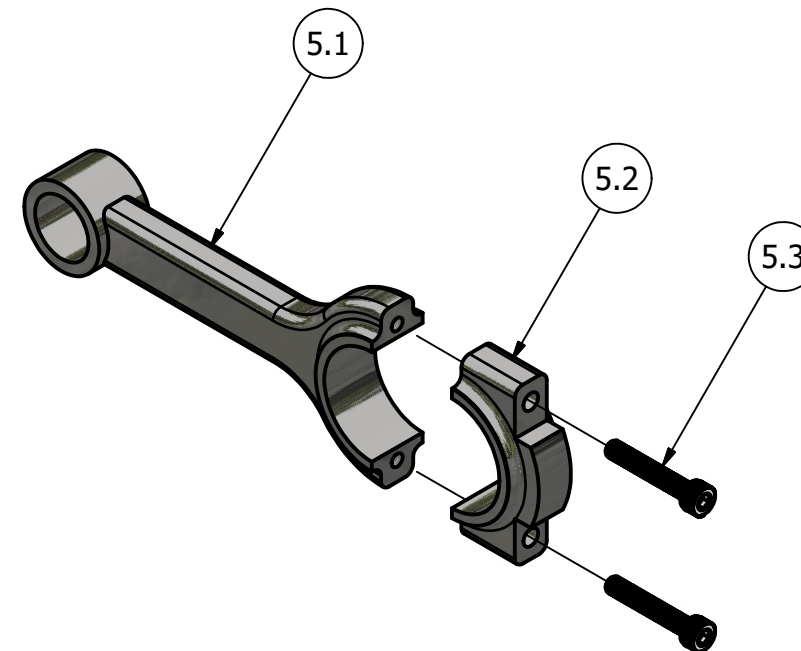

CONNECTING ROD EXPLODED ASSEMBLY  
SCALE 1 / 2

# DDGT

DIGITAL DESIGN  
GRAPHICS  
TECHNOLOGY

WWW.DDGT.NET

LUIS RAMIREZ SOTO  
GRAPHIC DESIGNER

707-302-4704

RAMIREZLUIS2020@OUTLOOK.COM

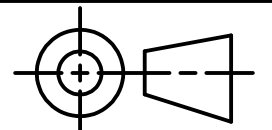

TOLERANCES UNLESS SPECIFIED:  
MILLIMETERS:  
WHOLE NUMBERS = ±.5  
XX = ±.25  
XXX = ±.12  
FRACTIONAL ±1/64"  
ANGLES ±1 DEGREE  
SURFACES <sup>32</sup>✓

CLASS: DDGT240

ASSIGNMENT #: 64

INVENTOR DRAWING NAME:  
ENGINE MODEL

FIG #: 20.69

MANAGER: G. STROMMEN

DRAFTER: L. RAMIREZSOTO

DATE: 10/29/2024

SCALE: AS NOTED

PAGE #: 2 OF 6

3X Ø60.1  
∇81

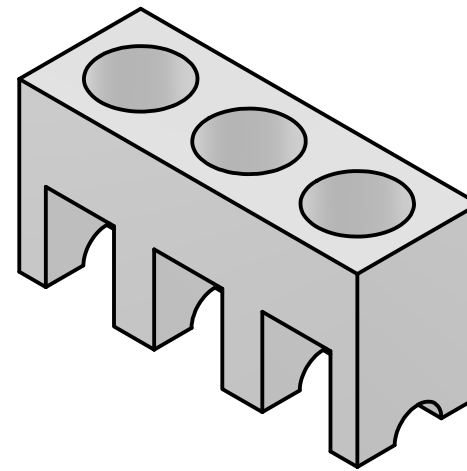
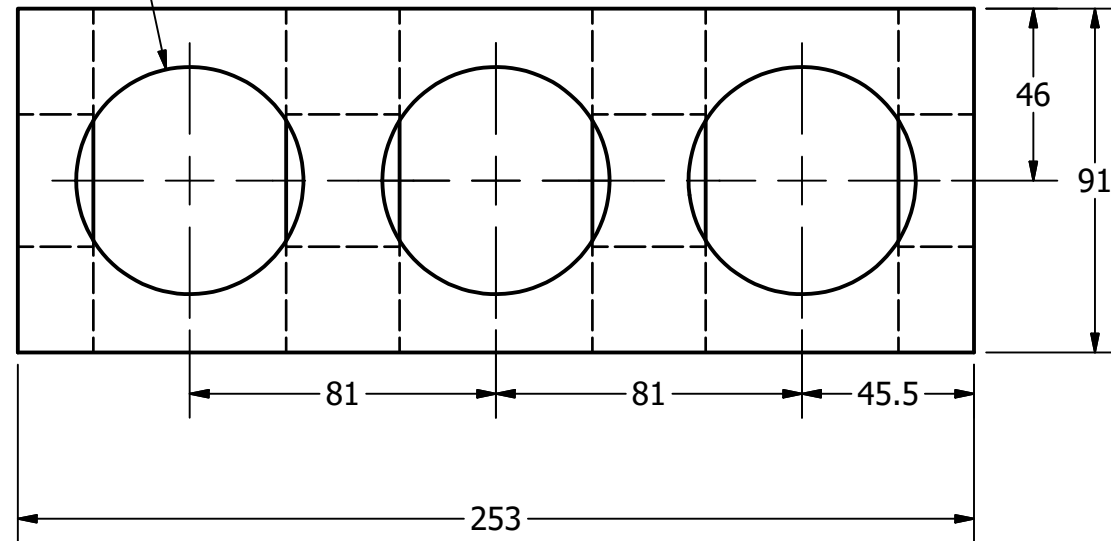

**LEGEND:**

- Ø DIAMETER
- R RADIUS
- ° DEGREES
- ∇ DEPTH

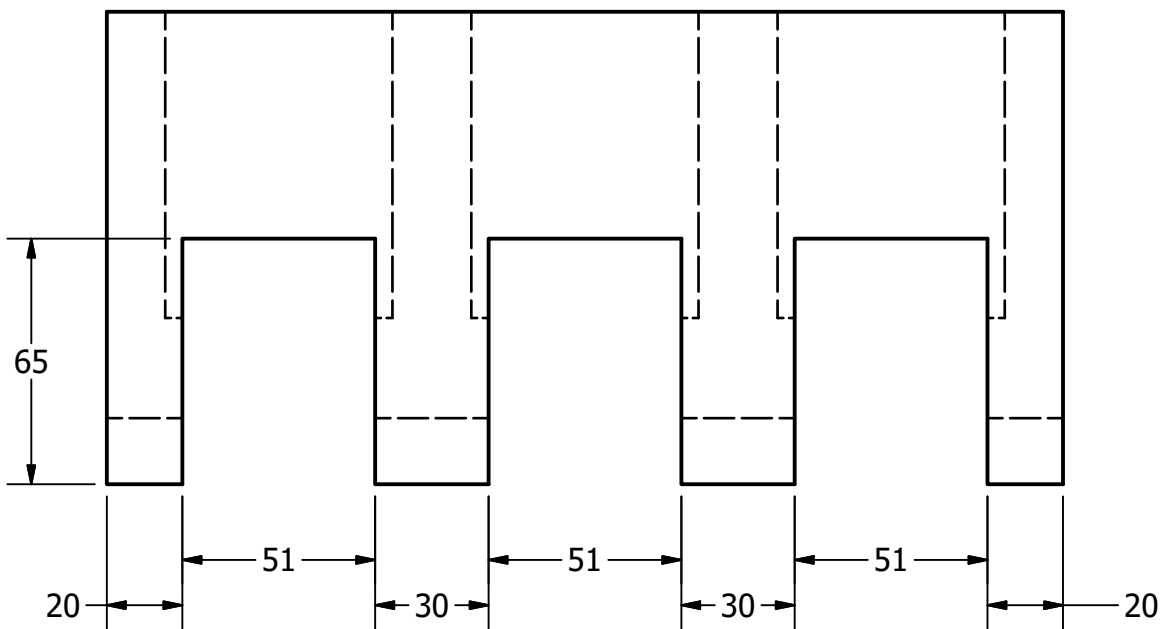

**ENGINE BLOCK**  
SCALE 1 / 2

**METRIC**

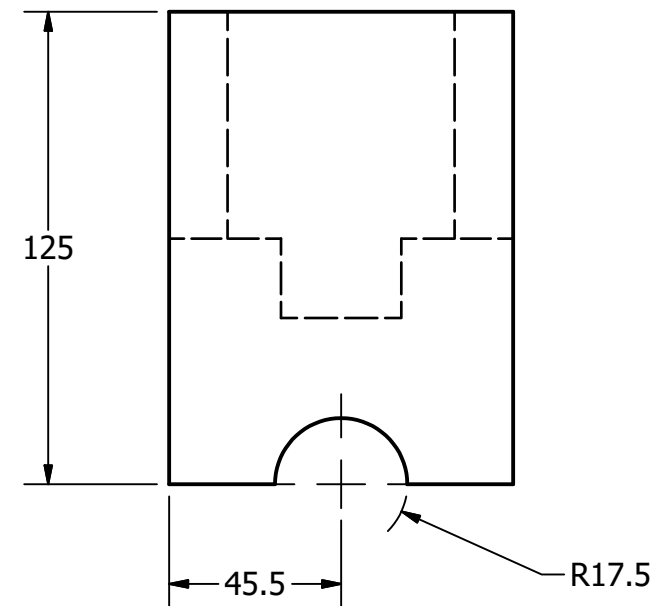

**GENERAL NOTES:**

ALL FILLETS AND ROUNDS R3 UNLESS OTHERWISE SPECIFIED

PARTS LIST		
ITEM	QTY	PART NUMBER
1	1	ENGINE BLOCK



DIGITAL DESIGN  
GRAPHICS  
TECHNOLOGY

WWW.DDGT.NET

LUIS RAMIREZ SOTO  
GRAPHIC DESIGNER

707-302-4704

RAMIREZLUIS202@OUTLOOK.COM

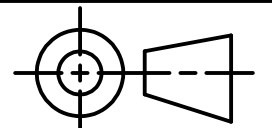

TOLERANCES UNLESS SPECIFIED:  
MILLIMETERS:  
WHOLE NUMBERS = ±.5  
XX = ±.25  
XXX = ±.12  
FRACTIONAL ±1/64"  
ANGLES ±1 DEGREE  
SURFACES <sup>32</sup>✓

CLASS: DDGT240

ASSIGNMENT #: 64

INVENTOR DRAWING NAME:  
**ENGINE MODEL**

FIG #: 20.69

MANAGER: G. STROMMEN

DRAFTER: L. RAMIREZSOTO

DATE: 10/29/2024

SCALE: AS NOTED

PAGE #: 3 OF 6

PARTS LIST		
ITEM	QTY	PART NUMBER
2	1	CRANK SHAFT



DIGITAL DESIGN  
GRAPHICS  
TECHNOLOGY

WWW.DDGT.NET

LUIS RAMIREZ SOTO  
GRAPHIC DESIGNER  
707-302-4704  
RAMIREZLUIS202@OUTLOOK.COM

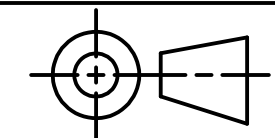

TOLERANCES UNLESS SPECIFIED:  
MILLIMETERS:  
WHOLE NUMBERS = ±.5  
XX = ±.25  
XXX = ±.12  
FRACTIONAL ±1/64"  
ANGLES ±1 DEGREE  
SURFACES  $\sqrt{32}$

CLASS: DDGT240

ASSIGNMENT #: 64

INVENTOR DRAWING NAME:  
ENGINE MODEL

FIG #: 20.69

MANAGER: G. STROMMEN

DRAFTER: L. RAMIREZSOTO

DATE: 10/29/2024

SCALE: AS NOTED

PAGE #: 4 OF 6

**LEGEND:**

- ∅ DIAMETER
- R RADIUS
- ° DEGREES
- ∇ DEPTH

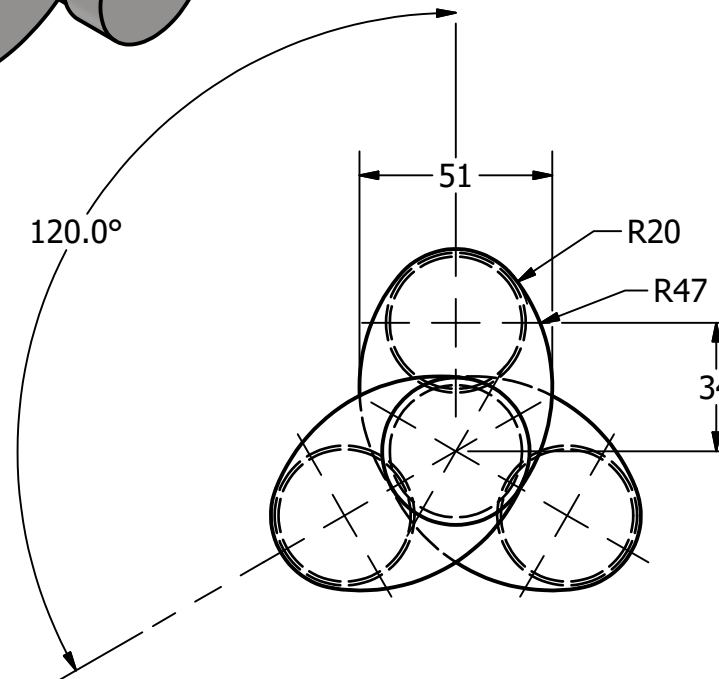
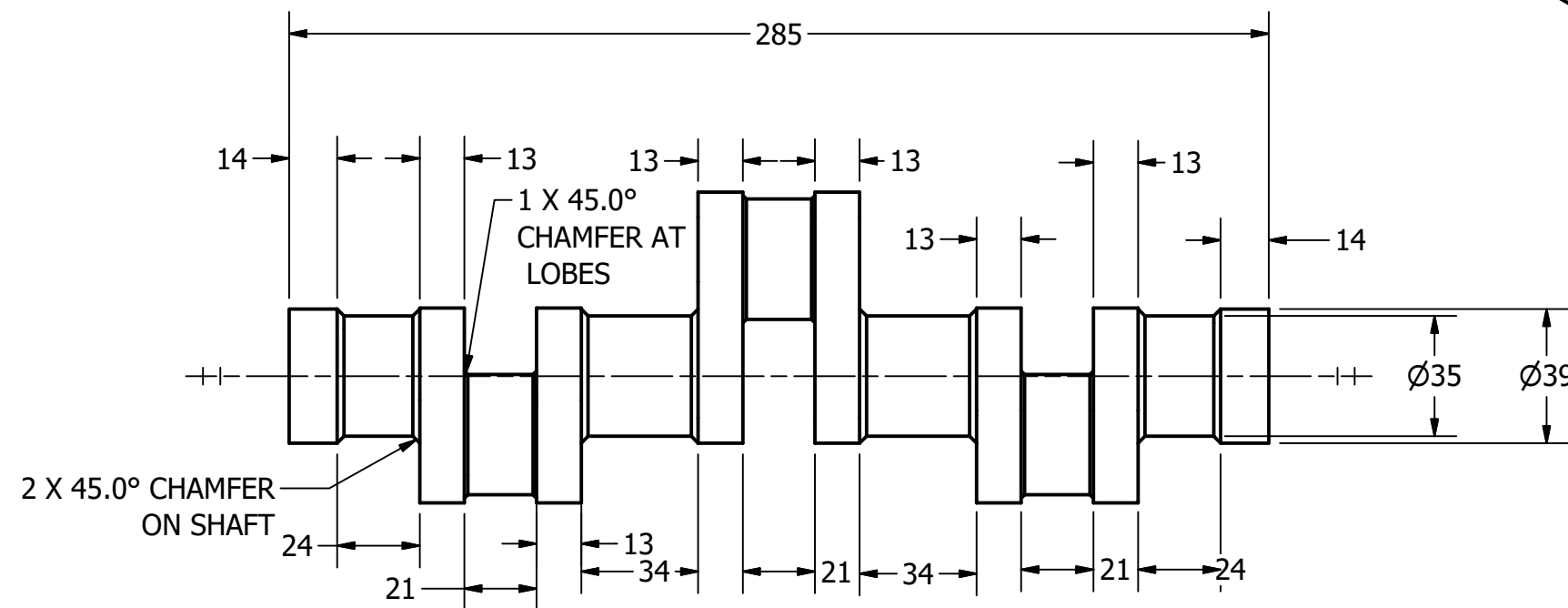
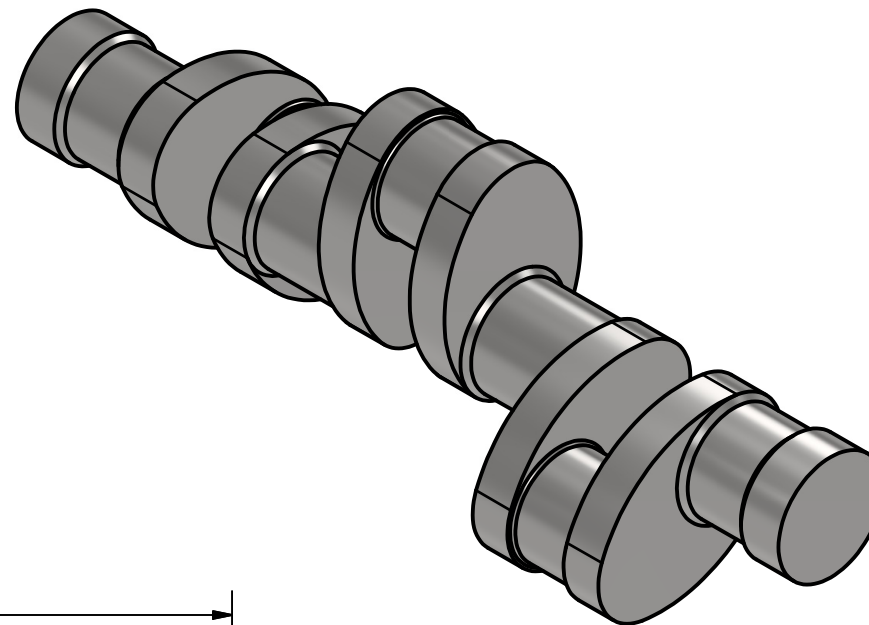

CRANK SHAFT  
SCALE 1 / 2

**METRIC**

**GENERAL NOTES:**

ALL FILLETS AND ROUNDS R3 UNLESS OTHERWISE SPECIFIED

**METRIC**

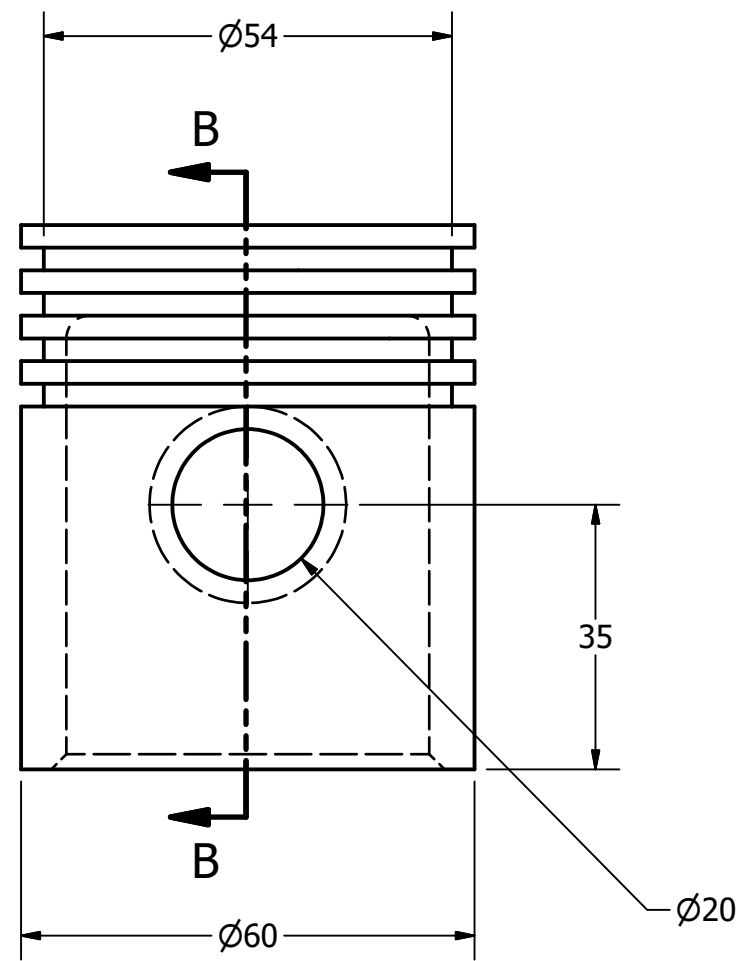
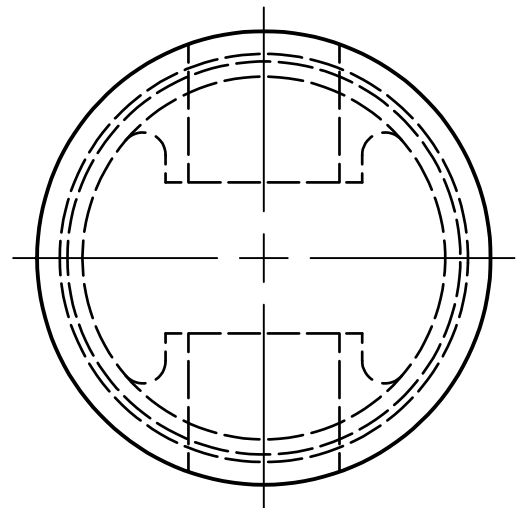

**PISTON  
SCALE 1 : 1**

**GENERAL NOTES:**  
ALL FILLETS AND ROUNDS R3 UNLESS OTHERWISE SPECIFIED

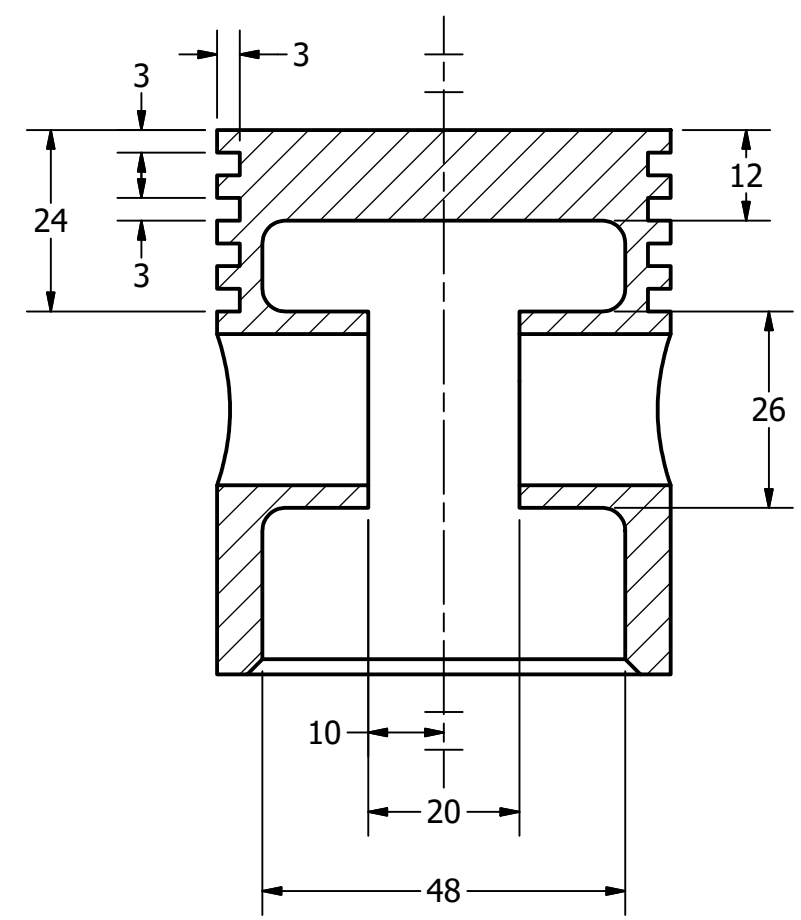

**SECTION B-B  
SCALE 1 : 1**

PARTS LIST		
ITEM	QTY	PART NUMBER
3	3	PISTON

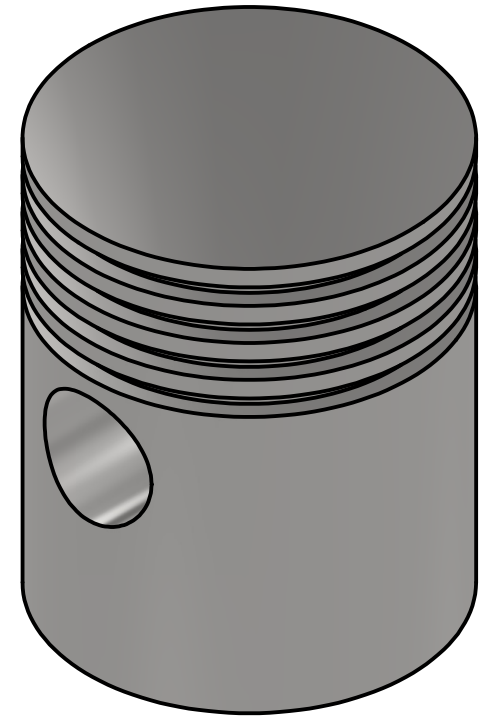

**LEGEND:**

- Ø DIAMETER
- R RADIUS
- ° DEGREES
- ∇ DEPTH



DIGITAL DESIGN  
GRAPHICS  
TECHNOLOGY

WWW.DDGT.NET

LUIS RAMIREZ SOTO  
GRAPHIC DESIGNER  
707-302-4704  
RAMIREZLUIS202@OUTLOOK.COM

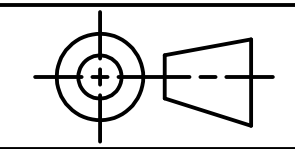

TOLERANCES UNLESS SPECIFIED:  
MILLIMETERS:  
WHOLE NUMBERS = ±.5  
XX = ±.25  
XXX = ±.12  
FRACTIONAL ±1/64"  
ANGLES ±1 DEGREE  
SURFACES <sup>32</sup>✓

CLASS: DDGT240

ASSIGNMENT #: 64

INVENTOR DRAWING NAME:  
**ENGINE MODEL**

FIG #: 20.69

MANAGER: G. STROMMEN

DRAFTER: L. RAMIREZSOTO

DATE: 10/29/2024

SCALE: AS NOTED

PAGE #: 5 OF 6

# LEGEND:

- ∅ DIAMETER
- R RADIUS
- ° DEGREES
- ∇ DEPTH

METRIC

PARTS LIST		
ITEM	QTY	PART NUMBER
4	3	PISTON PIN
5	3	CONNECTING ROD
5.1	1	CONNECTING ROD TOP
5.2	1	CONNECTING ROD BOTTOM
5.3	1	SOCKET HEAD SCREW

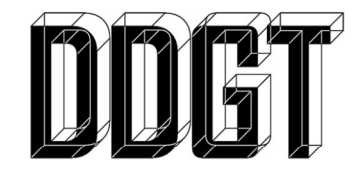

DIGITAL DESIGN  
GRAPHICS  
TECHNOLOGY

WWW.DDGT.NET

LUIS RAMIREZ SOTO  
 GRAPHIC DESIGNER  
 707-302-4704  
 RAMIREZLUIS202@OUTLOOK.COM

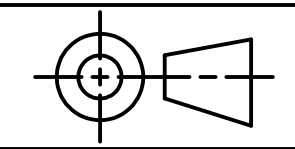

TOLERANCES UNLESS SPECIFIED:  
 MILLIMETERS:  
 WHOLE NUMBERS = ±.5  
                   XX = ±.25  
                   XXX = ±.12  
 FRACTIONAL ±1/64"  
 ANGLES ±1 DEGREE  
 SURFACES <sup>32</sup>✓

CLASS: DDGT240

ASSIGNMENT #: 64

INVENTOR DRAWING NAME:  
**ENGINE MODEL**

FIG #: 20.69

MANAGER: G. STROMMEN

DRAFTER: L. RAMIREZSOTO

DATE: 10/29/2024

SCALE: AS NOTED

PAGE #: 6 OF 6

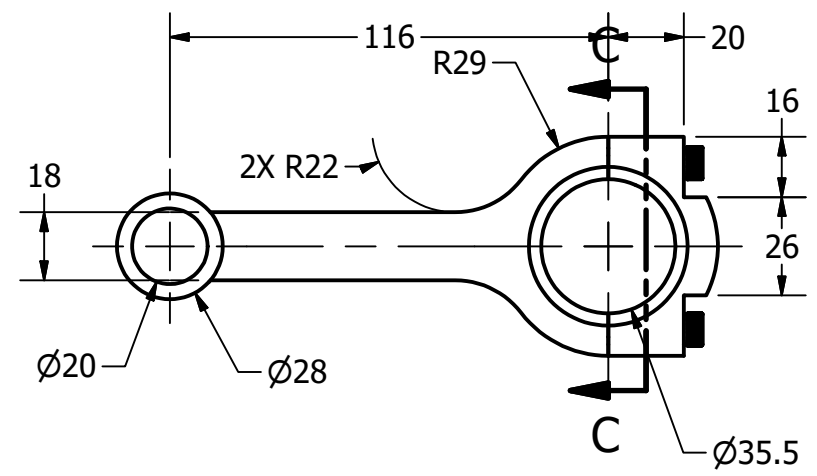
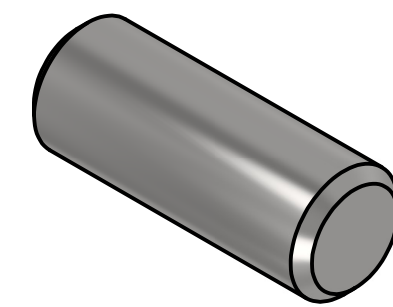
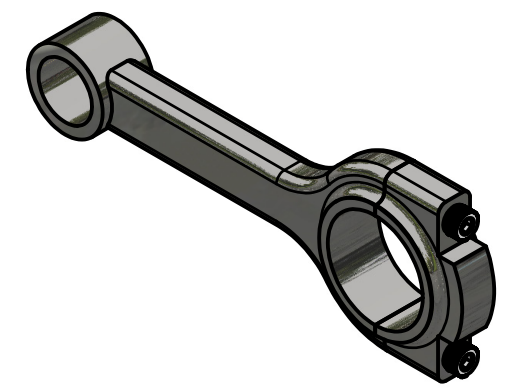
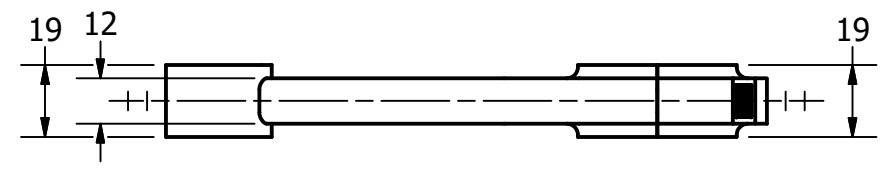

CONNECTING ROD  
SCALE 1 / 2

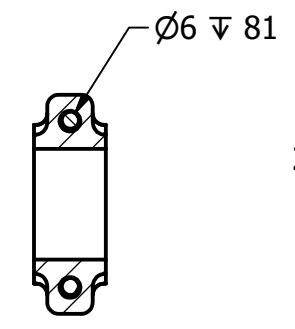

SECTION C-C  
SCALE 1 / 2

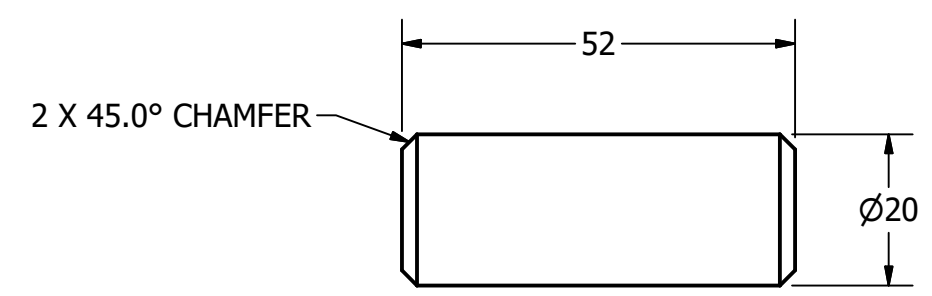

PISTON PIN  
SCALE 1 : 1

# GENERAL NOTES:

ALL FILLETS AND ROUNDS R3 UNLESS OTHERWISE SPECIFIED