

PARTS LIST					
ITEM	QTY	PART NUMBER	MATERIAL	DESCRIPTION	
1	1	POST	SAE 1112		
2	1	BRACKET	USS STEEL	13 GUAGE (2.38)	
3	1	SHAFT	SAE 1112		
4	1	WHEEL	HARD RUBBER		
5	1	BUSHING	BRASS		
6	1	RETAINING RING	STAINLESS STEEL	99179A105 - EXT SERIES 5133	

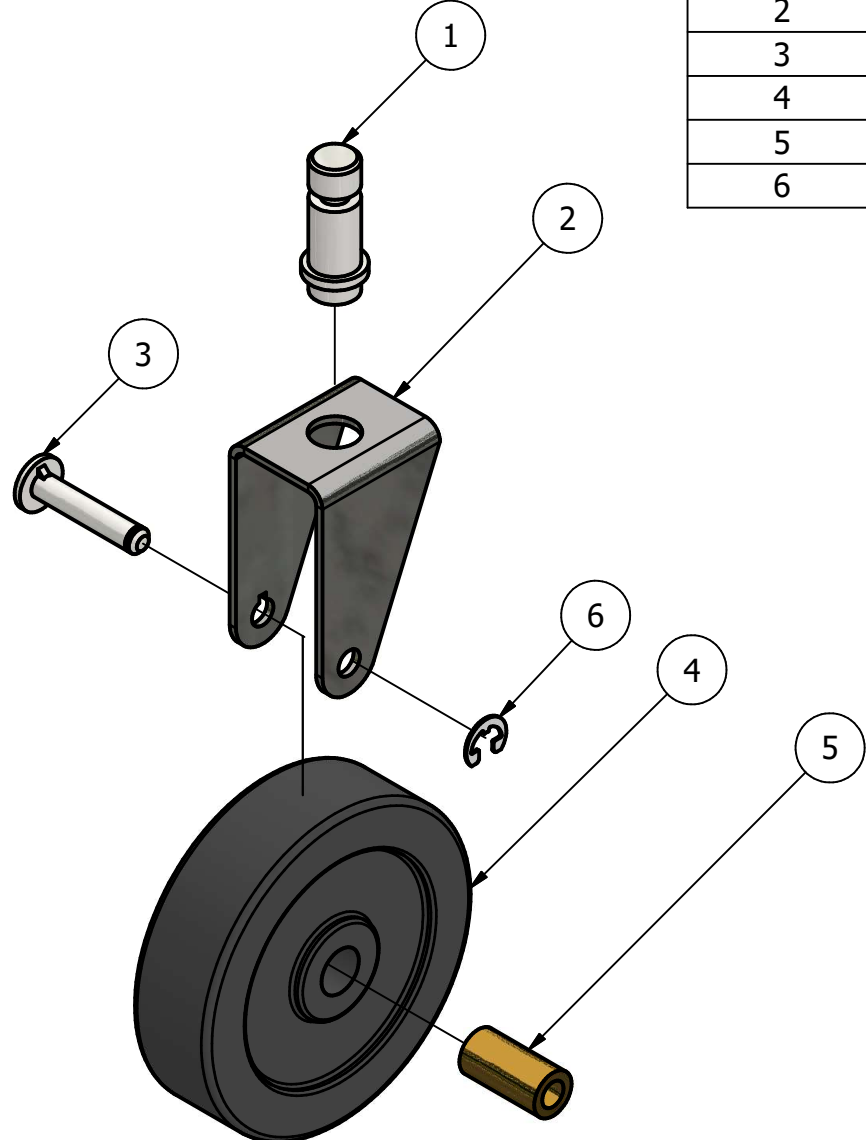

CASTER EXPLODED ASSEMBLY
SCALE 1 / 2

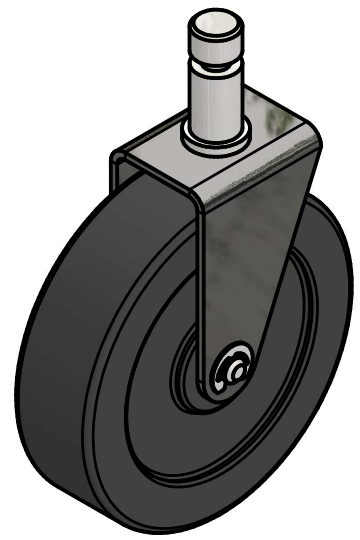

CASTER ASSEMBLY
SCALE 1 / 2

LEGEND:

- ∅ DIAMETER
- R RADIUS
- ° DEGREES

METRIC



DIGITAL DESIGN
GRAPHICS
TECHNOLOGY

WWW.DDGT.NET

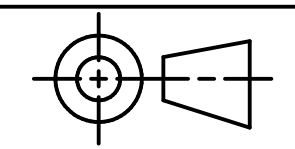

TOLERANCES UNLESS SPECIFIED:
MILLIMETERS:
WHOLE NUMBERS = ±.5
XX = ±.25
XXX = ±.12
FRACTIONAL ±1/64"
ANGLES ±1 DEGREE
SURFACES ³²✓

CLASS: DDGT 120

ASSIGNMENT #: 68

INVENTOR DRAWING NAME:
CASTER

FIG #: 14-90

MANAGER: G. STROMMEN

DRAFTER: LUISRS

DATE: 12/6/2023

SCALE: AS NOTED

PAGE #: 1 OF 4

PARTS LIST		
ITEM	QTY	PART NUMBER
1	1	POST
3	1	SHAFT

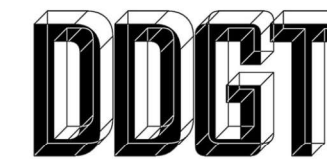

DIGITAL DESIGN
GRAPHICS
TECHNOLOGY

WWW.DDGT.NET

LEGEND:

- ∅ DIAMETER
- R RADIUS
- ° DEGREES

METRIC

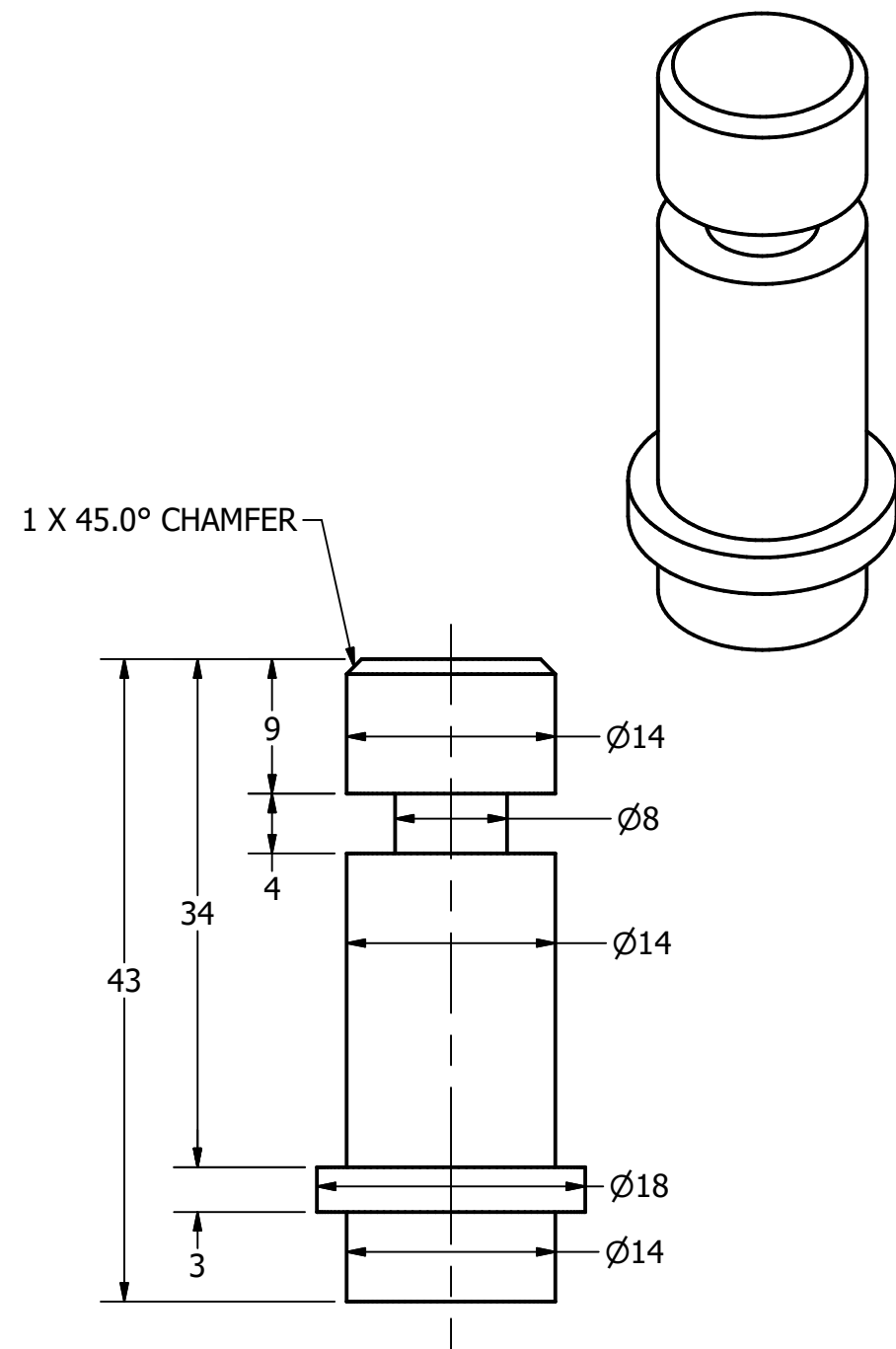

POST
SCALE 2 : 1

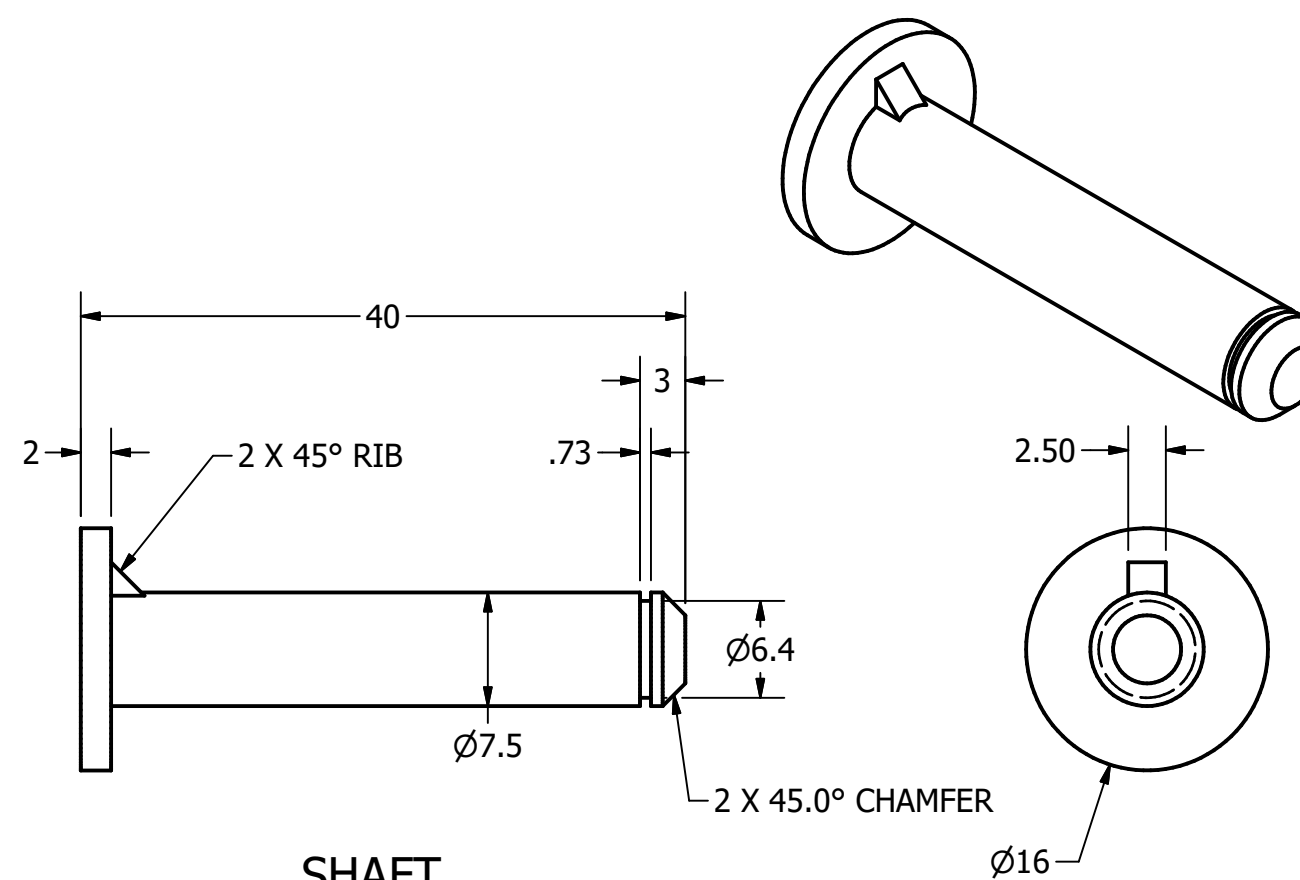

SHAFT
SCALE 2 : 1

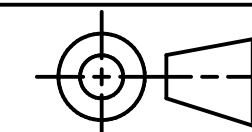

TOLERANCES UNLESS SPECIFIED:
MILLIMETERS:
WHOLE NUMBERS = ±.5
XX = ±.25
XXX = ±.12
FRACTIONAL ±1/64"
ANGLES ±1 DEGREE
SURFACES ³²✓

CLASS: DDGT 120

ASSIGNMENT #: 68

INVENTOR DRAWING NAME:
CASTER

FIG #: 14-90

MANAGER: G. STROMMEN

DRAFTER: LUISRS

DATE: 12/6/2023

SCALE: AS NOTED

PAGE #: 2 OF 4

METRIC

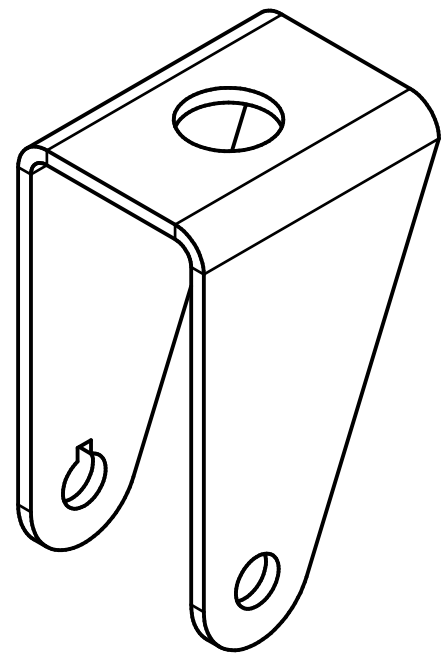

PARTS LIST		
ITEM	QTY	PART NUMBER
2	1	BRACKET

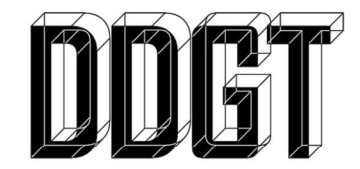

DIGITAL DESIGN
GRAPHICS
TECHNOLOGY

WWW.DDGT.NET

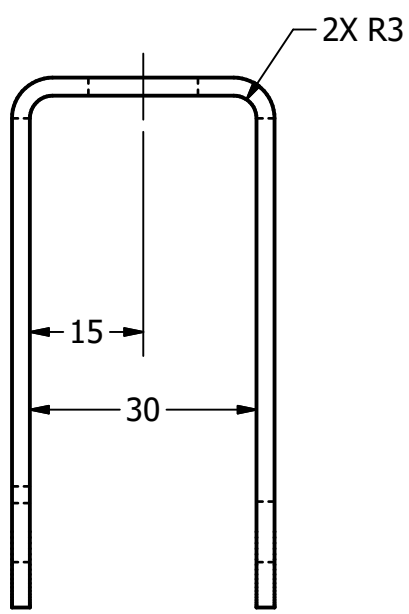

BRACKET FOLDED
SCALE 1 : 1

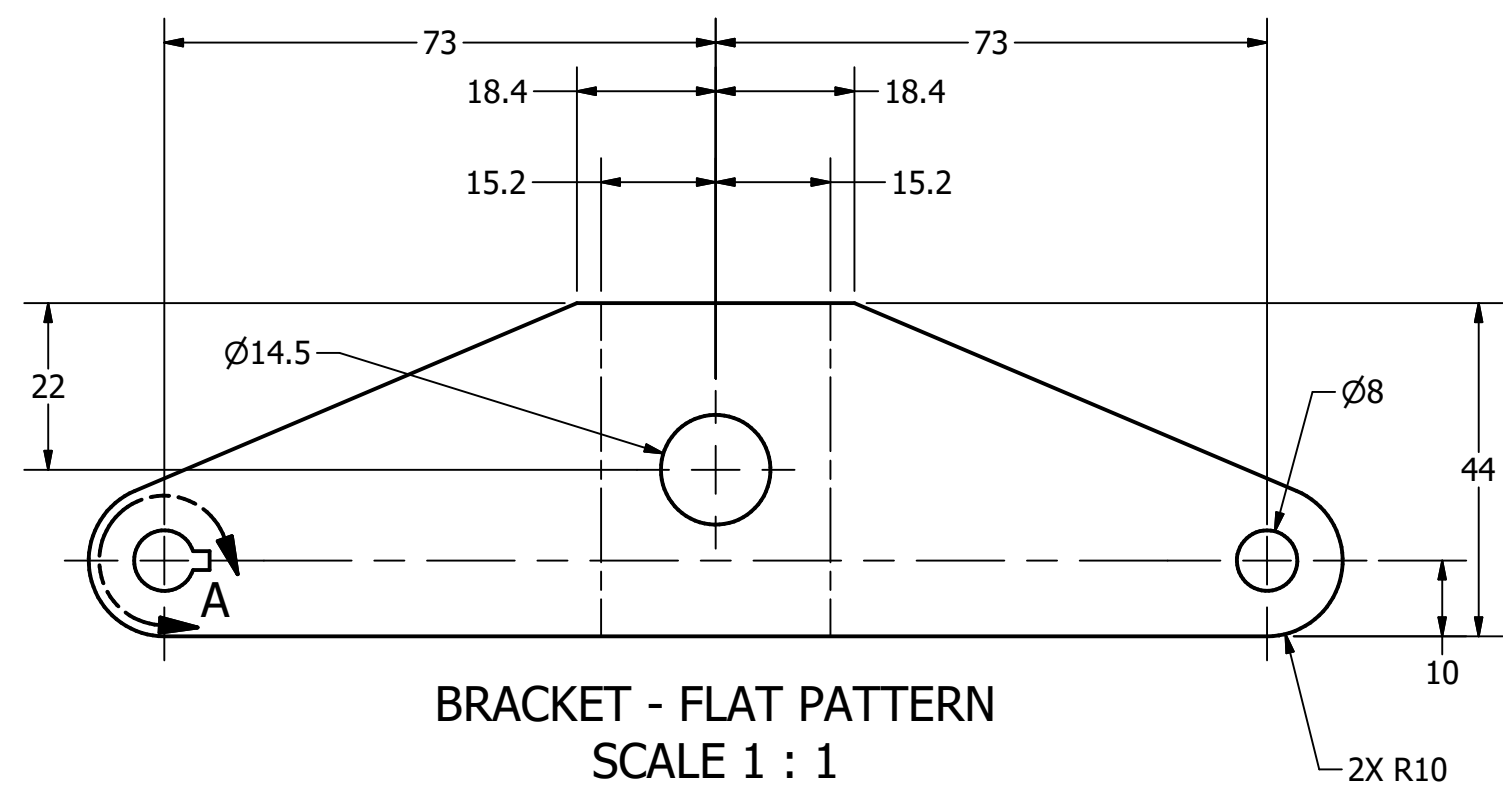
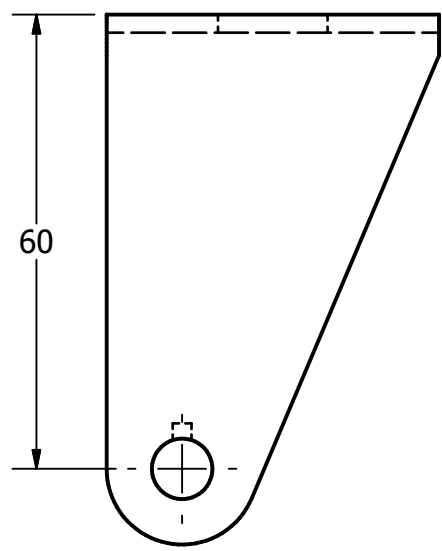

BRACKET - FLAT PATTERN
SCALE 1 : 1

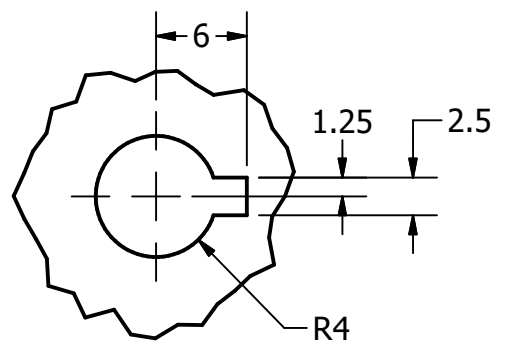

DETAIL A
SCALE 2 : 1

LEGEND:

- Ø DIAMETER
- R RADIUS
- ° DEGREES

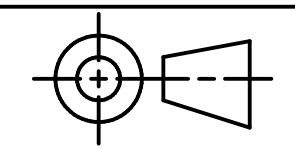

TOLERANCES UNLESS SPECIFIED:
MILLIMETERS:
WHOLE NUMBERS = ±.5
XX = ±.25
XXX = ±.12
FRACTIONAL ±1/64"
ANGLES ±1 DEGREE
SURFACES ³²✓

CLASS: DDGT 120

ASSIGNMENT #: 68

INVENTOR DRAWING NAME:
CASTER

FIG #: 14-90

MANAGER: G. STROMMEN

DRAFTER: LUISRS

DATE: 12/6/2023

SCALE: AS NOTED

PAGE #: 3 OF 4

METRIC

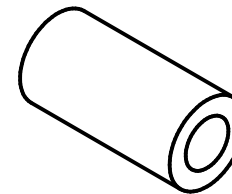
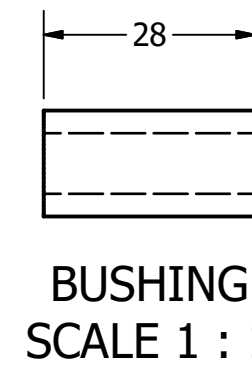
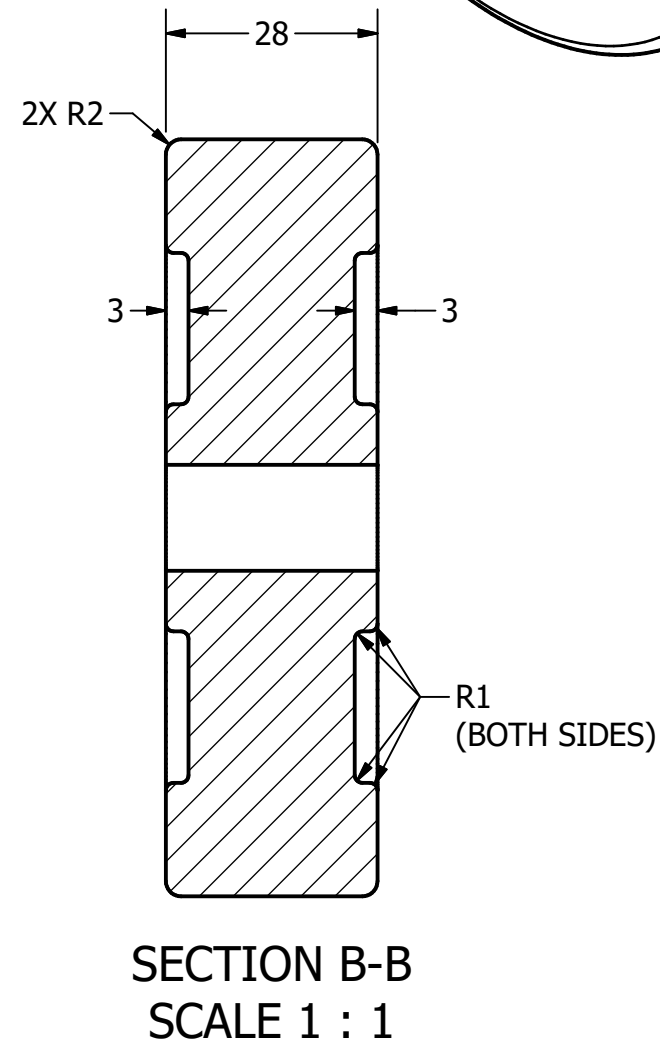
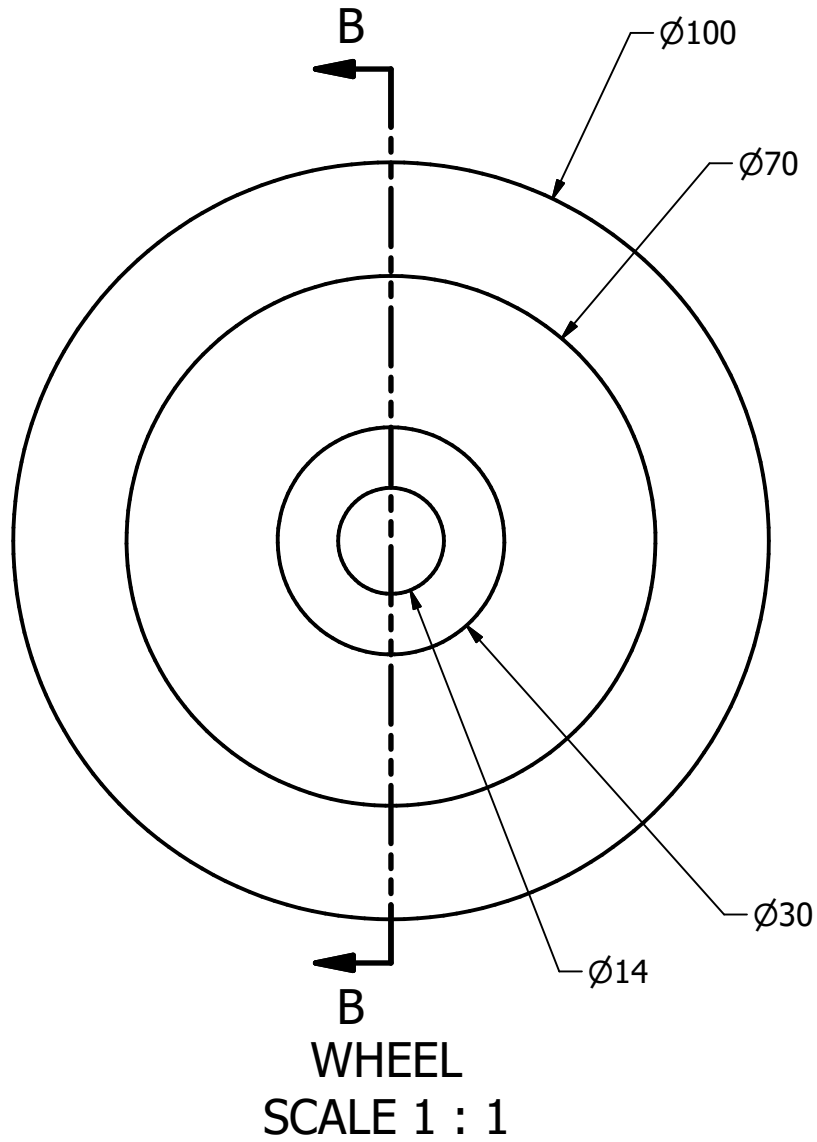
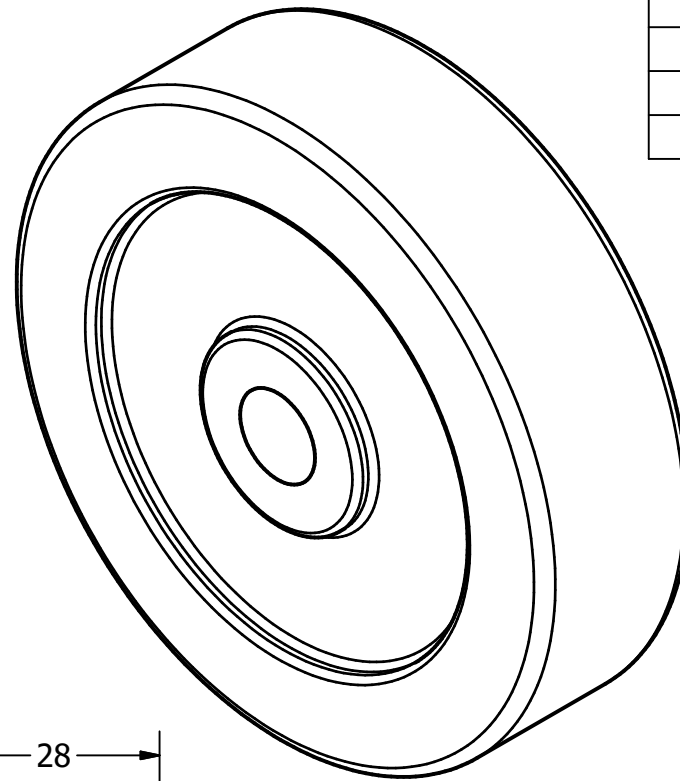

LEGEND:

- Ø DIAMETER
- R RADIUS
- ° DEGREES

PARTS LIST		
ITEM	QTY	PART NUMBER
4	1	WHEEL
5	1	BUSHING



DIGITAL DESIGN
GRAPHICS
TECHNOLOGY

WWW.DDGT.NET

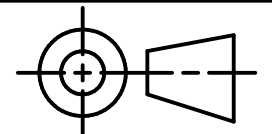

TOLERANCES UNLESS SPECIFIED:
MILLIMETERS:
WHOLE NUMBERS = ±.5
XX = ±.25
XXX = ±.12
FRACTIONAL ±1/64"
ANGLES ±1 DEGREE
SURFACES ³²✓

CLASS: DDGT 120

ASSIGNMENT #: 68

INVENTOR DRAWING NAME:
CASTER

FIG #: 14-90

MANAGER: G. STROMMEN

DRAFTER: LUISRS

DATE: 12/6/2023

SCALE: AS NOTED

PAGE #: 4 OF 4