

GENERAL NOTES:
FILLETS & ROUNDS 1/8 R
UNLESS OTHERWISE
SPECIFIED

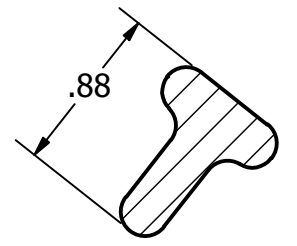

SECTION D-D
SCALE 1 / 1

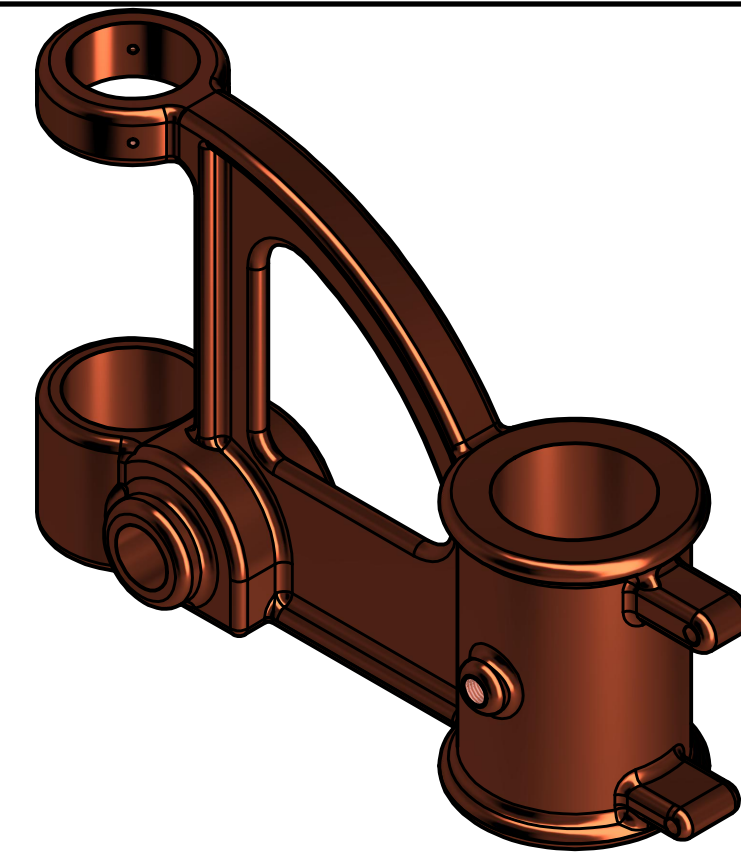
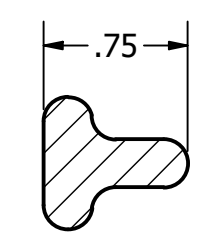

SECTION C-C
SCALE 1 / 1

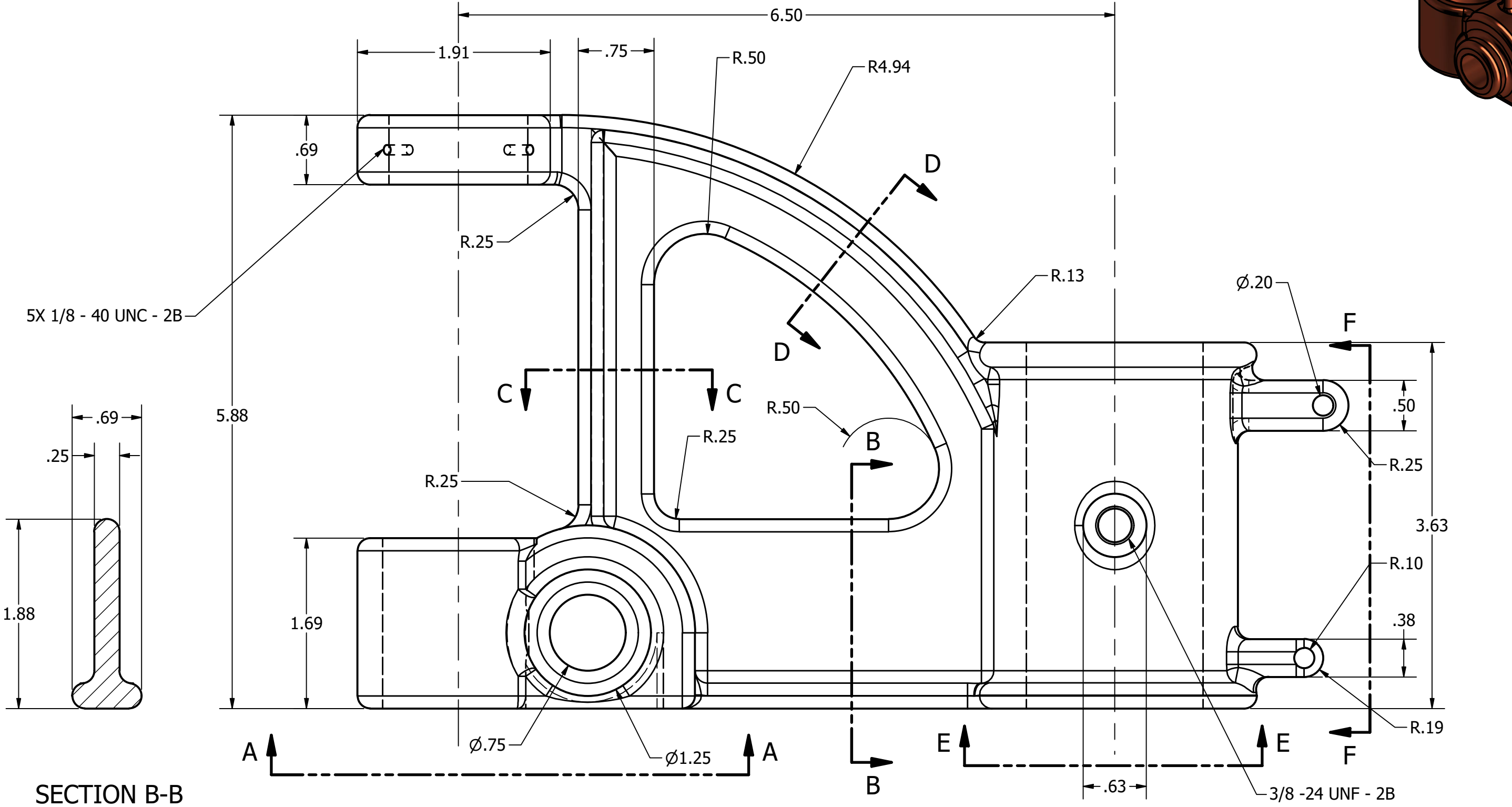

DRILL PRESS BRACKET
SCALE 1 / 1

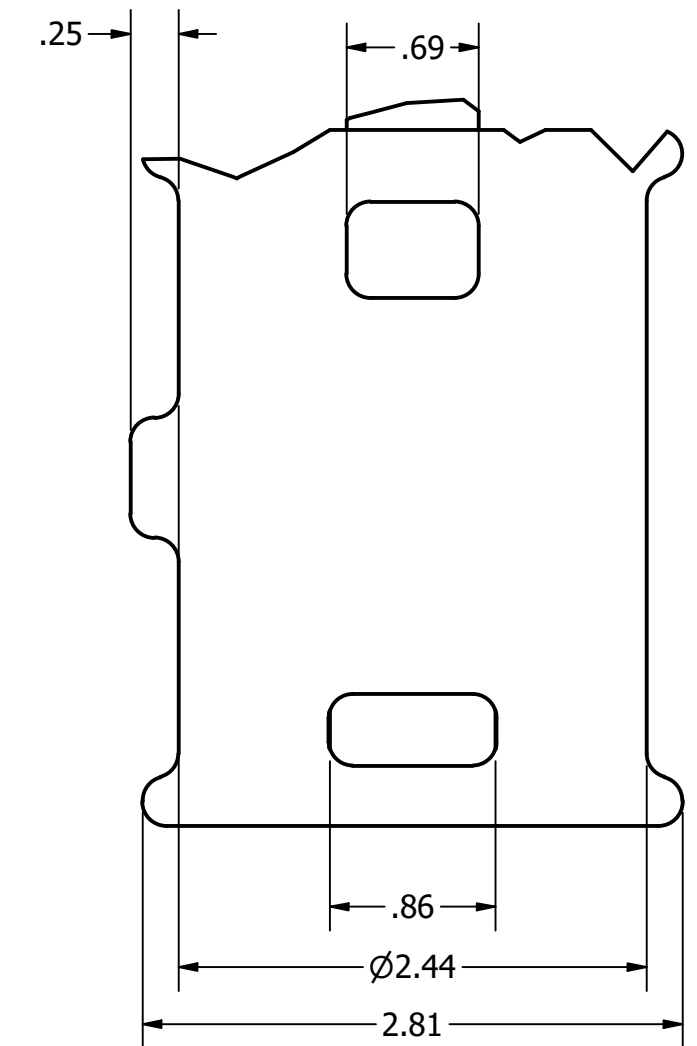

VIEW F-F
SCALE 1 / 1

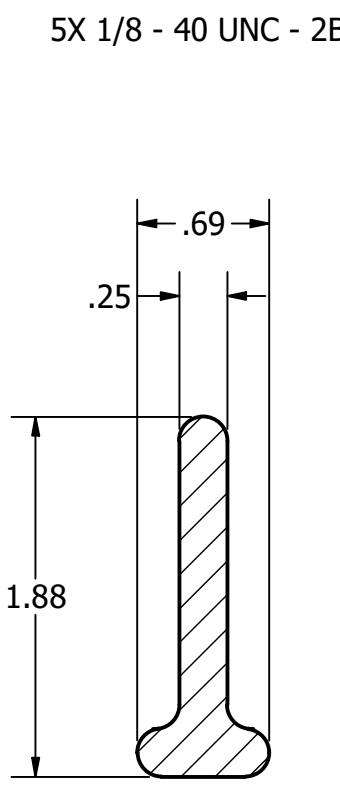

SECTION B-B
SCALE 1 / 1

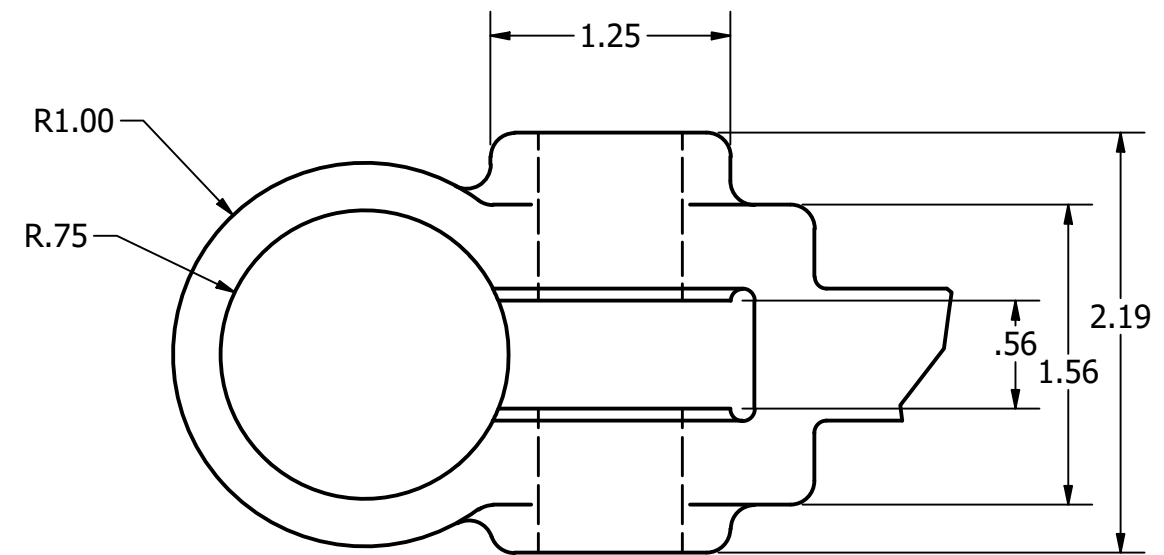

VIEW A-A
SCALE 1 / 1

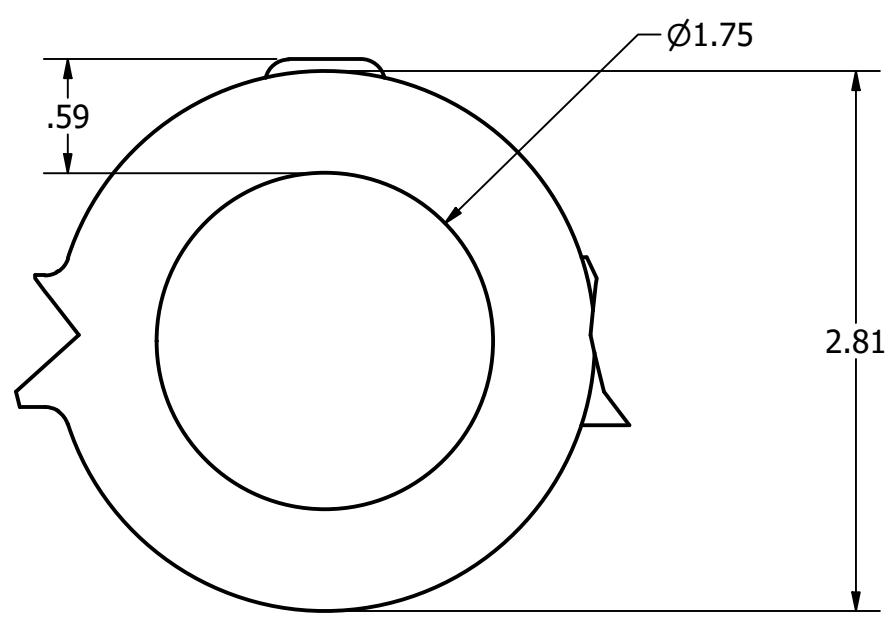

VIEW E-E
SCALE 1 / 1

LEGEND:

- Ø DIAMETER
- R RADIUS
- ° DEGREES

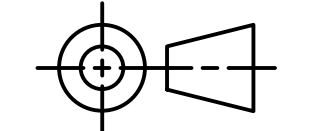

TOLERANCES UNLESS SPECIFIED:
DECIMAL INCHES:
X = ±.020
XX = ±.010
XXX = ±.005
FRACTIONAL ±1/64"
ANGLES ±1 DEGREE
SURFACES ³²✓

CLASS: DDGT120

ASSIGNMENT #: 36

INVENTOR DRAWING NAME:
Drill Press Bracket

FIG #: FIG #14-35

MANAGER: G. STROMMEN

DRAFTER: M. KENNING

DATE: 5/22/2024

SCALE: AS NOTED

PAGE #: 1 OF 1