

PARTS LIST			
ITEM	QTY	PART NUMBER	MATERIAL
1	1	DRILL PRESS BRACKET	Default

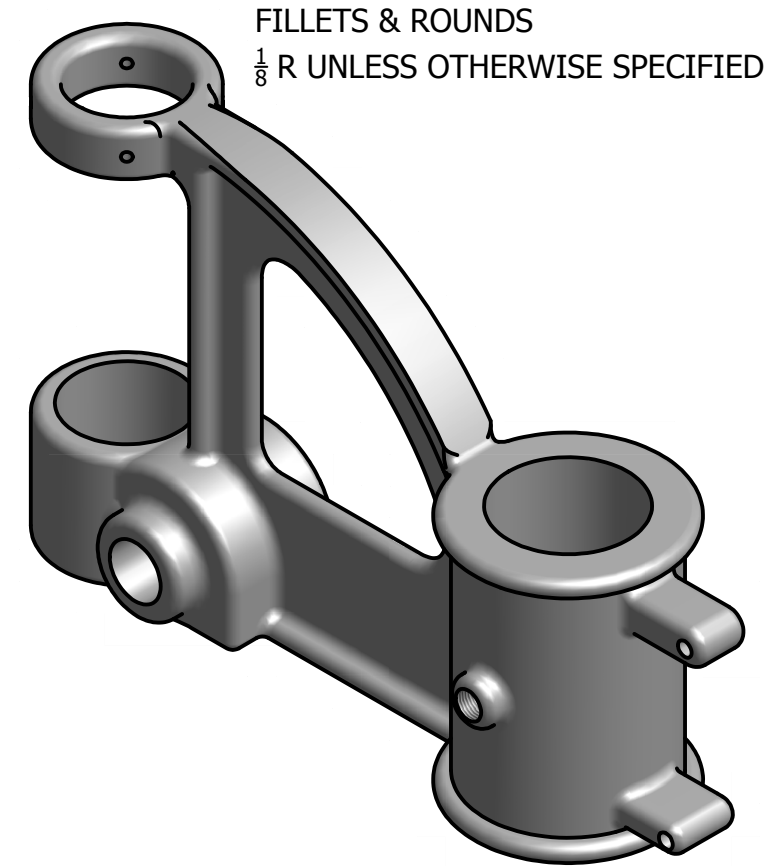
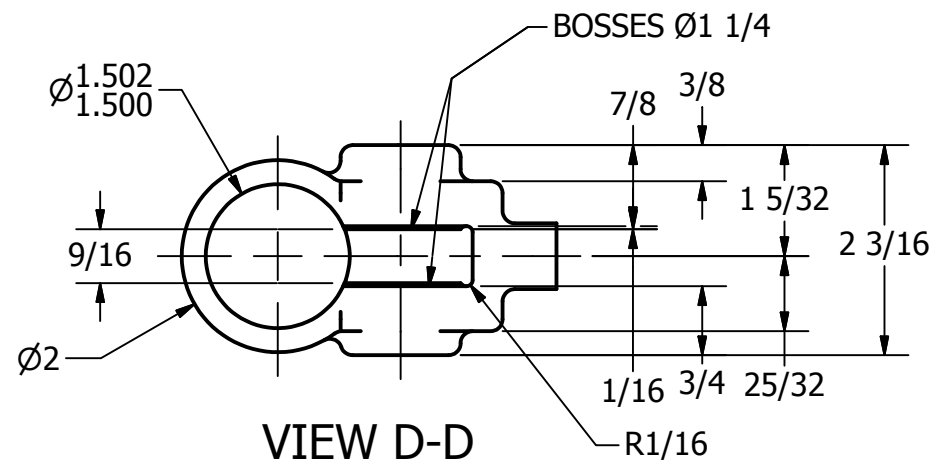
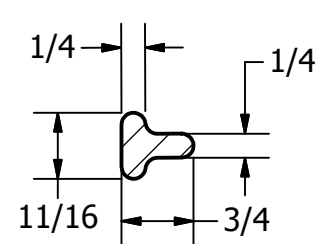
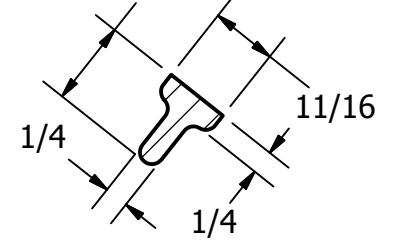
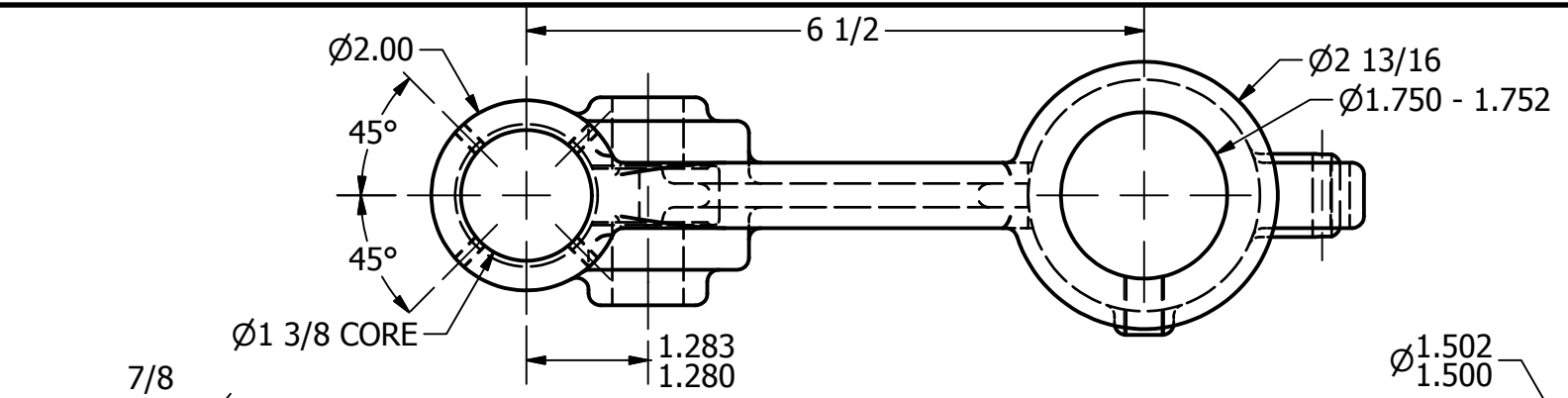

SECTION A-A
SCALE 1 : 2

SECTION B-B
SCALE 1 : 2

VIEW D-D
SCALE 1 : 2

DRILL PRESS BRACKET
SCALE 1 : 2

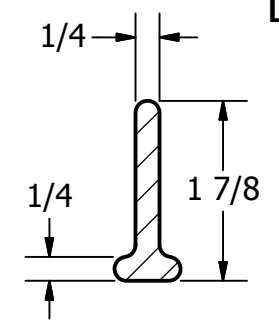
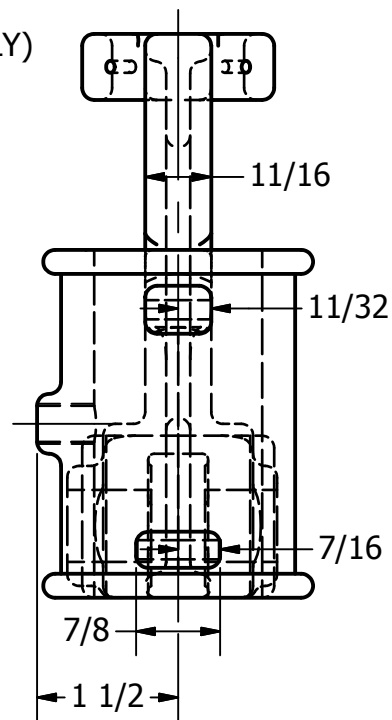
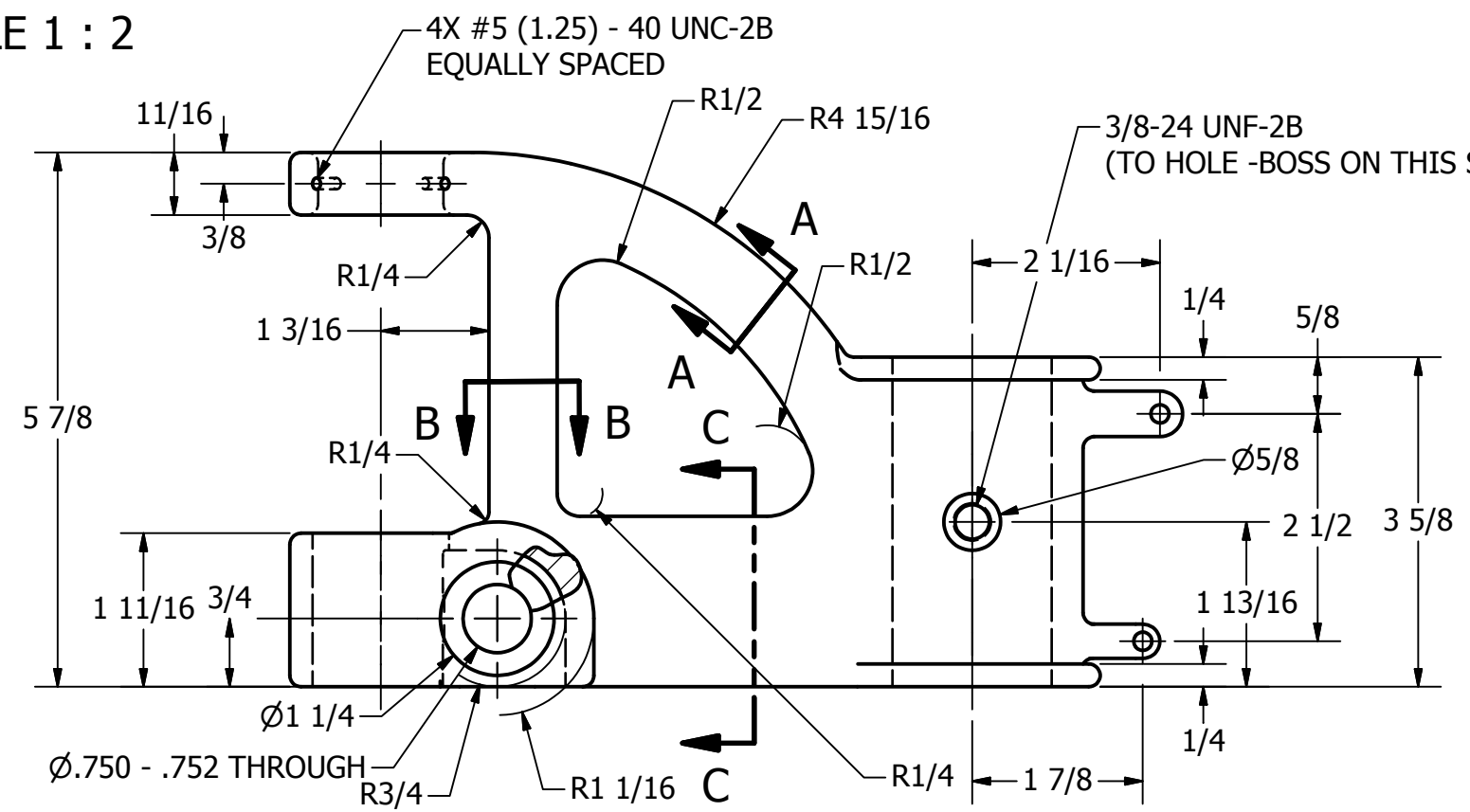

SECTION C-C
SCALE 1 : 2

LEGEND
°=ANGLE
Ø=DIAMETER
R=RADIUS

DRILL PRESS BRACKET
SCALE 1 : 2



DIGITAL DESIGN GRAPHICS TECHNOLOGY	NAME	MQUEVEDO	DWG NAME:	14-35	SHEET#:	1 OF 1
	COURSE:	DDGT 120		DRILL PRESS BRACKET		
	DATE:	12/5/2011	SCALE:	AS NOTED		