

PARTS LIST			
ITEM	QTY	PART NUMBER	MATERIAL
1	1	BRACKET	13 GA (2.38) USS STL
2	1	BUSHING	BRASS
3	1	WHEEL	HARD RUBBER
4	1	SHAFT	SAE 1112
5	1	POST	SAE 1112
6	1	RETAINING RING EXT SERIES 5133	STEEL

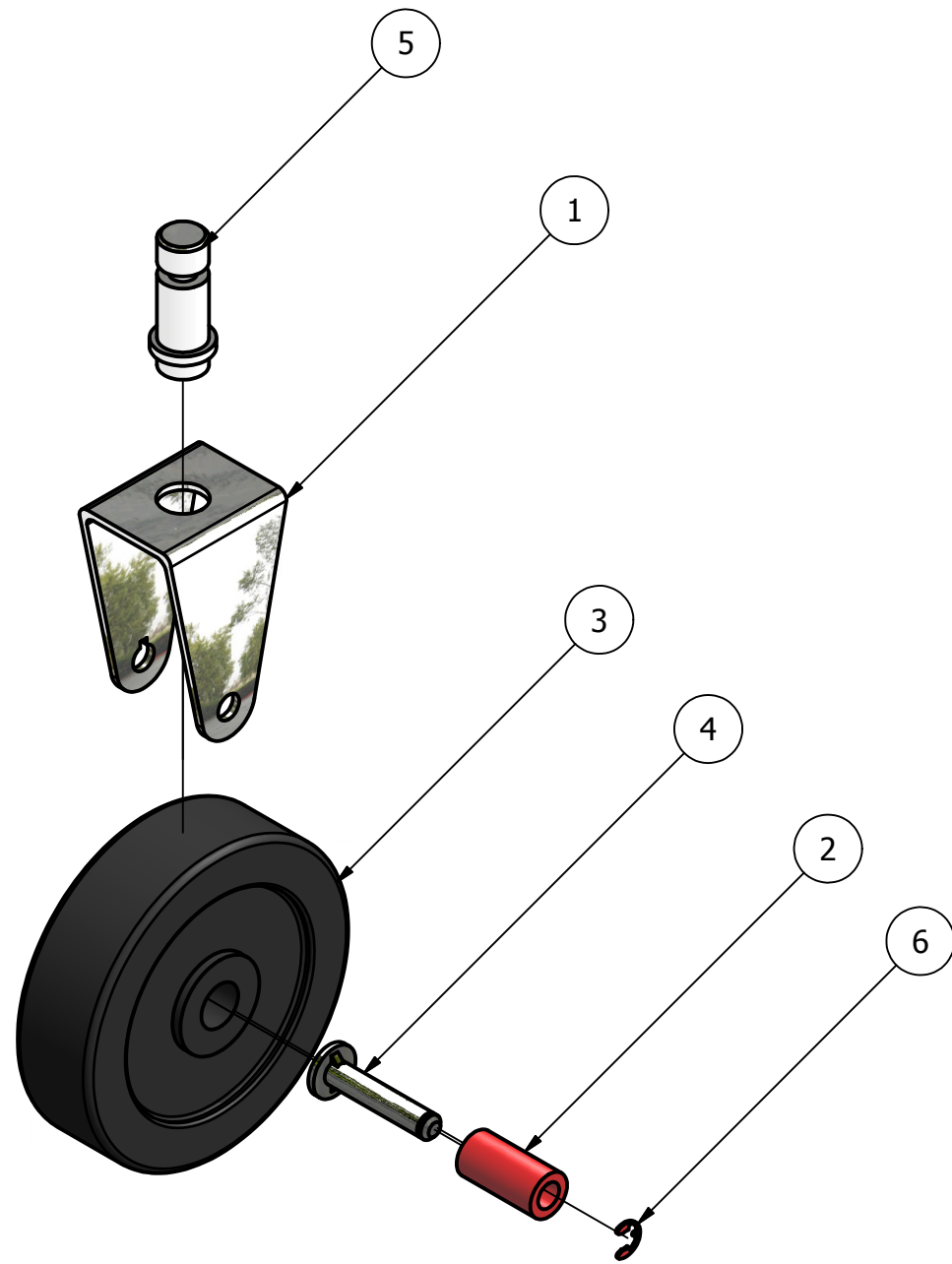

CASTER ASSEMBLY EXPLODED VIEW  
SCALE 1 / 2

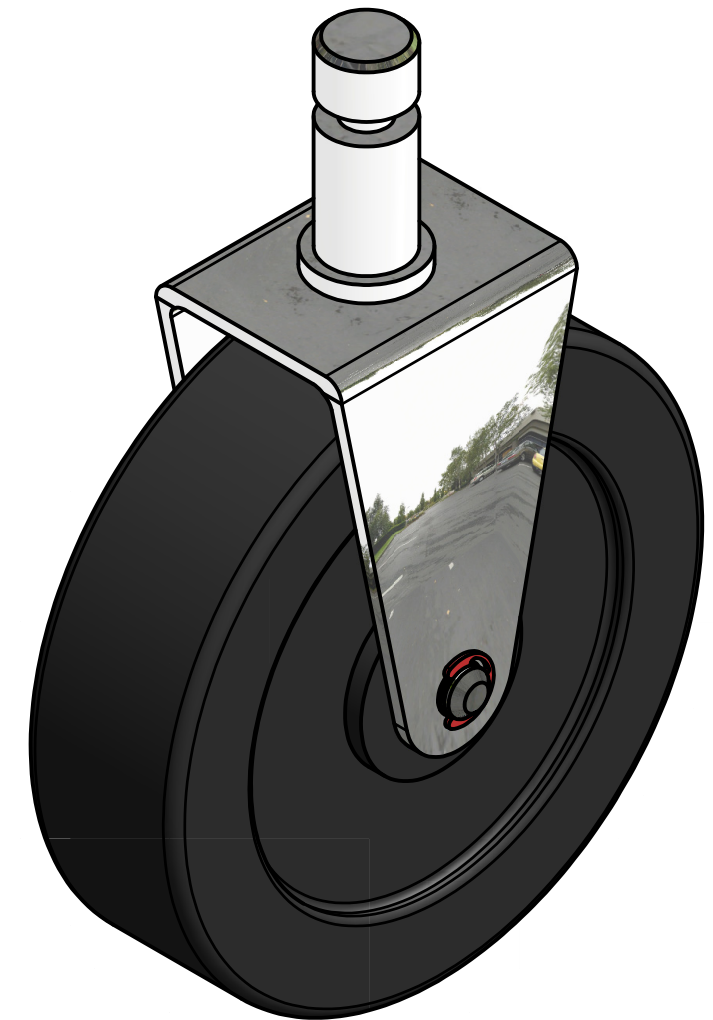

CASTER ASSEMBLY  
SCALE 1 : 1

DIGITAL DESIGN GRAPHICS TECHNOLOGY	NAME	MQUEVEDO	DWG NAME:	14-90 CASTER	SHEET#:	1 OF 2
	COURSE:	DDGT 122	SCALE:	AS NOTED		
	DATE:	5/16/2012				

PARTS LIST		
ITEM	QTY	PART NUMBER
1	1	BRACKET
2	1	BUSHING
3	1	WHEEL
4	1	SHAFT
5	1	POST

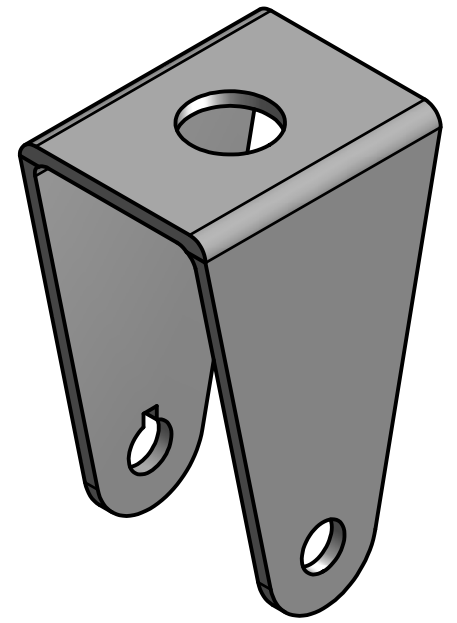

BRACKET  
SCALE 1 : 1

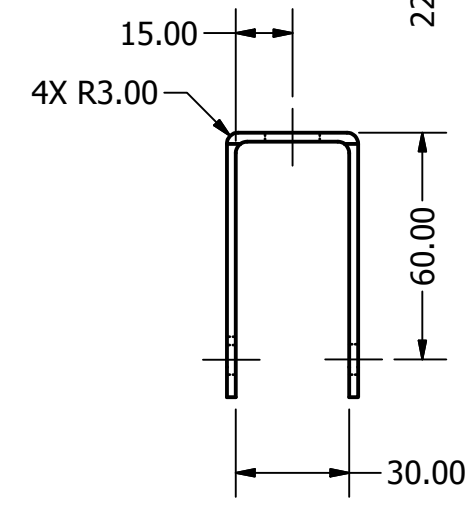
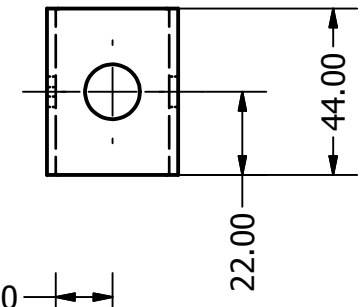

BRACKET  
SCALE 1 / 2

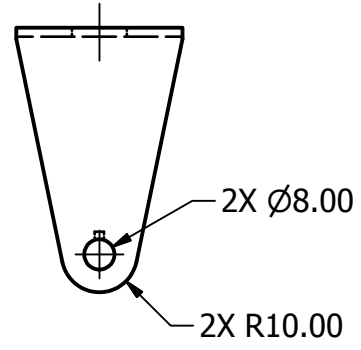
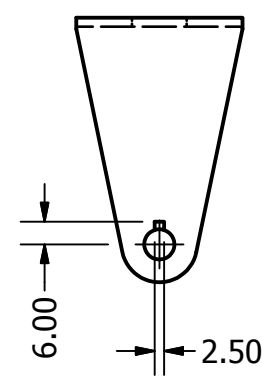

BRACKET METAL PLATE THICKNESS 2.38 MM

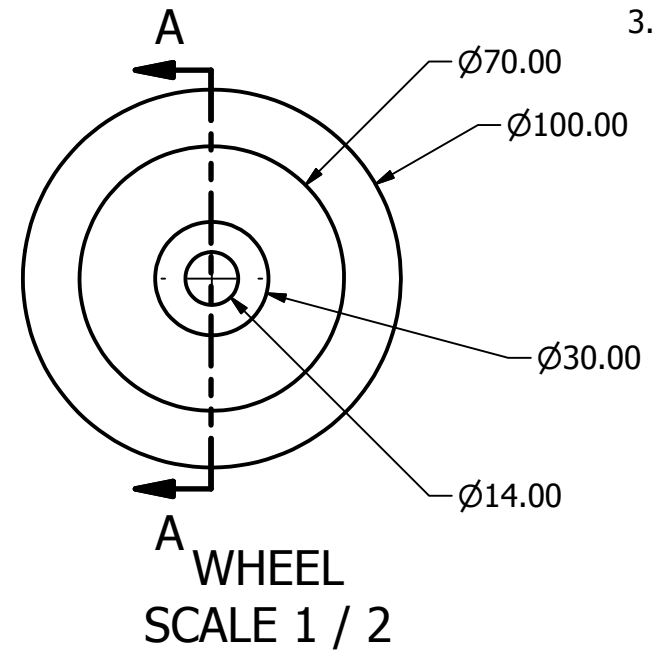

WHEEL  
SCALE 1 / 2

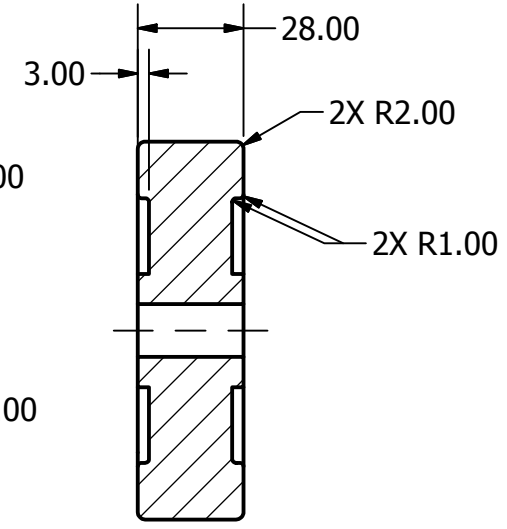

SECTION A-A  
SCALE 1 / 2

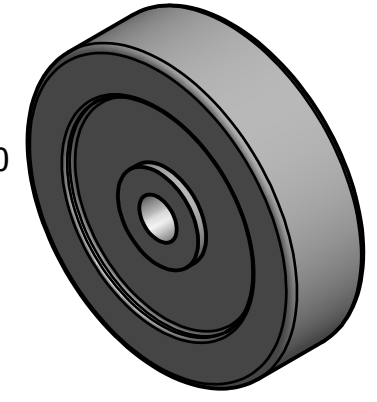

WHEEL  
SCALE 1 : 2

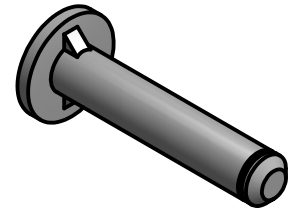

SHAFT  
SCALE 1 : 1

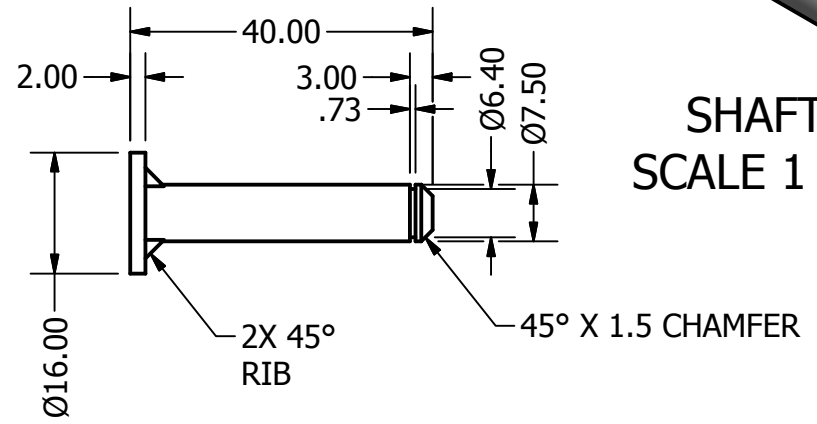

SHAFT  
SCALE 1 : 1

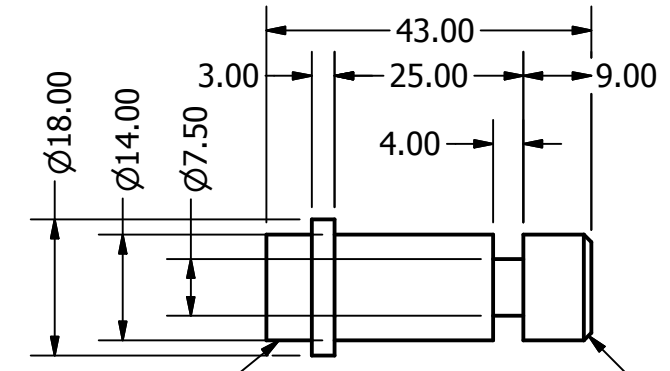

POST  
SCALE 1 : 1

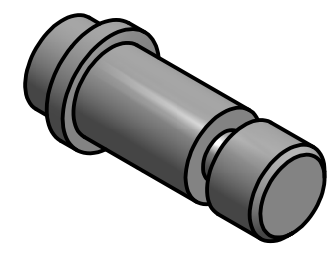

POST  
SCALE 1 : 1

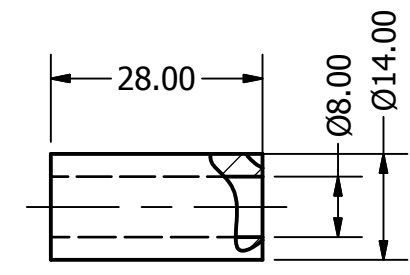

BUSHING  
SCALE 1 : 1

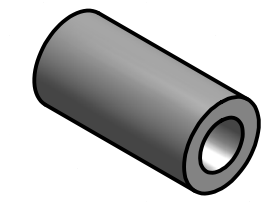

BUSHING  
SCALE 1 : 1

LEGEND:  
°=ANGLE  
Ø=DIAMETER  
R=RADIUS

DIGITAL DESIGN GRAPHICS TECHNOLOGY	NAME	MQUEVEDO	DWG NAME:	14-90 CASTER	SHEET#: 2 OF 2
	COURSE:	DDGT 122	SCALE:	AS NOTED	
	DATE:	5/16/2012			