

PARTS LIST			
ITEM	QTY	PART NUMBER	MATERIAL
1	1	TOP PLATE	MALLEABLE IRON
2	2	AXLE SUPPORT	MALLEABLE IRON
3	2	BUSHING	BRONZE
4	1	AXLE	SAE 1020
5	1	WHEEL	MALLEABLE IRON

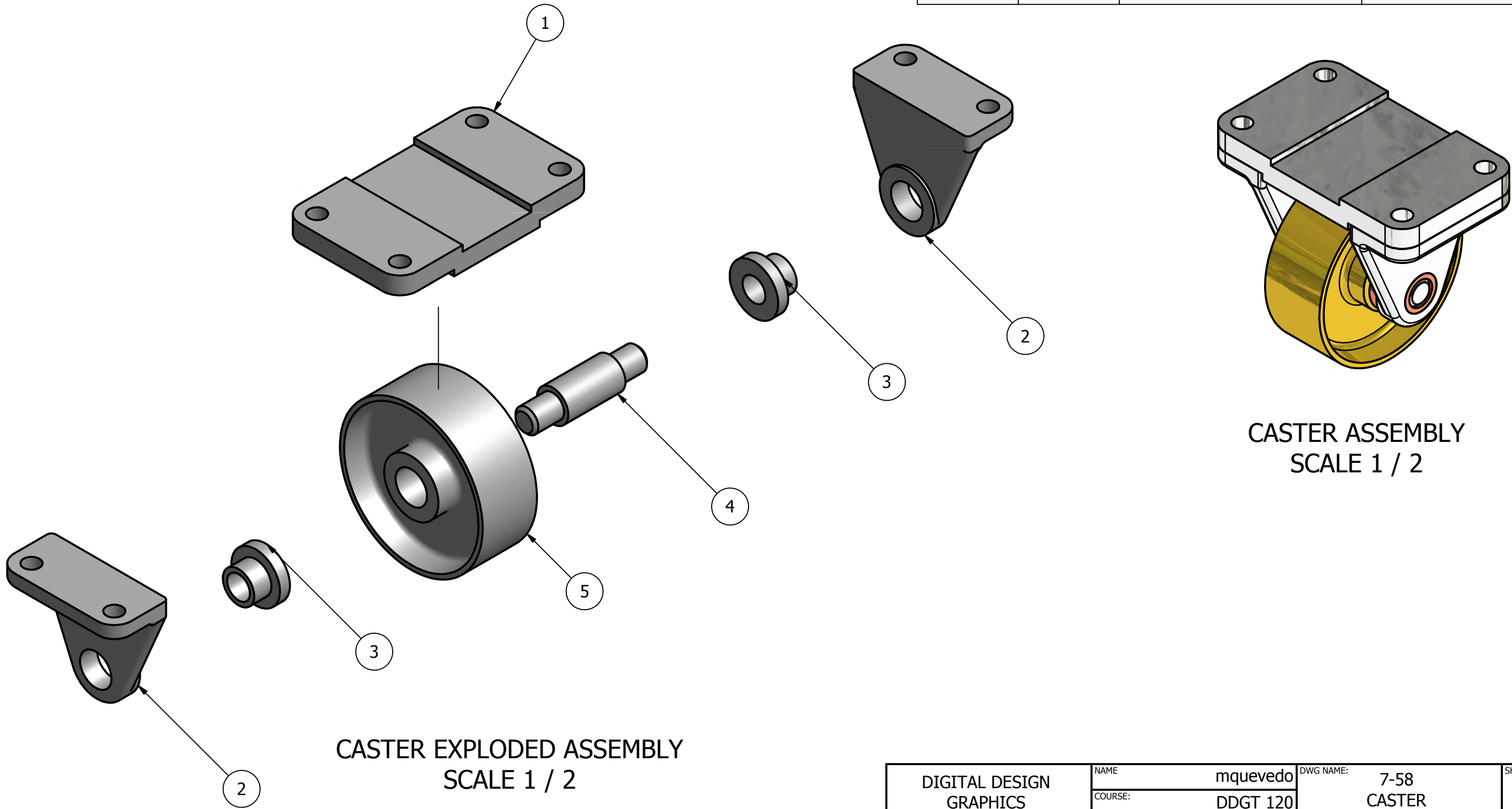

CASTER ASSEMBLY  
SCALE 1 / 2

CASTER EXPLODED ASSEMBLY  
SCALE 1 / 2

DIGITAL DESIGN GRAPHICS TECHNOLOGY	NAME	mquevedo	DWG NAME:	7-58 CASTER	SHEET#:	1 OF 2
	COURSE:	DDGT 120	SCALE:	AS NOTED		
	DATE:	11/3/2011				

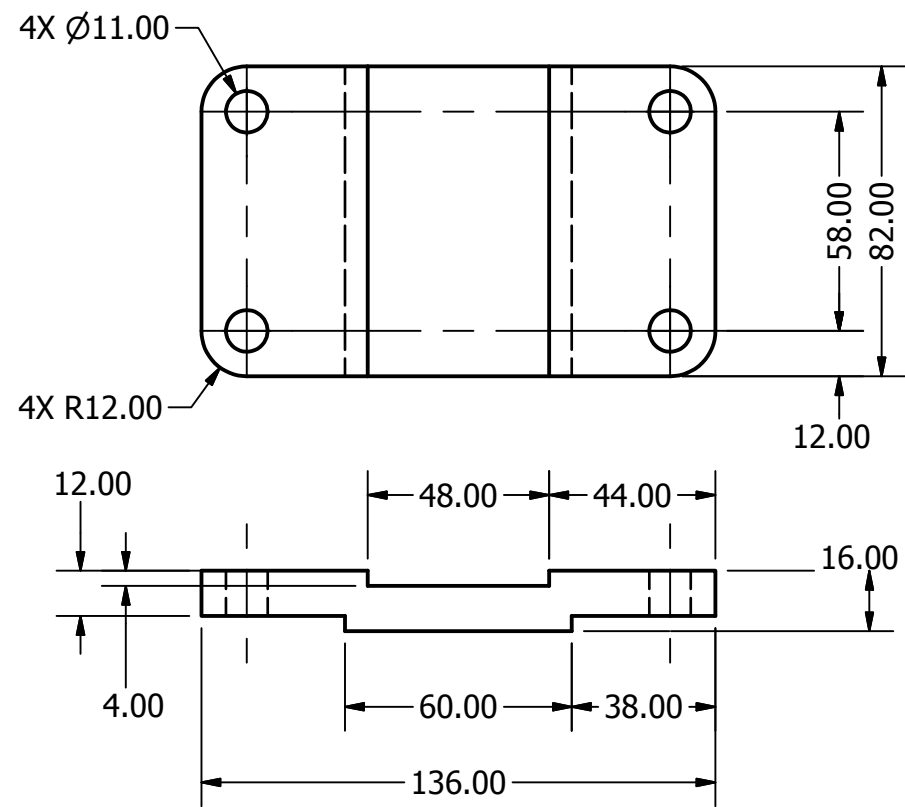

TOP PLATE  
SCALE 1 / 2

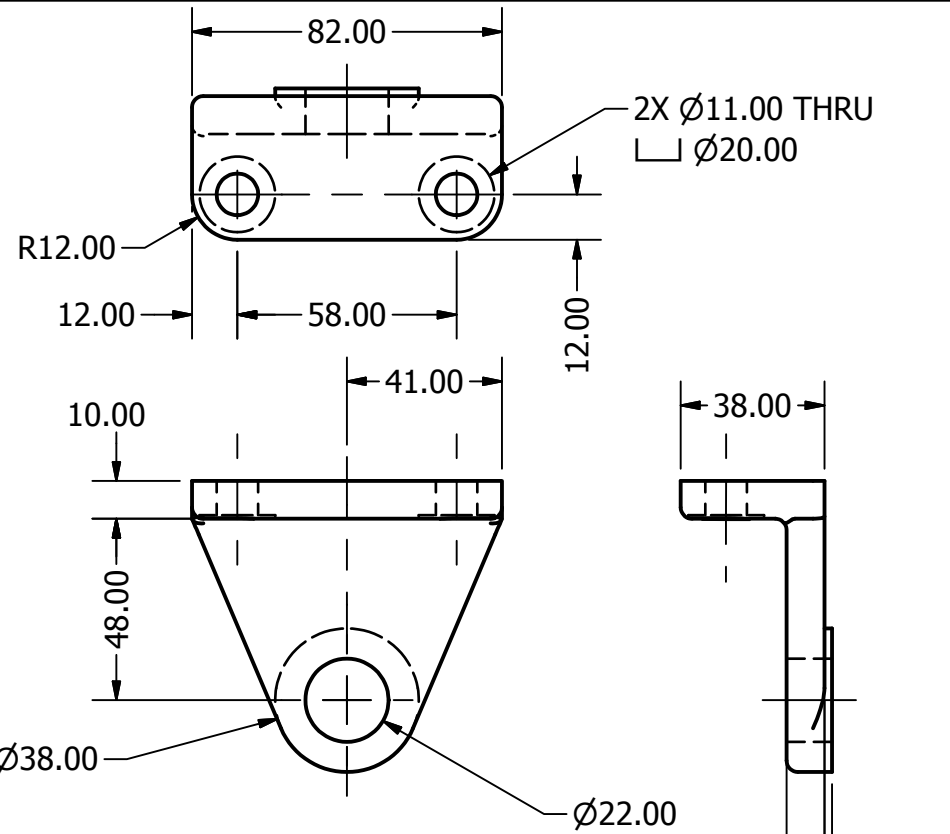

AXLE SUPPORT  
SCALE 1 / 2

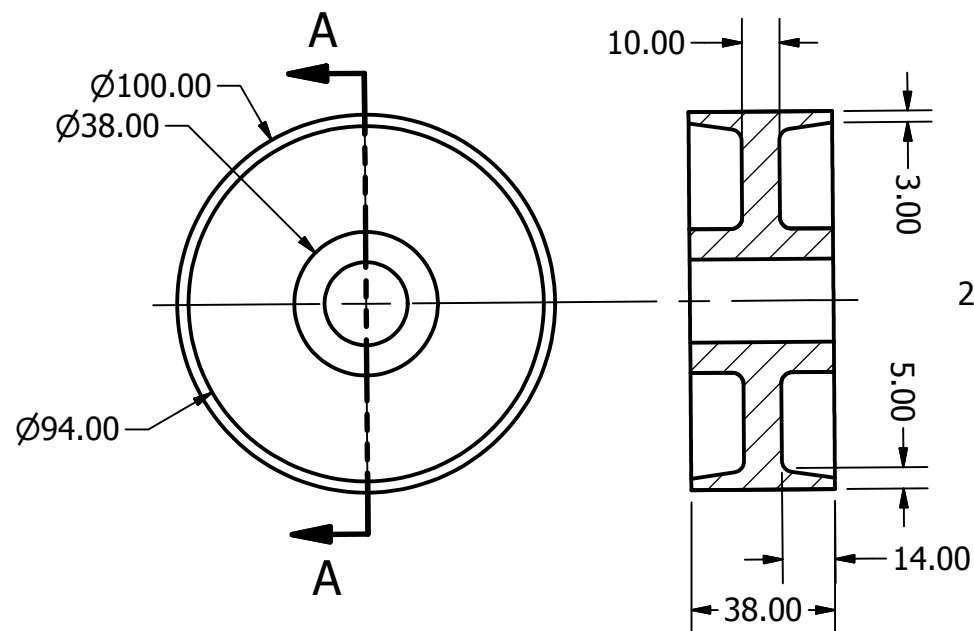

WHEEL  
SCALE 1 / 2

SECTION A-A  
SCALE 1 / 2

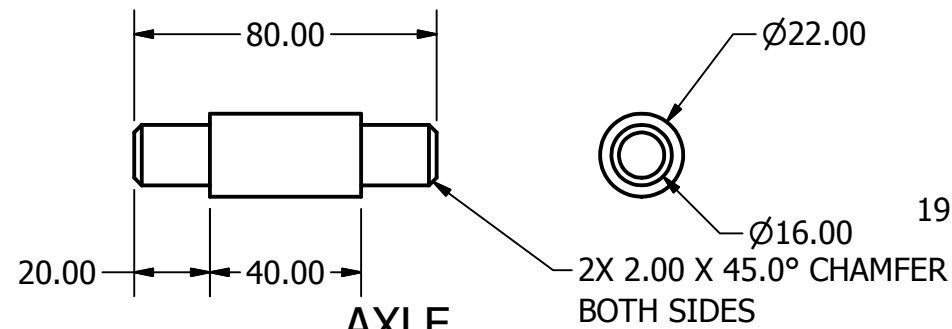

AXLE  
SCALE 1 / 2

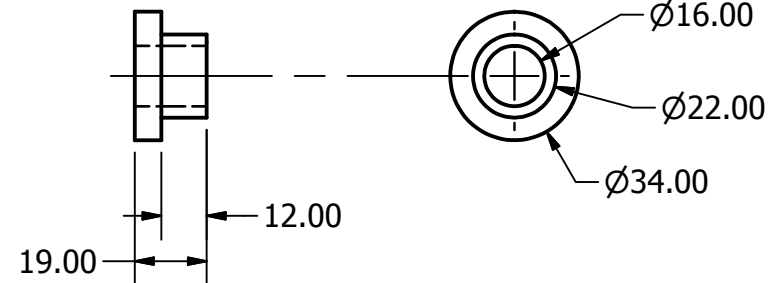

BUSHING  
SCALE 1 / 2

PARTS LIST		
ITEM	QTY	PART NUMBER
1	1	TOP PLATE
2	2	AXLE SUPPORT
3	2	BUSHING
4	1	AXLE
5	1	WHEEL

FIT	BETWEEN PARTS
H8/f7	4 AND 3
H7/p6	2 AND 3
H8/f7	5 AND 4

FASTEN ASSEMBLY TO A 6 mm STEEL PLATE BY FOUR M 10 X 40 mm LG HEX HD BOLTS, NUTS AND LOCK WASHERS. SHOW THE STEEL PLATE IN PHANTOM LINES

ROUNDS AND FILLETS R3

LEGEND:  
°=ANGLE  
Ø=DIAMETER  
R=RADIUS  
□=SPOTFACE

DIGITAL DESIGN GRAPHICS TECHNOLOGY	NAME	mquevedo	DWG NAME:	7-58 CASTER	SHEET#:	2 OF 2
	COURSE:	DDGT 120	SCALE:	AS NOTED		
	DATE:	11/3/2011				