

TROLLEY ASSEMBLY  
SCALE 1 / 2

PARTS LIST				
ITEM	QTY	PART NUMBER	DESCRIPTION	MATERIAL
1	4	AXLE		CRS
2	1	HOOK		
3	12	ADJ. WASHER	26 ID X 44 OD X 4 THICK	STL
4	6	COTTER PIN	6 DIA X 40 LG	DNL
5	2	SIDE PLATE		MST
6	2	GUIDE		CI
7	4	RIVET	BUTTON HEAD, 10 DIA X 60 LG	DNL
8	4	LOCKNUT	M16 X 2 PREVAILING TORQUE INSERT TYPE	DNL
9	4	WHEEL		CI
10	4	WASHER	26 ID X 65 OD X 3 THICK	DNL
11	44	ROLLER BEARING		CRS
12	1	WHEEL AXLE		CRS
13	4	WHEEL SUBASSEMBLY	SUBASSEMBLY	N/A
14	2	SIDEPLATE SUBASSEMBLY	SUBLASEMBLY	N/A

TROLLEY SHOULD BE MONTED ON AN S200 X 34 BEAM

DIGITAL DESIGN GRAPHICS TECHNOLOGY	NAME	M.QUEVEDO	DWG NAME:	14-83 TROLLEY	SHEET#:	1 OF 6
	COURSE:	DDGT 120	SCALE:	AS NOTED		
	DATE:	11/30/2011				

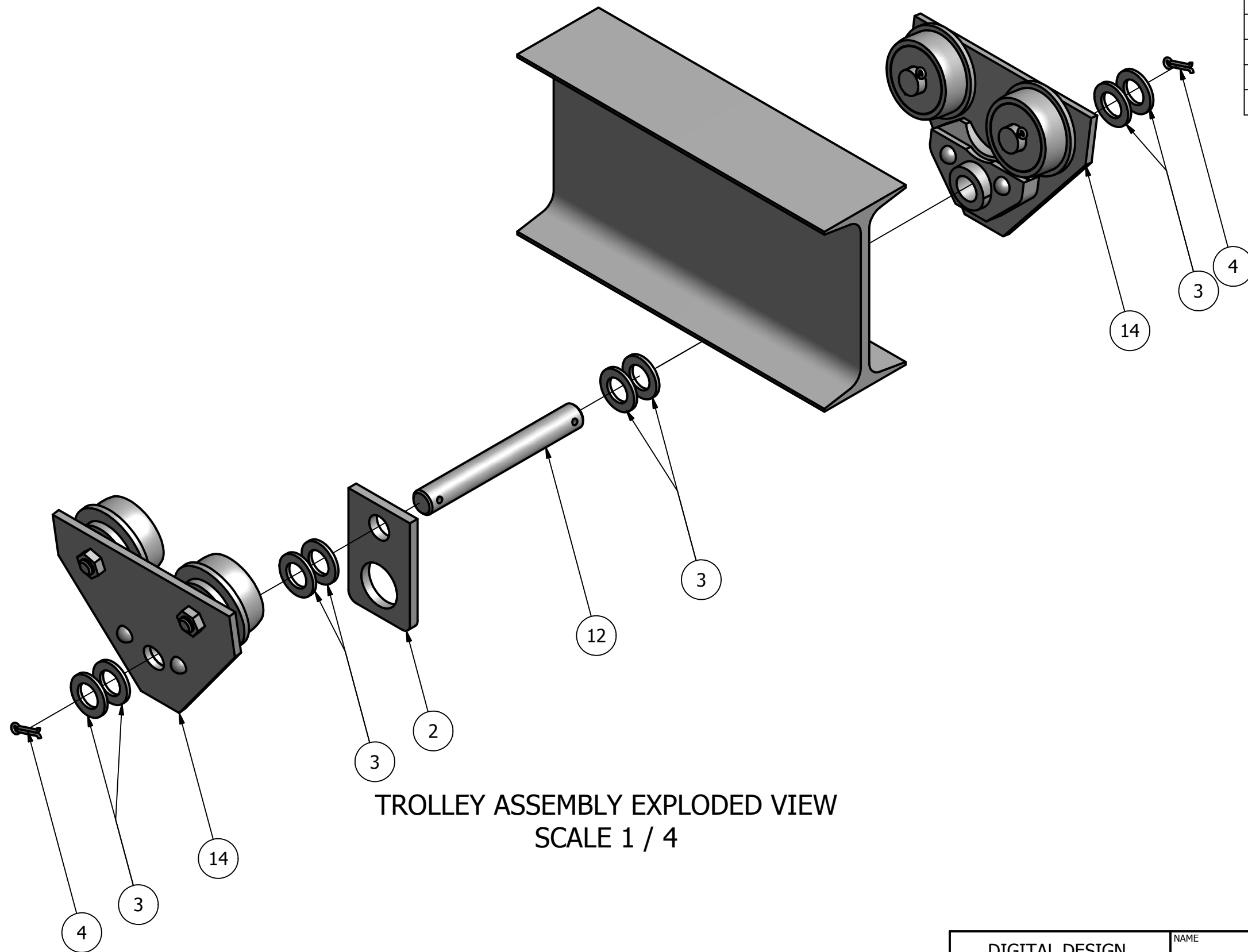

PARTS LIST		
ITEM	QTY	PART NUMBER
2	1	HOOK
3	12	ADJ. WASHER
4	6	COTTER PIN
12	1	WHEEL AXLE
14	2	SIDEPLATE SUBASSEMBLY

TROLLEY ASSEMBLY EXPLODED VIEW  
SCALE 1 / 4

DIGITAL DESIGN GRAPHICS TECHNOLOGY	NAME	M.QUEVEDO	DWG NAME:	14-83	SHEET#:  2 OF 6
	COURSE:	DDGT 120		TROLLEY	
	DATE:	11/30/2011	SCALE:	AS NOTED	

PARTS LIST		
ITEM	QTY	PART NUMBER
5	2	SIDE PLATE
6	2	GUIDE
7	4	RIVET
8	4	LOCKNUT
13	4	WHEEL SUBASSEMBLY

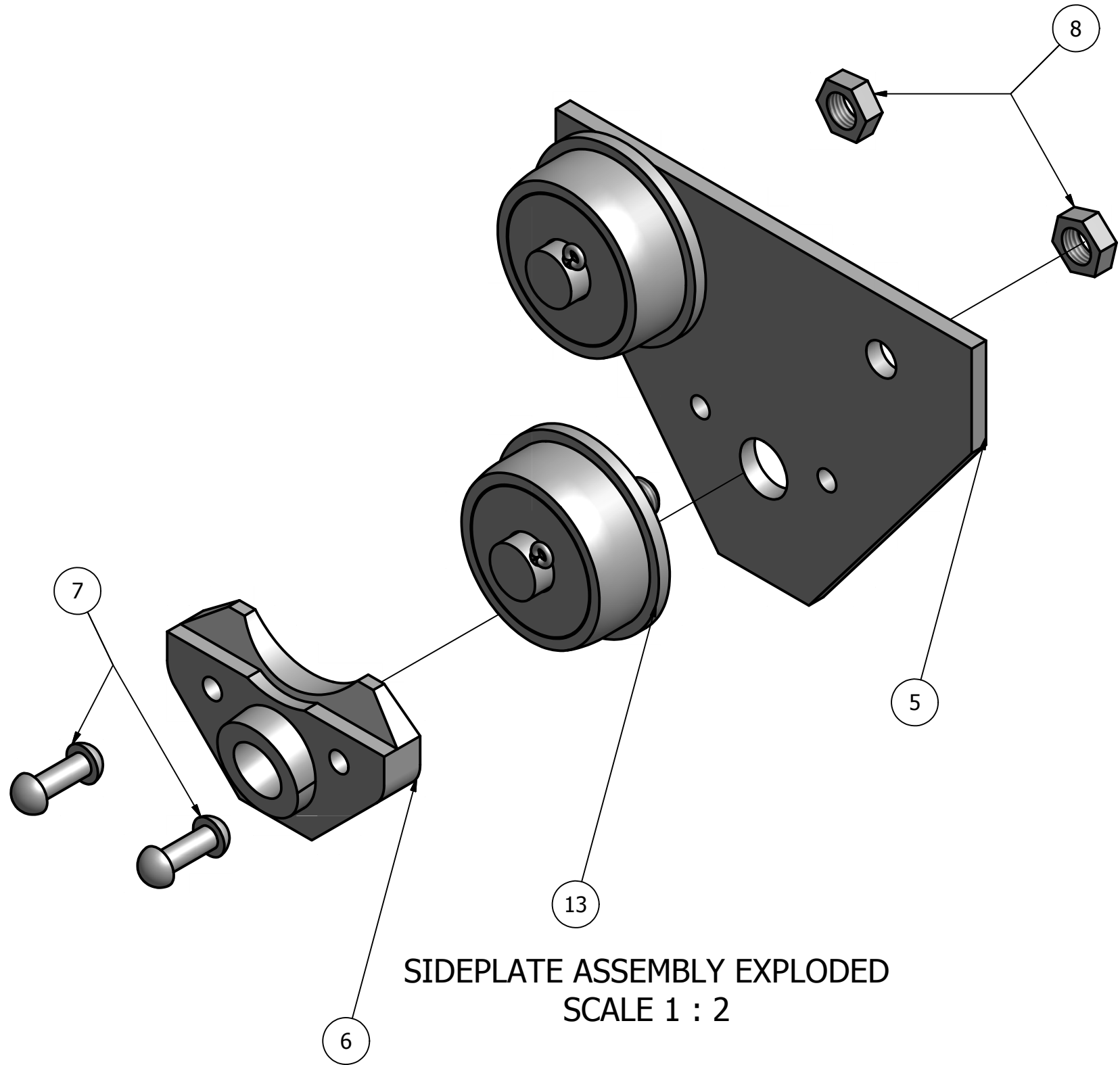

SIDEPLATE ASSEMBLY EXPLODED  
SCALE 1 : 2

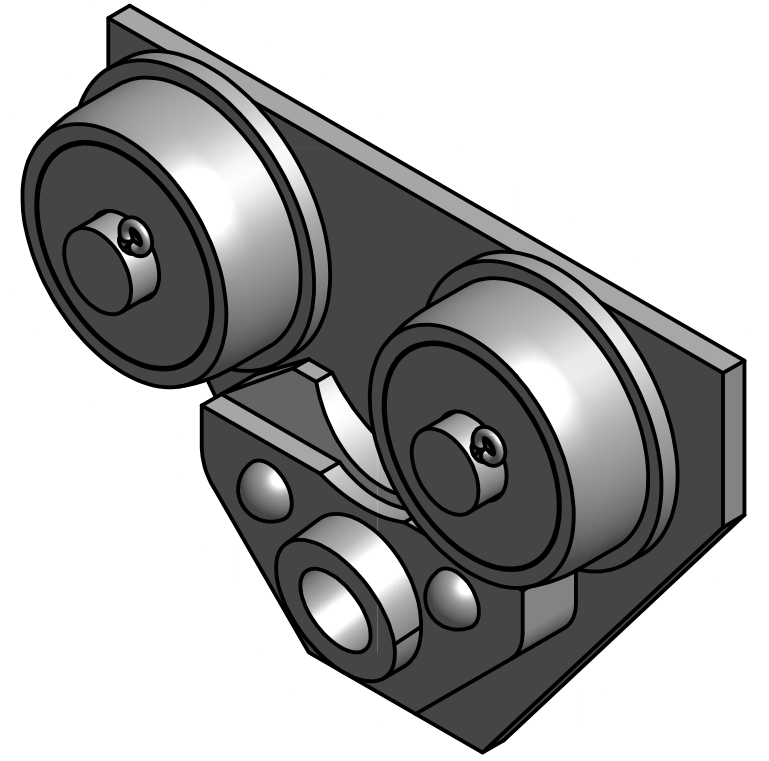

SIDEPLATE SUBASSEMBLY  
SCALE 1 : 2

DIGITAL DESIGN GRAPHICS TECHNOLOGY	NAME	M.QUEVEDO	DWG NAME:	14-83	SHEET#: 3 OF 6
	COURSE:	DDGT 120		TROLLEY	
	DATE:	11/30/2011	SCALE:	AS NOTED	

PARTS LIST		
ITEM	QTY	PART NUMBER
1	4	AXLE
3	12	ADJ. WASHER
4	6	COTTER PIN
9	4	WHEEL
10	4	WASHER
11	44	ROLLER BEARING

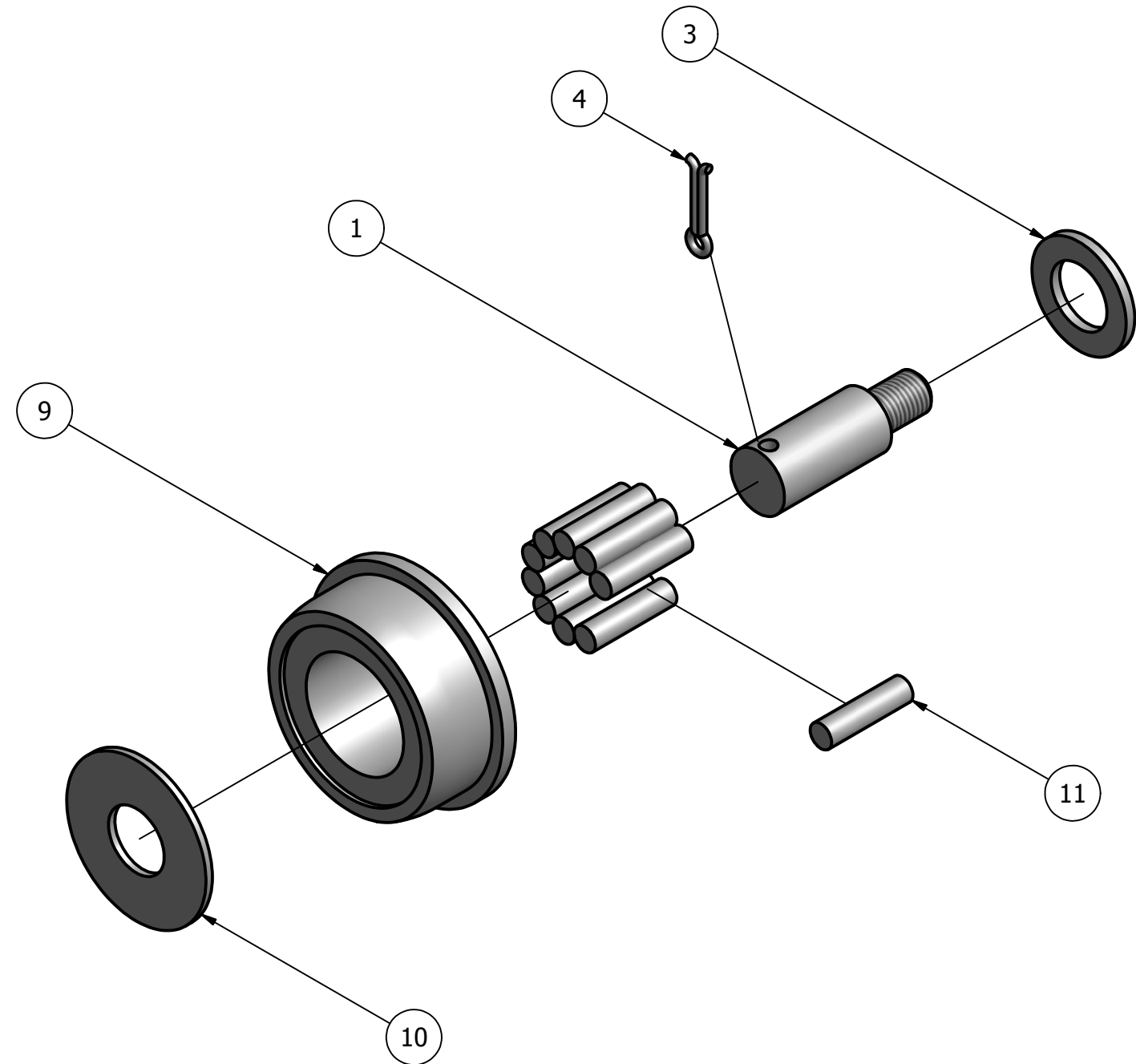

WHEEL ASSEMBLY EXPLODED  
SCALE 1 : 2

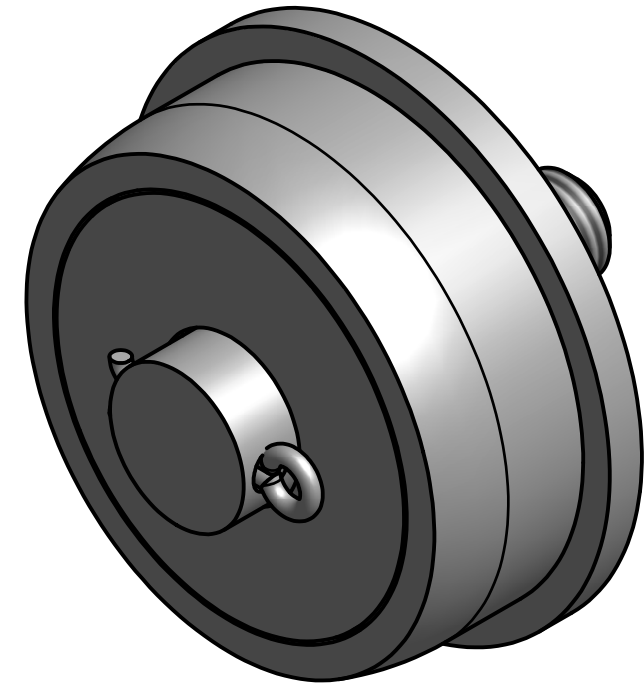

WHEEL ASSEMBLY  
SCALE 1:1

DIGITAL DESIGN GRAPHICS TECHNOLOGY	NAME	M.QUEVEDO	DWG NAME:	14-83	SHEET#: 4 OF 6
	COURSE:	DDGT 120		TROLLEY	
	DATE:	11/30/2011	SCALE:	AS NOTED	

PART LIST		
ITEM	QTY	PART NUMBER
5	4	SIDEPLATE
6	2	GUIDE
12	1	WHEEL AXLE

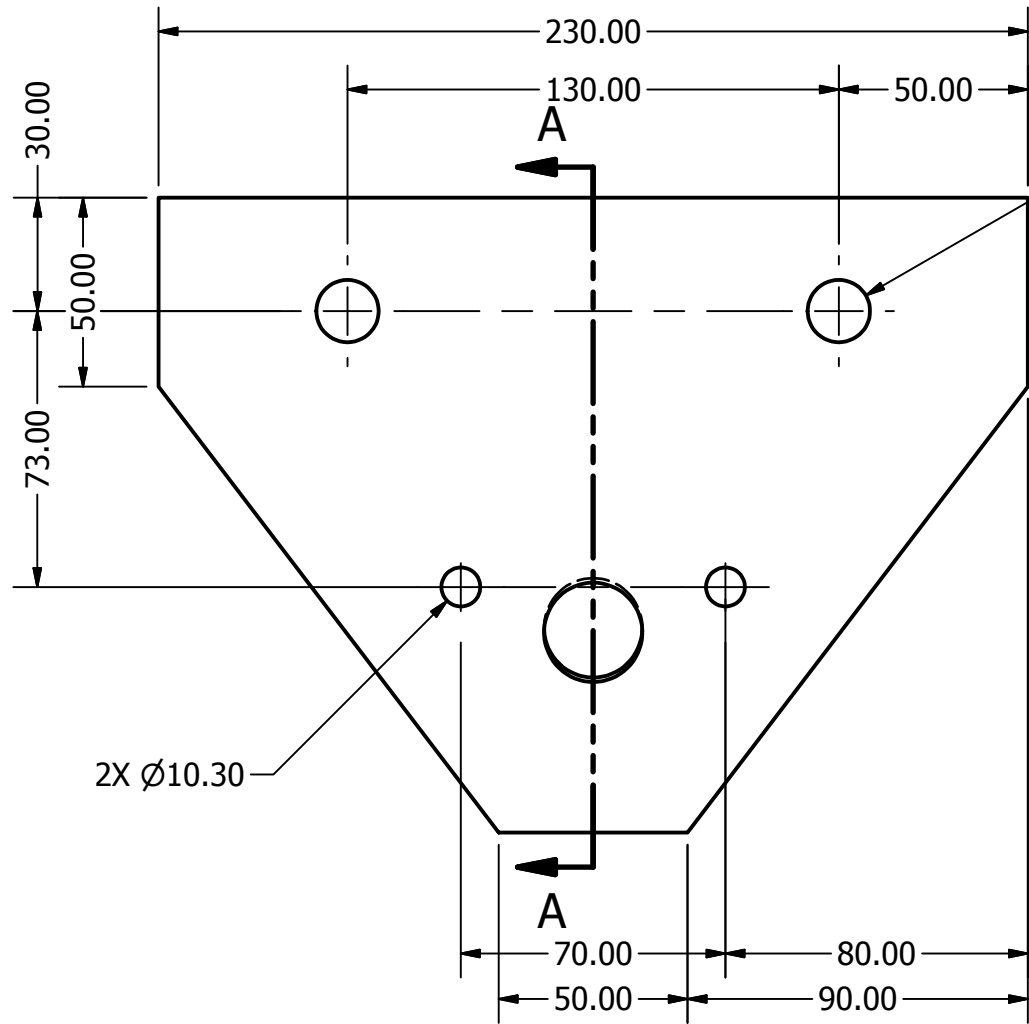

SIDE PLATE  
SCALE 1/2

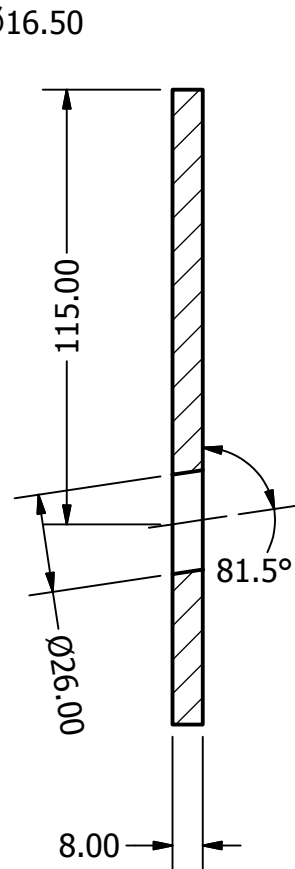

SECTION A-A  
SCALE 1/2

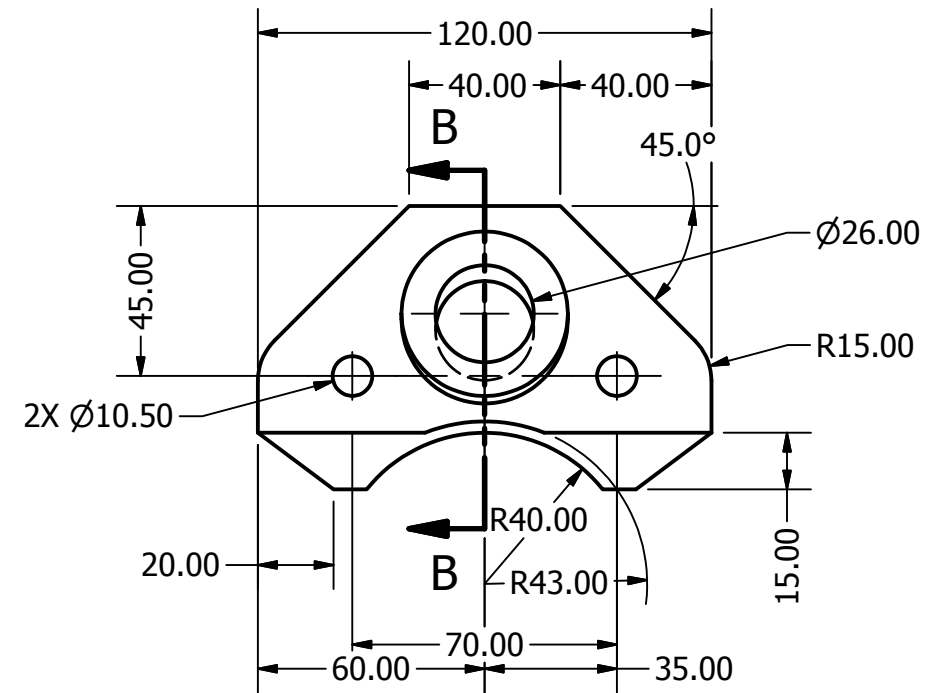

GUIDE  
SCALE 1/2

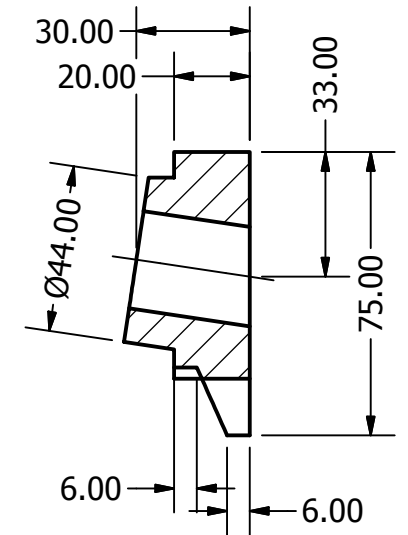

SECTION B-B  
SCALE 1/2

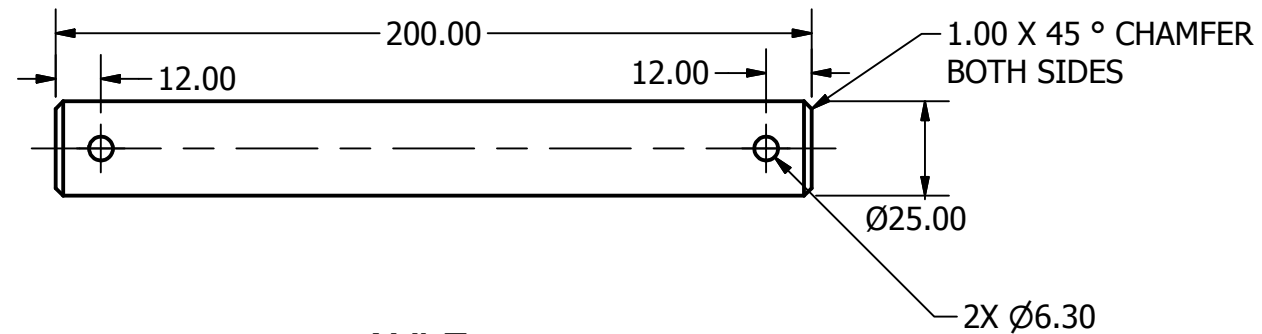

AXLE  
SCALE 1/2

LEGEND  
°=ANGLE  
Ø=DIAMETER  
R=RADIUS

DIGITAL DESIGN GRAPHICS TECHNOLOGY	NAME	M.QUEVEDO	DWG NAME:	14-83 TROLLEY	SHEET#:	5 OF 6
	COURSE:	DDGT 120	SCALE:	AS NOTED		
	DATE:	11/30/2011				

PART LIST		
ITEM	QTY	PART NUMBER
1	4	AXLE
2	1	HOOK
9	4	WHEEL
11	44	ROLLER BEARING

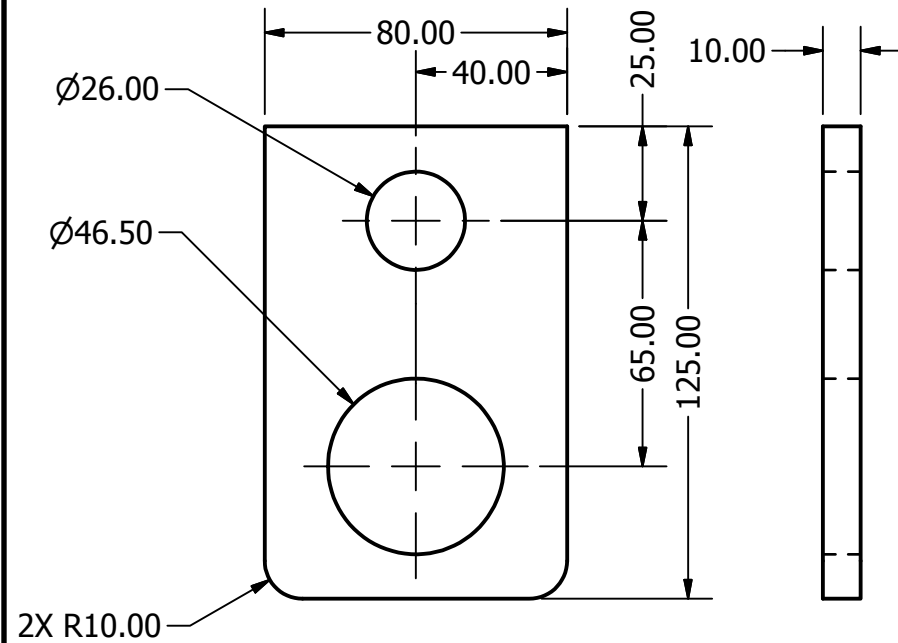

HOOK  
SCALE 1/2

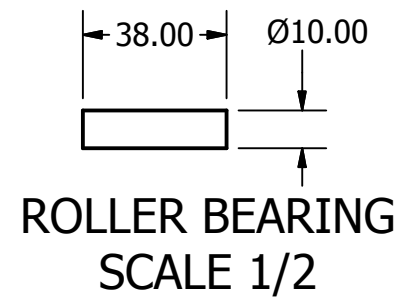

ROLLER BEARING  
SCALE 1/2

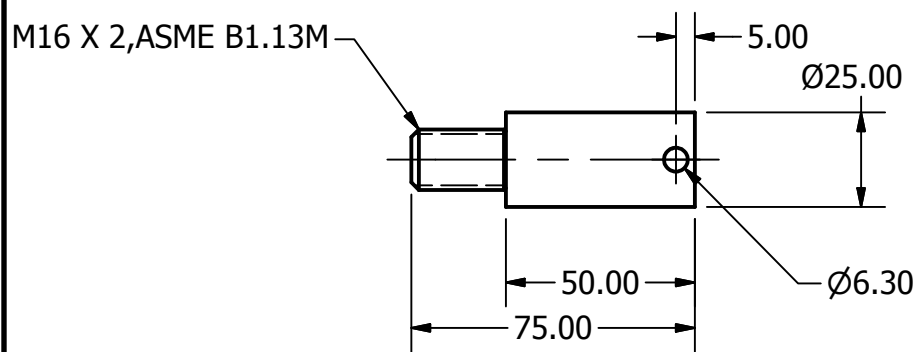

AXLE  
SCALE 1/2

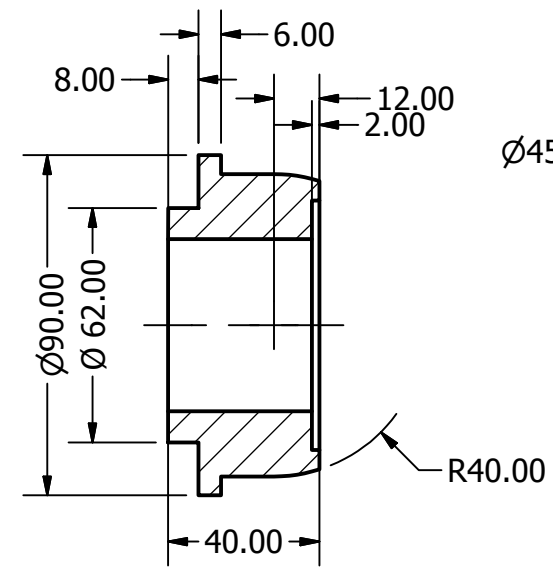

SECTION C-C  
SCALE 1/2

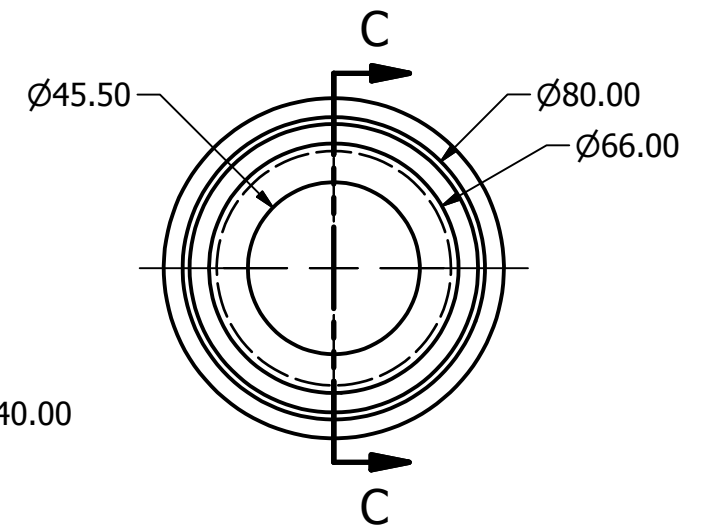

WHEEL  
SCALE 1/2

DIGITAL DESIGN GRAPHICS TECHNOLOGY	NAME: M.QUEVEDO	DWG NAME: 14-83	SHEET#: 6 OF 6
	COURSE: DDGT 120	TROLLEY	
	DATE: 11/30/2011	SCALE: AS NOTED	