

PARTS LIST			
ITEM	QTY	PART NUMBER	MATERIAL
1	1	DRILL PRESS BRACKET	MALLEABLE IRON



DIGITAL DESIGN  
GRAPHICS  
TECHNOLOGY

WWW.DDGT.NET

GENERAL NOTES:  
ALL ROUNDS AND  
FILLETS R. 1/8 UNLESS  
OTHERWISE SPECIFIED

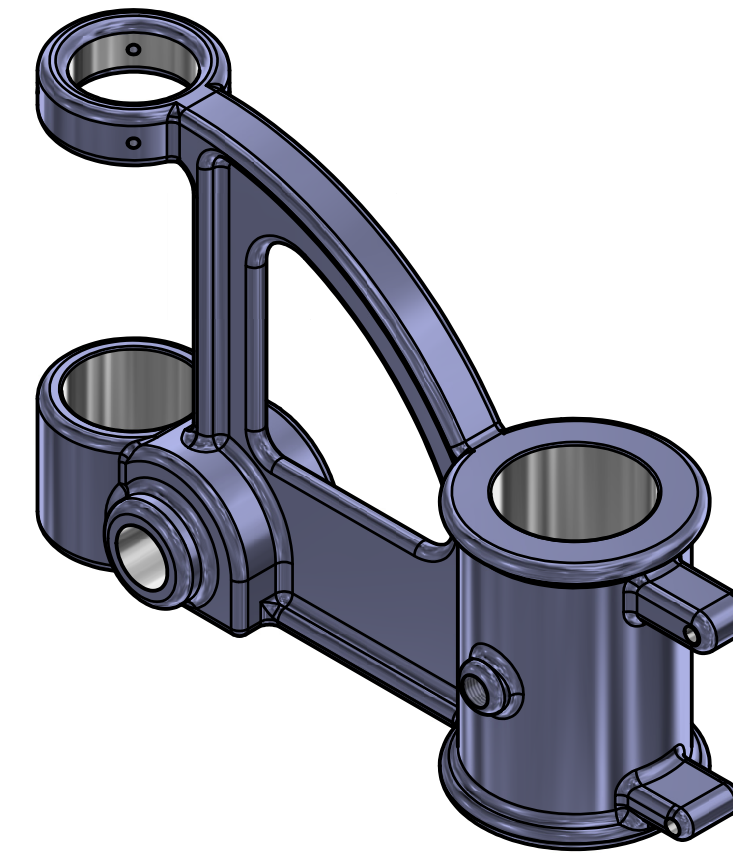
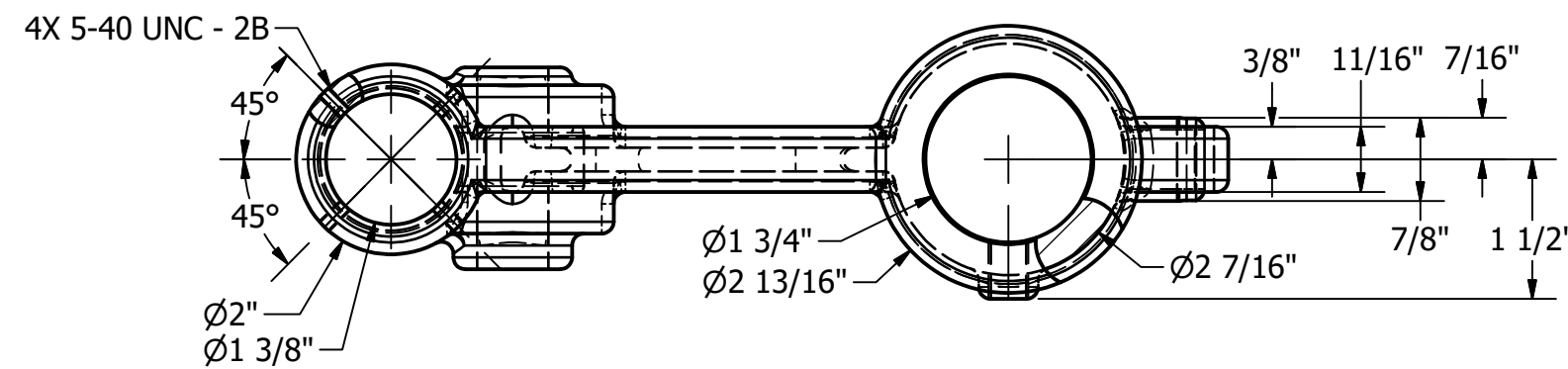
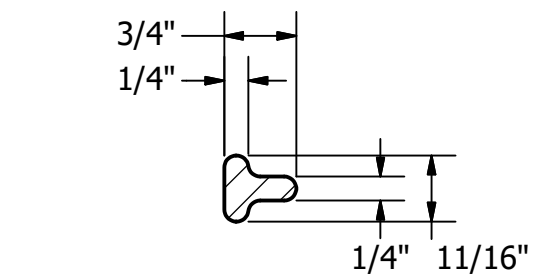
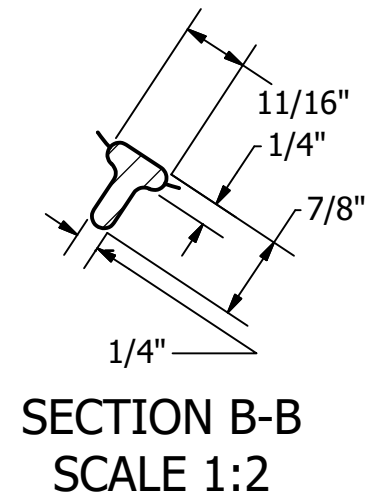

ISOMETRIC  
SCALE 1:2

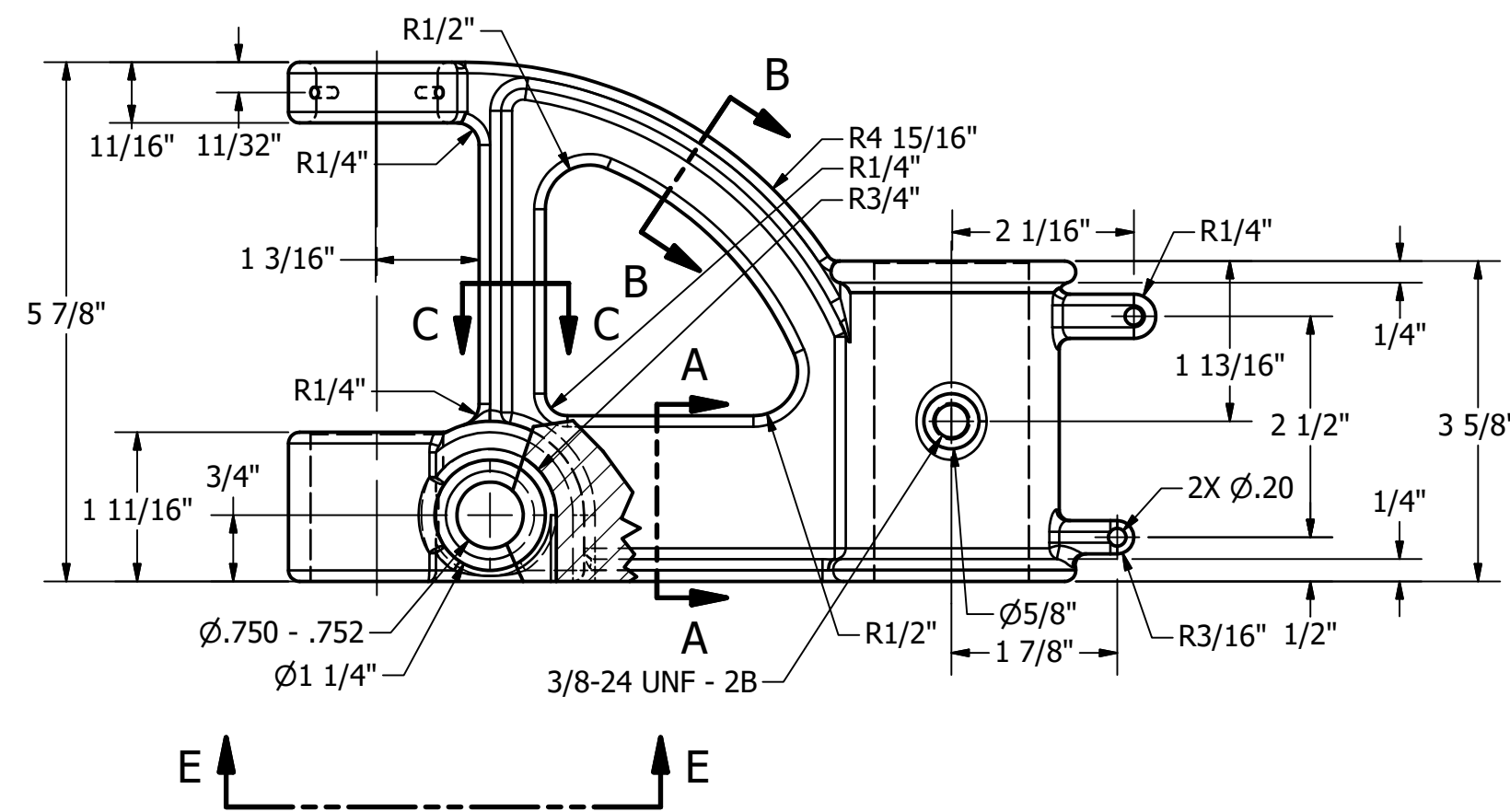
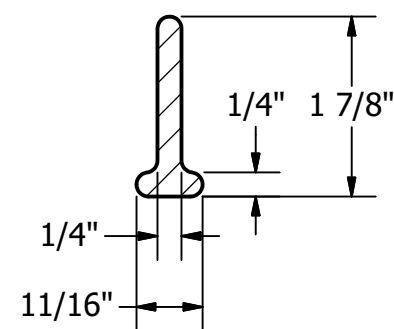

DRILL PRESS BRACKET  
SCALE 1:2

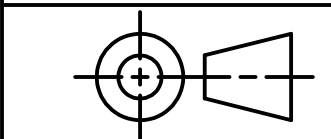
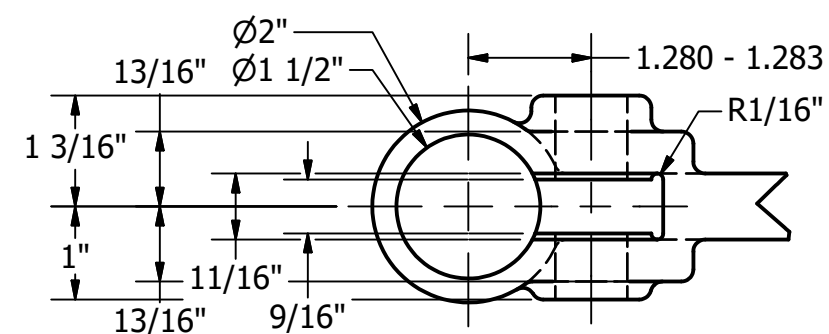

TOLERANCES UNLESS SPECIFIED:  
DECIMAL INCHES  
X = ±.020  
XX = ±.010  
XXX = ±.005  
FRACTIONAL ±1/64"  
ANGLES ±1 DEGREE  
SURFACES  $\sqrt{\quad}$

COURSE: DDGT121

INVENTOR DRAWING NAME:  
DRILL PRESS BRACKET

FIG #: 14-35

DRAFTER: N. SCHAFFER

DATE: 4/10/2018

SCALE: AS NOTED

PAGE #: 1 OF 1

**LEGEND:**  
Ø DIAMETER  
R RADIUS  
° DEGREES