

MASTER EXPLODED ASSEMBLY
SCALE 1:2

GENERAL NOTES
 FILLETS AND ROUNDS R .06 UNLESS OTHERWISE NOTED
 CHAMFERS .02 X 45° UNLESS OTHERWISE NOTED

PARTS LIST				
ITEM	QTY	PART NUMBER	MATERIAL	DESCRIPTION
1	1	BASE E-01	ALUMINUM	PAINT
2	1	ARM E-01	ALUMINUM	PAINT
3	2	VACUUM CAP	ALUMINUM	
4	1	ELBOW CAP	ALUMINUM	
5	1	SLIDING TUBE	STEEL	
6	1	VACUUM CONNECTOR	STEEL	
7	1	VACUUM CUP	RUBBER	
8	3	CAP SCREW	STEEL	
9	1	ARM E-02	ALUMINUM	PAINT
10	1	BASE CAP	ALUMINUM	
11	1	AIR HOSE	RUBBER	.125" OD, .0625 ID, 12" LONG

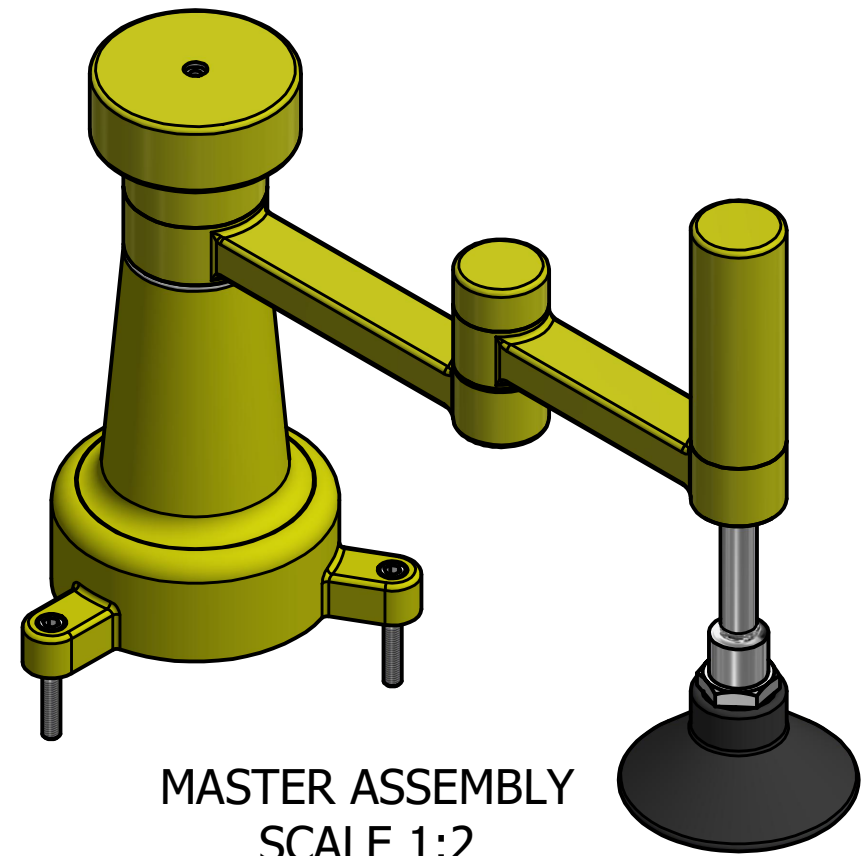

MASTER ASSEMBLY
SCALE 1:2

LEGEND:
 ° DEGREES
 Ø DIAMETER
 R RADIUS
 □ SPOTFACE
 ▽ DEPTH

DDGT
 DIGITAL DESIGN
 GRAPHICS
 TECHNOLOGY
 WWW.DDGT.NET

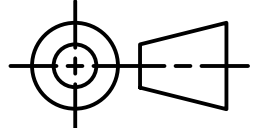

 Sébastien Bolle
 sebastien.a.bolle@gmail.com
 www.ddgt.net/StudentPages/sbolle

 TOLERANCES UNLESS SPECIFIED:
 DECIMAL INCHES:
 X = ±.020
 XX = ±.010
 XXX = ±.005
 FRACTIONAL ±1/64"
 ANGLES ±1 DEGREE
 SURFACES 32 ✓

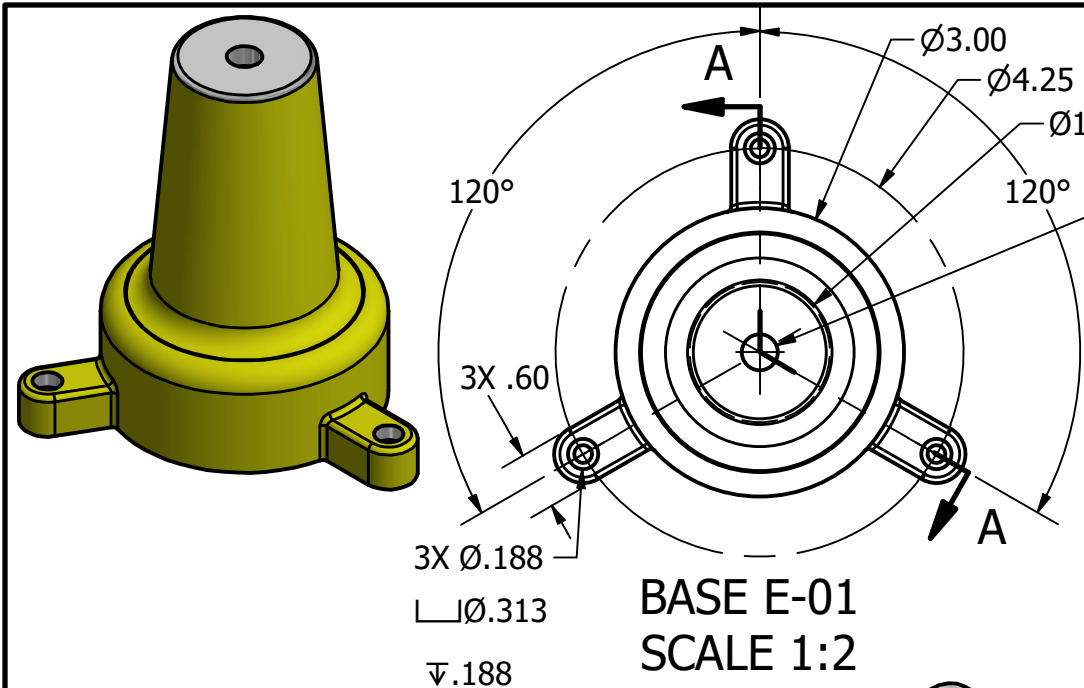
COURSE:	DDGT240
INVENTOR DRAWING NAME:	SCARA ASSEMBLY
FIG#:	1058
DRAFTER:	S. BOLLE
DATE:	2/14/2018
SCALE:	AS NOTED
PAGE #:	1 OF 3

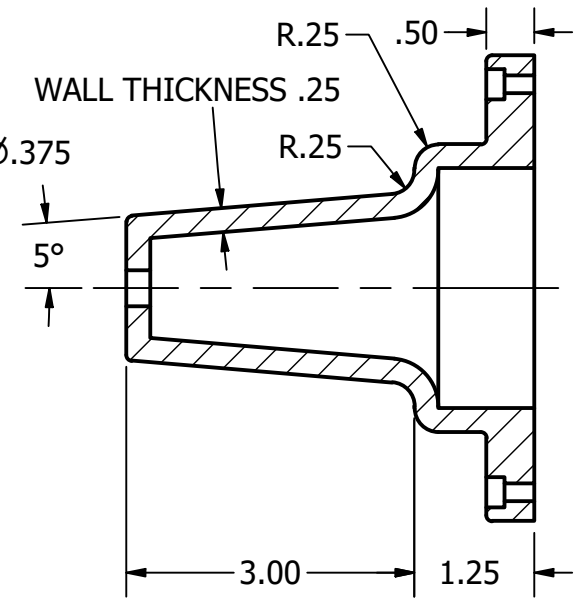

BASE E-01
SCALE 1:2



SECTION A-A
SCALE 1:2

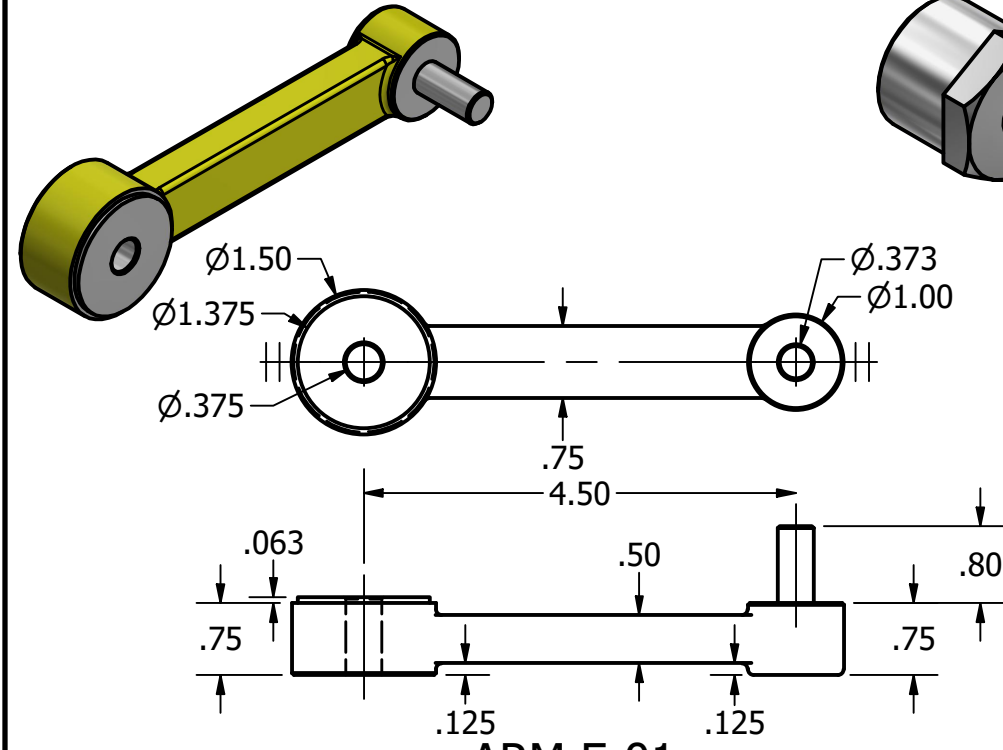

ARM E-01
SCALE 1:2

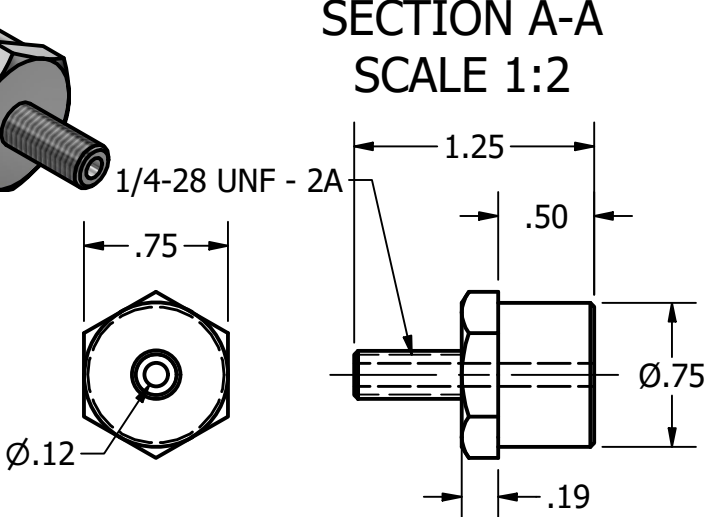

VACUUM CONNECTOR
SCALE 1:1

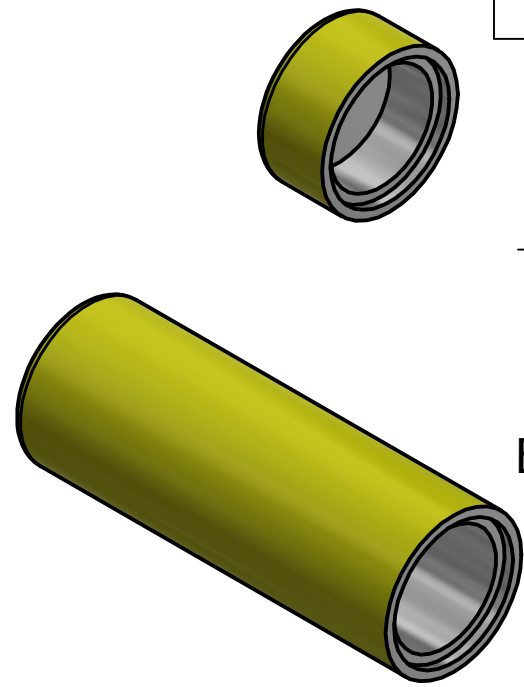

B
ELBOW CAP
SCALE 1:1

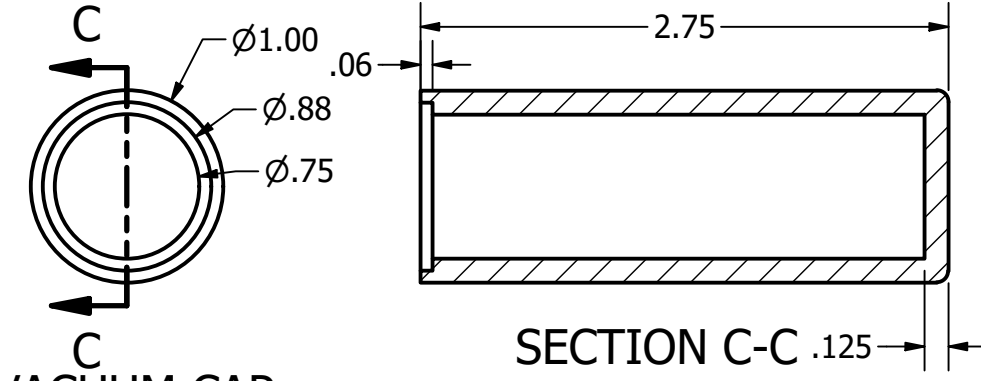

C
VACUUM CAP
SCALE 1:1

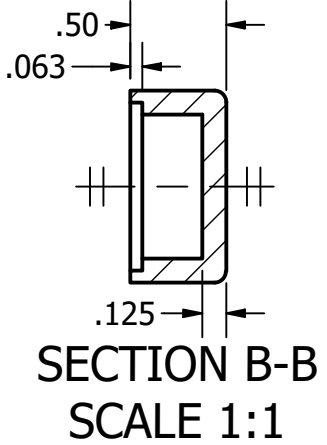

SECTION B-B
SCALE 1:1

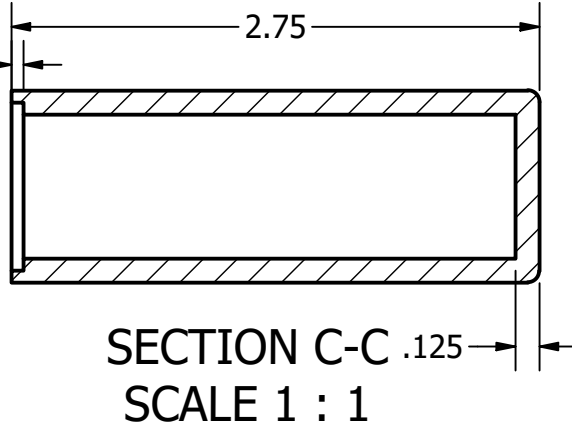

SECTION C-C
SCALE 1:1

PARTS LIST		
ITEM	QTY	PART NUMBER
1	1	BASE E-01
2	1	ARM E-01
3	2	VACUUM CAP
4	1	ELBOW CAP
6	1	VACUUM CONNECTOR
11	1	AIR HOSE

LEGEND:

- ° DEGREES
- Ø DIAMETER
- R RADIUS
- ┌ SPOTFACE
- ▽ DEPTH

GENERAL NOTES
 FILLETS AND ROUNDS R .06 UNLESS OTHERWISE NOTED
 CHAMFERS .02 X 45° UNLESS OTHERWISE NOTED

DDGT
 DIGITAL DESIGN
 GRAPHICS
 TECHNOLOGY
 WWW.DDGT.NET

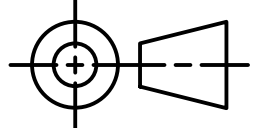

 Sebastien Bolle
 sebastien.a.bolle@gmail.com
 www.ddgt.net/StudentPages/sbolle

 TOLERANCES UNLESS SPECIFIED:
 DECIMAL INCHES:
 X = ±.020
 XX = ±.010
 XXX = ±.005
 FRACTIONAL ±1/64"
 ANGLES ±1 DEGREE
 SURFACES 32 ✓

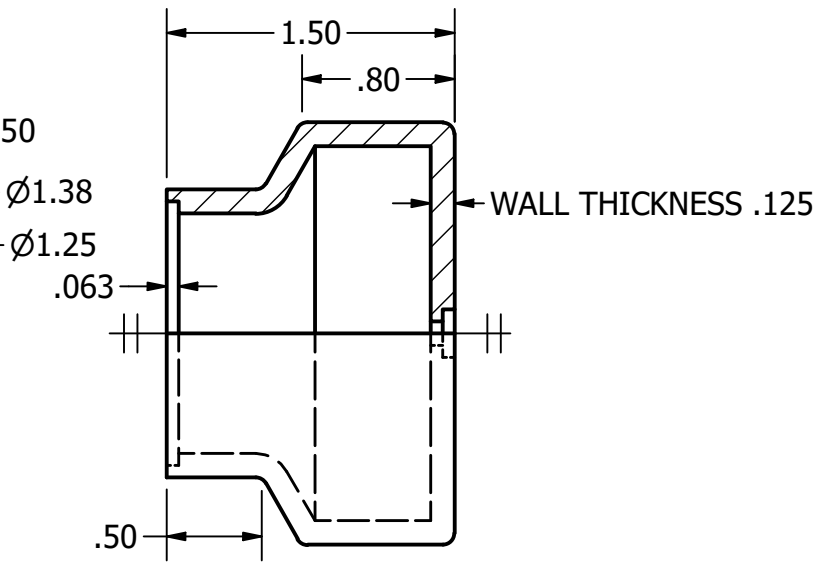
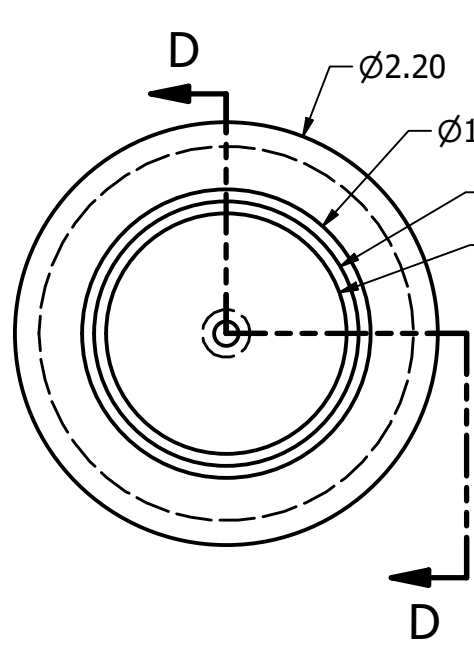
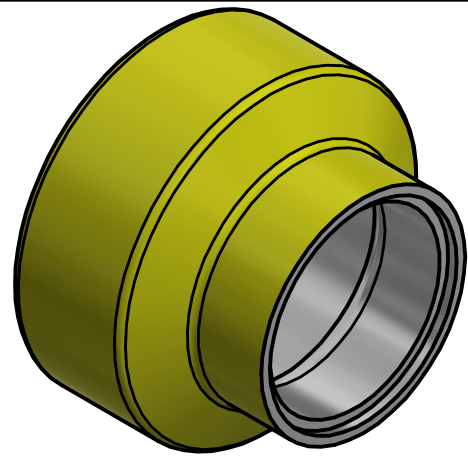
COURSE:	DDGT240
INVENTOR DRAWING NAME:	SCARA ASSEMBLY
FIG#:	1058
DRAFTER:	S. BOLLE
DATE:	2/14/2018
SCALE:	AS NOTED
PAGE #:	2 OF 3

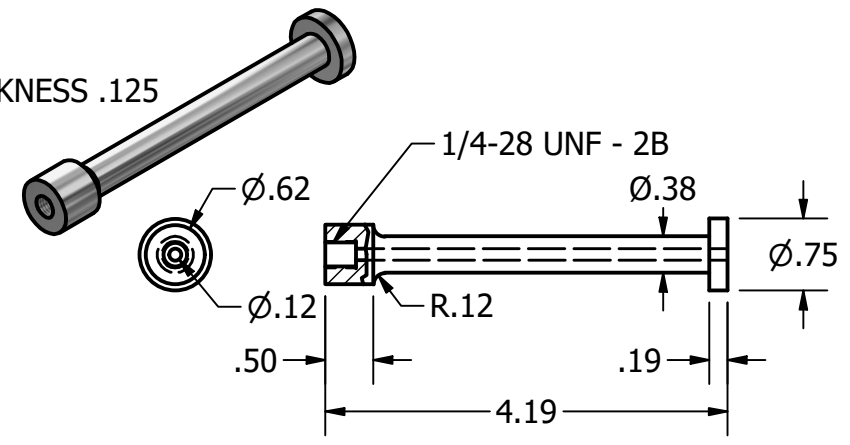

SECTION D-D
SCALE 1 : 1



SECTION E-E
SCALE 1 / 2

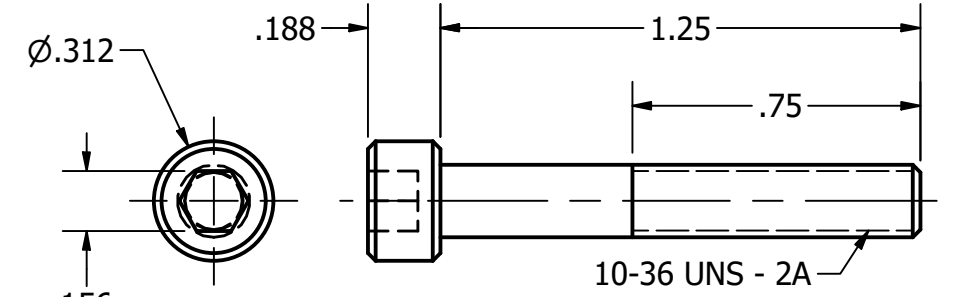
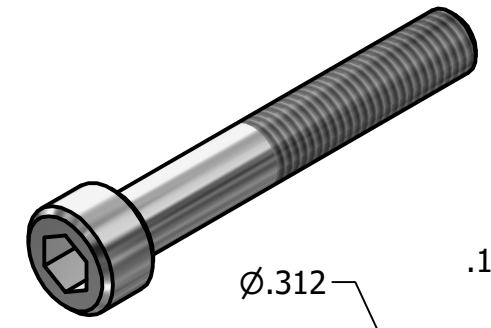

CAP SCREW
SCALE 2:1

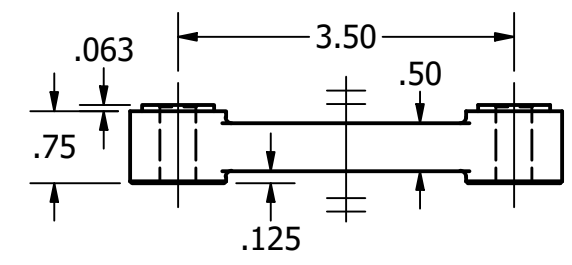
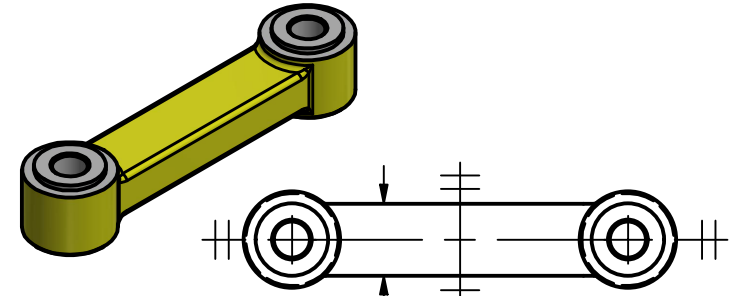

PARTS LIST		
ITEM	QTY	PART NUMBER
3	2	VACUUM CAP
4	1	ELBOW CAP
7	1	VACUUM CUP
9	1	ARM E-02
10	1	BASE CAP
11	1	AIR HOSE

LEGEND:

- ° DEGREES
- Ø DIAMETER
- R RADIUS
- SPOTFACE
- ∇ DEPTH

GENERAL NOTES

FILLETS AND ROUNDS R .06 UNLESS OTHERWISE NOTED
 CHAMFERS .02 X 45° UNLESS OTHERWISE NOTED

DDGT
 DIGITAL DESIGN
 GRAPHICS
 TECHNOLOGY
 WWW.DDGT.NET

 Sebastien Bolle
 sebastien.a.bolle@gmail.com
 www.ddgt.net/StudentPages/sbolle

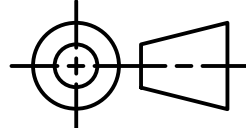
 TOLERANCES UNLESS SPECIFIED:
 DECIMAL INCHES:
 X = ±.020
 XX = ±.010
 XXX = ±.005
 FRACTIONAL ±1/64"
 ANGLES ±1 DEGREE
 SURFACES 32 ✓

COURSE:	DDGT240
INVENTOR DRAWING NAME:	SCARA ASSEMBLY
FIG#:	1058
DRAFTER:	S. BOLLE
DATE:	2/14/2018
SCALE:	AS NOTED
PAGE #:	3 OF 3