

PARTS LIST			
ITEM	QTY	PART NUMBER	MATERIAL
1	1	DRILL PRESS BRACKET	CAST IRON

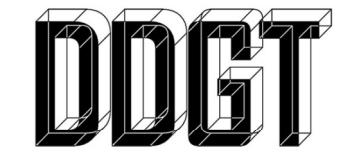

DIGITAL DESIGN  
GRAPHICS  
TECHNOLOGY

WWW.DDGT.NET

GENERAL NOTES:  
ALL FILLETS & ROUNDS  
ARE R=1/8" UNLESS  
OTHERWISE SPECIFIED

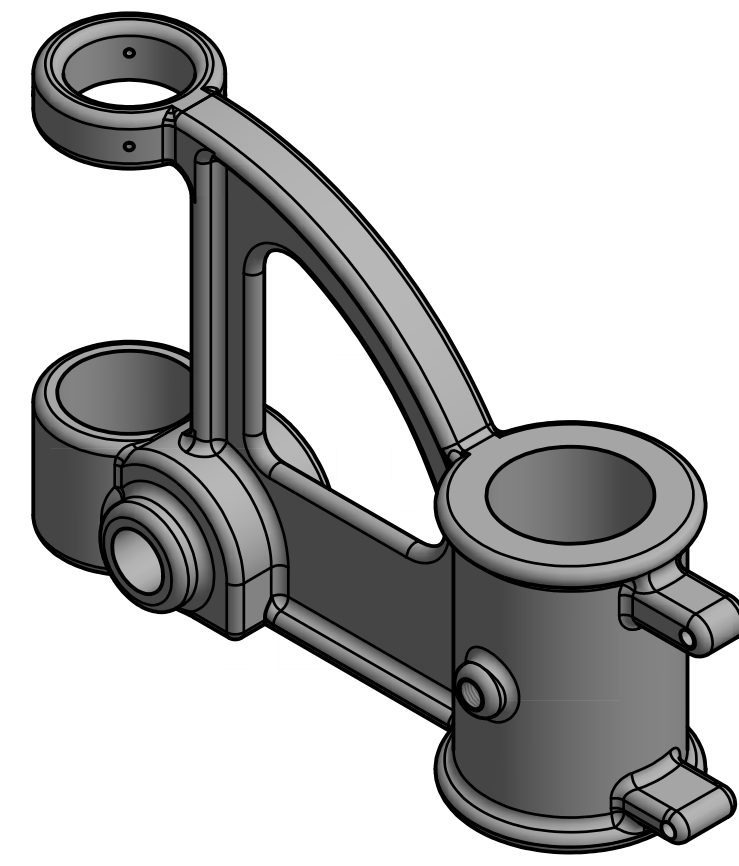

DRILL PRESS BRACKET  
SCALE 1 / 2

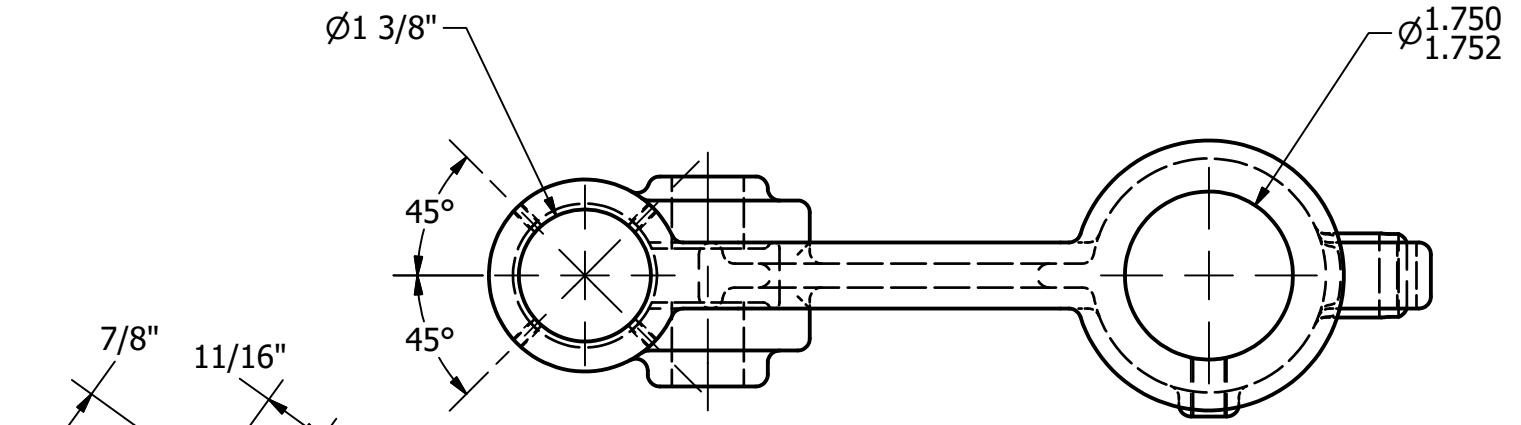

TOP VIEW  
SCALE 1 / 2

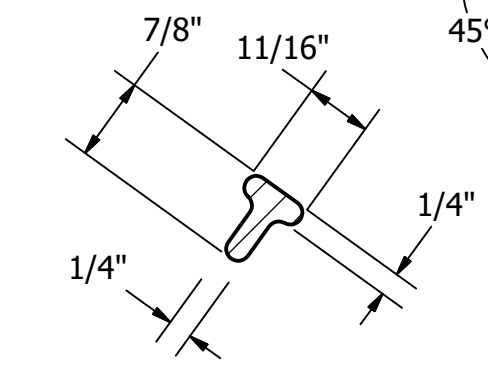

SECTION A-A  
SCALE 1 / 2

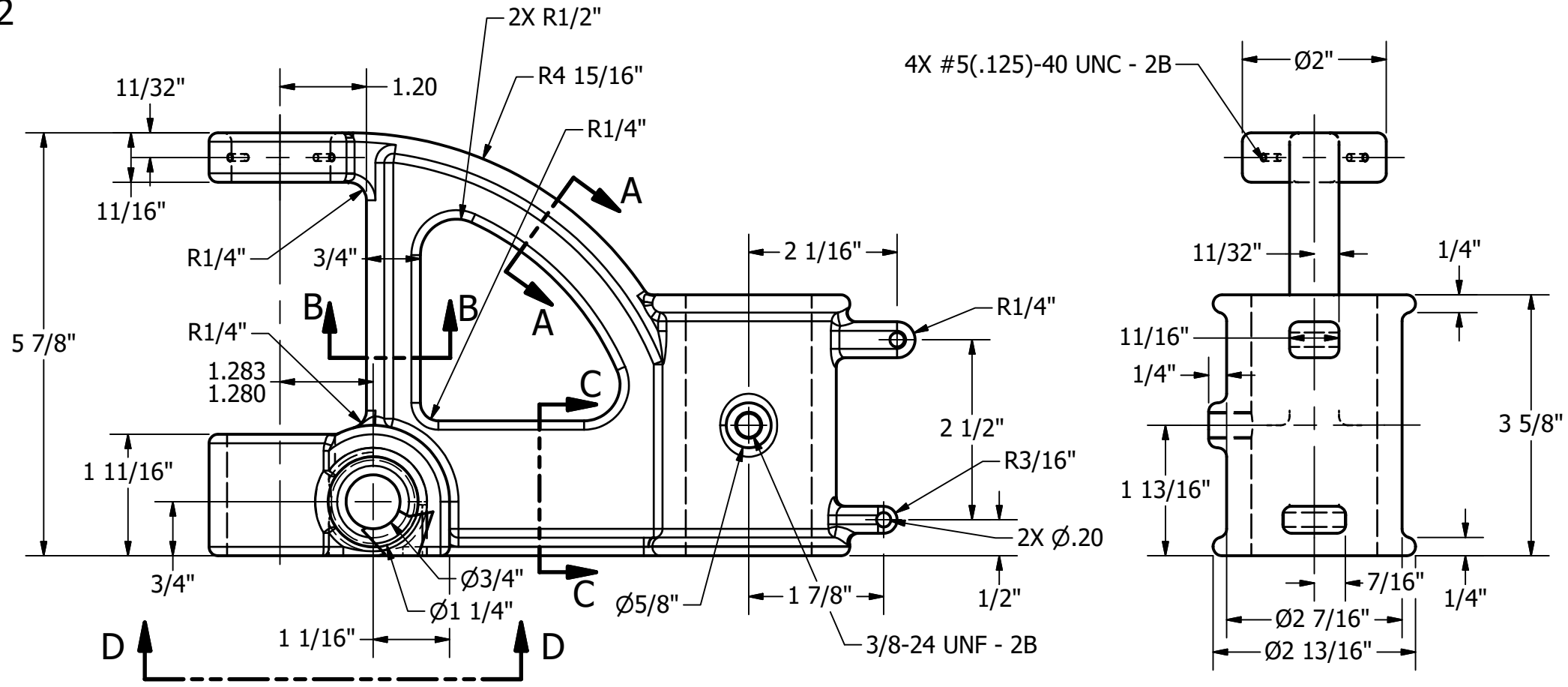

FRONT VIEW  
SCALE 1 / 2

RIGHT VIEW  
SCALE 1 / 2

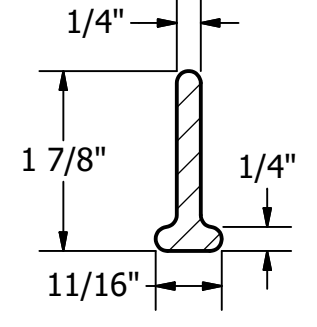

SECTION C-C  
SCALE 1 / 2

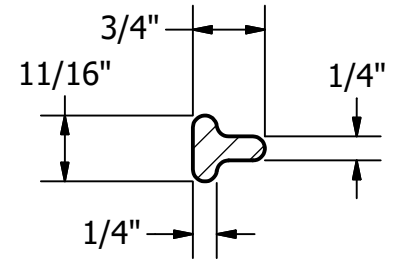

SECTION B-B  
SCALE 1 / 2

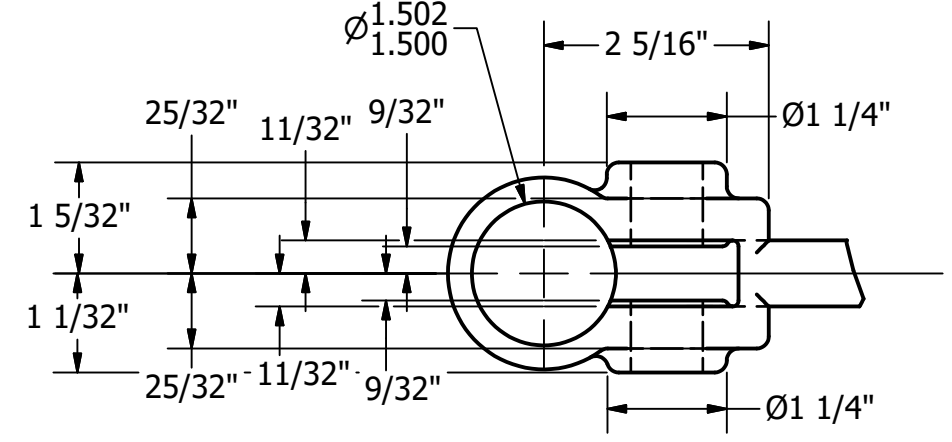

VIEW D-D  
SCALE 1 / 2

**LEGEND:**  
 $\phi$  DIAMETER  
R RADIUS  
 $^\circ$  DEGRES

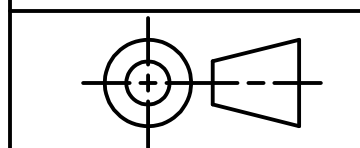

TOLERANCES UNLESS SPECIFIED:  
DECIMAL INCHES:  
X =  $\pm .020$   
XX =  $\pm .010$   
XXX =  $\pm .005$   
FRACTIONAL  $\pm 1/64$   
ANGLES  $\pm 1$  DEGREE  
SURFACES  $\checkmark$

COURSE: DDGT121

INVENTOR DRAWING NAME:  
DRILL PRESS BRACKET

FIG #: 14-35

DRAFTER: S.NAYERI

DATE: 4/9/2018

SCALE: AS NOTED

PAGE #: 1 OF 1