

PARTS LIST

ITEM	QTY.	PART NAME	MATERIAL
1	1	SHAFT BASE	MALLEABLE IRON



DIGITAL DESIGN
GRAPHICS
TECHNOLOGY

WWW.DDGT.NET

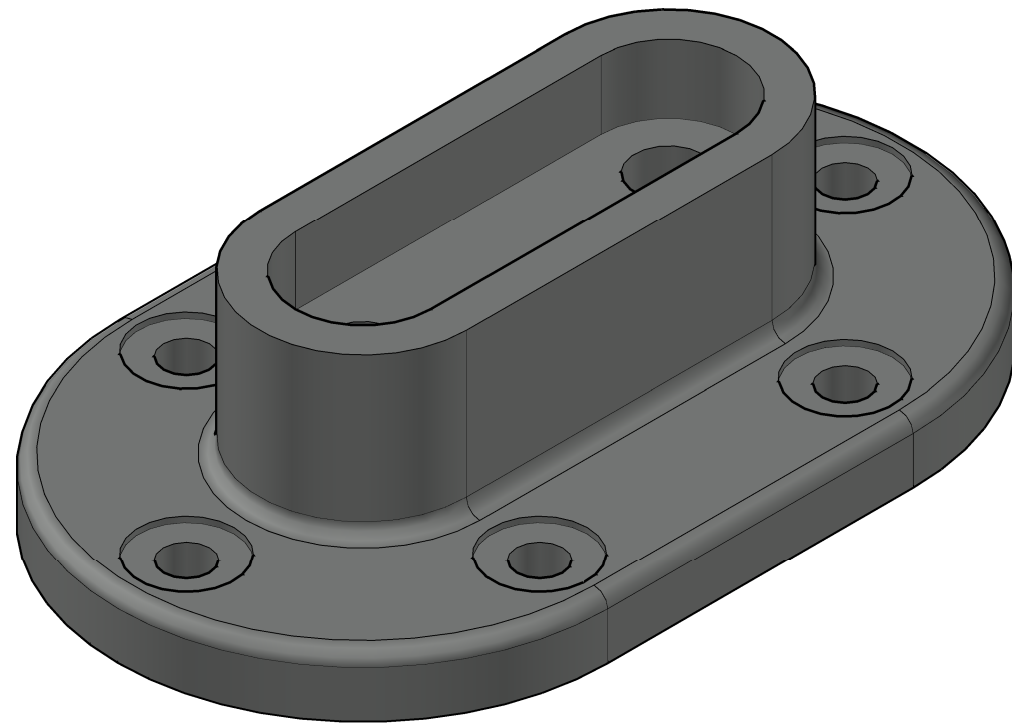

SHAFT BASE
SCALE 1:1

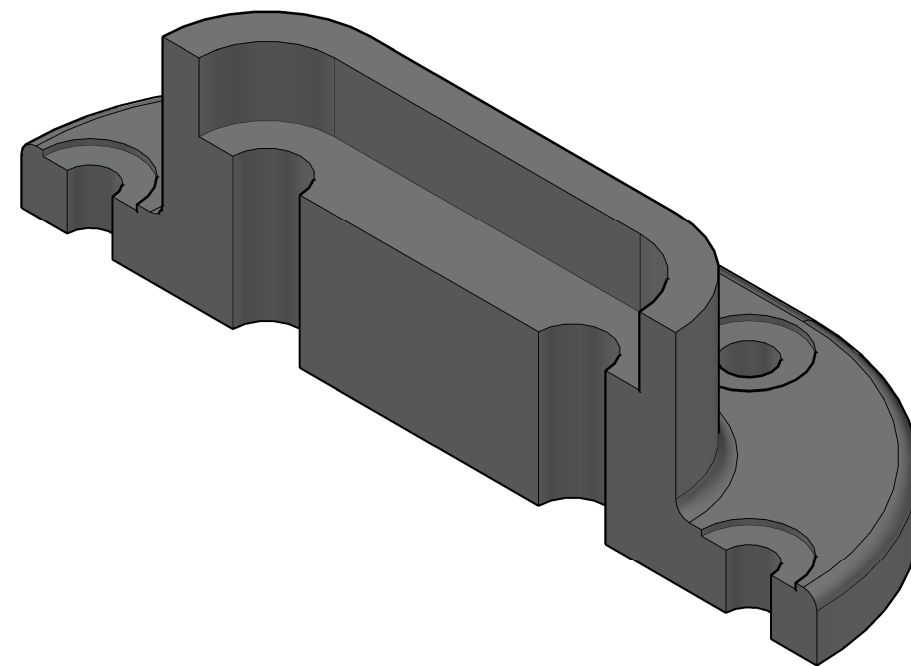

SHAFT BASE SECTION VIEW
SCALE 1:1

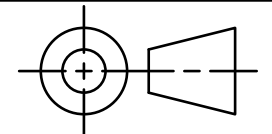

TOLERANCES UNLESS SPECIFIED:
DECIMAL INCHES:
X = ±.020
XX = ±.010
XXX = ±.005
FRACTIONAL ±1/64"
ANGLES ±1 DEGREE
SURFACES 32/

CLASS: DDGT 120

ASSIGNMENT #: #56

AUTOCAD DRAWING NAME:
Shaft Base

FIG #: 9-35

MANAGER: G. STROMMEN

DRAFTER: S. ZEPEDA

DATE: 10/24/2022

SCALE: AS NOTED

PAGE #: 1 OF 2

GENERAL NOTES:

ROUNDS AND FILLETS R.10 UNLESS
OTHERWISE STATED

LEGEND:

∅ DIAMETER
R RADIUS
| | SPOTFACE

PARTS LIST

ITEM	QTY.	PART NAME
1	1	SHAFT BASE



DIGITAL DESIGN
GRAPHICS
TECHNOLOGY

WWW.DDGT.NET

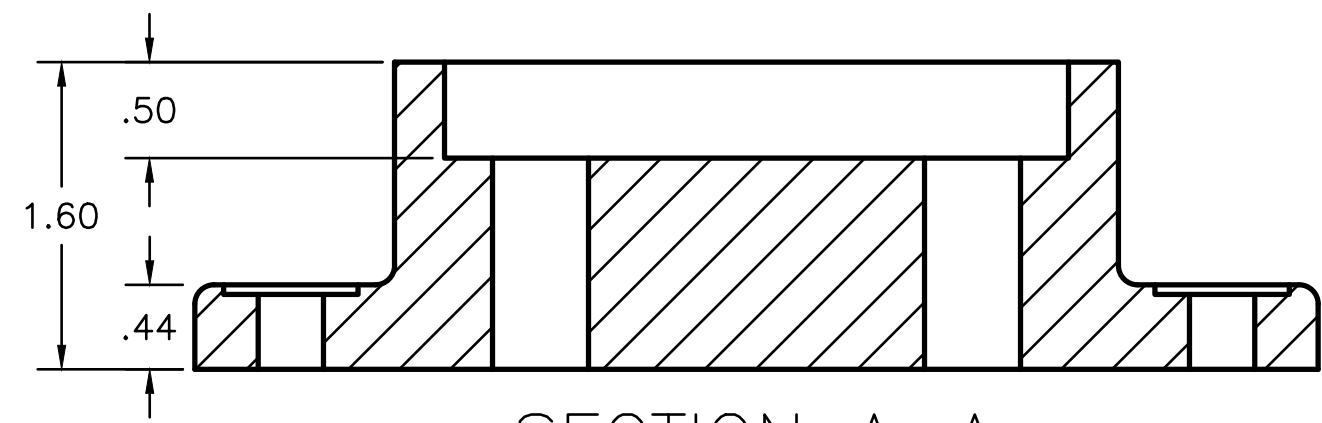
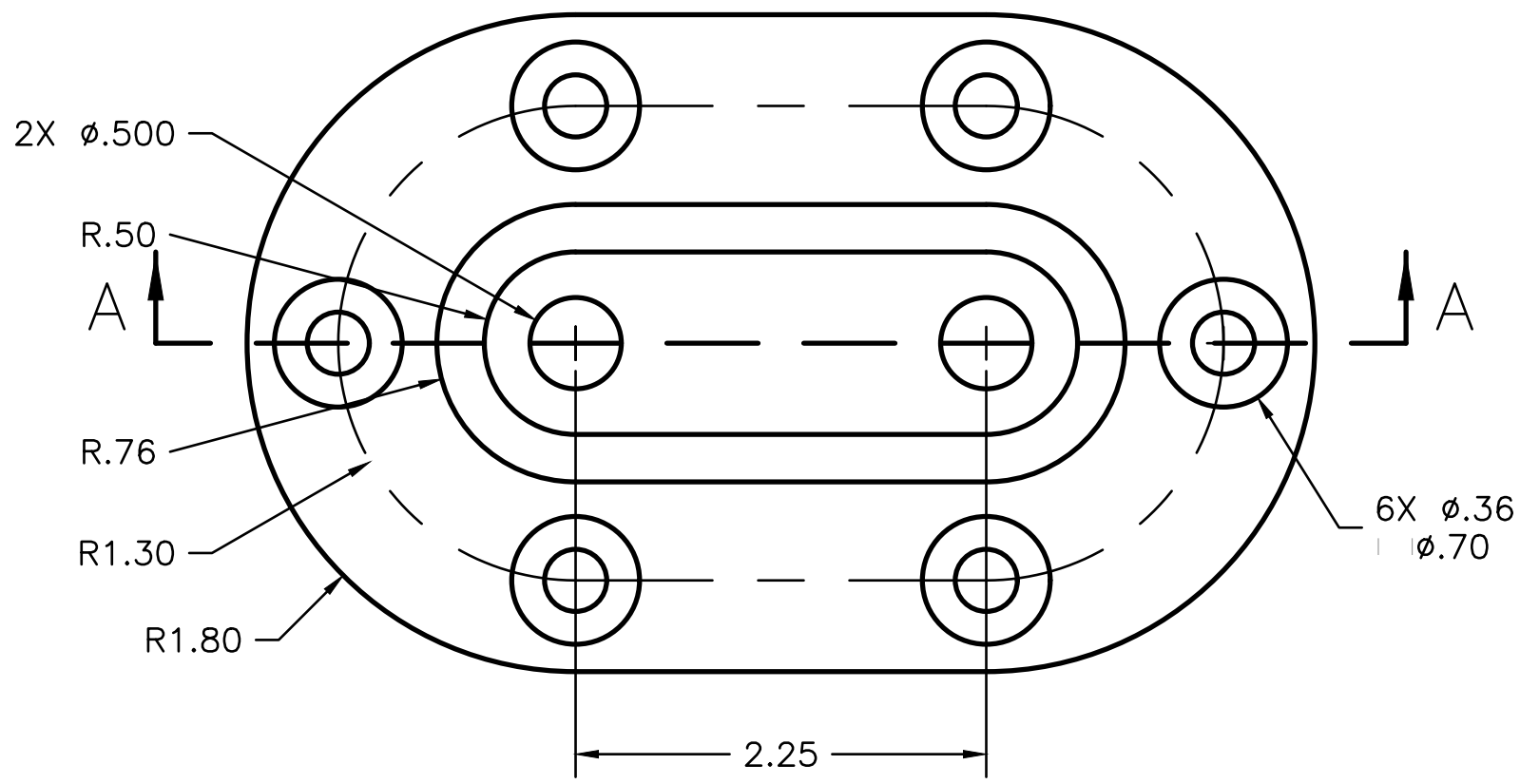

SECTION A-A

LEGEND:
 ø DIAMETER
 R RADIUS
 SPOTFACE

GENERAL NOTES:
 ROUNDS AND FILLETS R.10 UNLESS
 OTHERWISE STATED

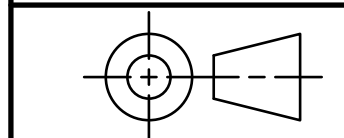

TOLERANCES UNLESS SPECIFIED:
 DECIMAL INCHES:
 X = ±.020
 XX = ±.010
 XXX = ±.005
 FRACTIONAL ±1/64"
 ANGLES ±1 DEGREE
 SURFACES 32/

CLASS: DDGT 120

ASSIGNMENT #: #56

AUTOCAD DRAWING NAME:
 Shaft Base

FIG #: 9-35

MANAGER: G. STROMMEN

DRAFTER: S. ZEPEDA

DATE: 10/24/2022

SCALE: 1:1

PAGE #: 2 OF 2