

METRIC

PARTS LIST				
ITEM	QTY	PART NUMBER	MATERIAL	DESCRIPTION
1	2	SIDE PLATE	MILD STEEL	
2	2	GUIDE	CAST IRON	
3	1	AXLE	COLD ROLLED STEEL	
4	1	HOOK	MILD SETEEL	10 THICK
5	44	ROLLER BEARING	COLD ROLLED STEEL	ø10 X 38 LONG
6	4	WHEEL	CAST IRON	
7	4	WHEEL AXLE	COLLED ROLLED STEEL	
8	12	ADJUSTING WASHER	STANDARD	ø26 ID X 44 OD X 4 THICK
9	4	RIVET	STANDARD	BUTTON HEAD, ø10 X 60 LONG
10	4	WASHER	STANDARD	ø26 ID X 65 OD X 3 THICK
11	4	LOCKNUT	STANDARD	M16 X 2 (PREVAILING TORQUE INSERT-TYPE)
12	6	COTTER PIN	STANDARD	ø6 X 40 LONG



DIGITAL DESIGN
GRAPHICS
TECHNOLOGY

WWW.DDGT.NET

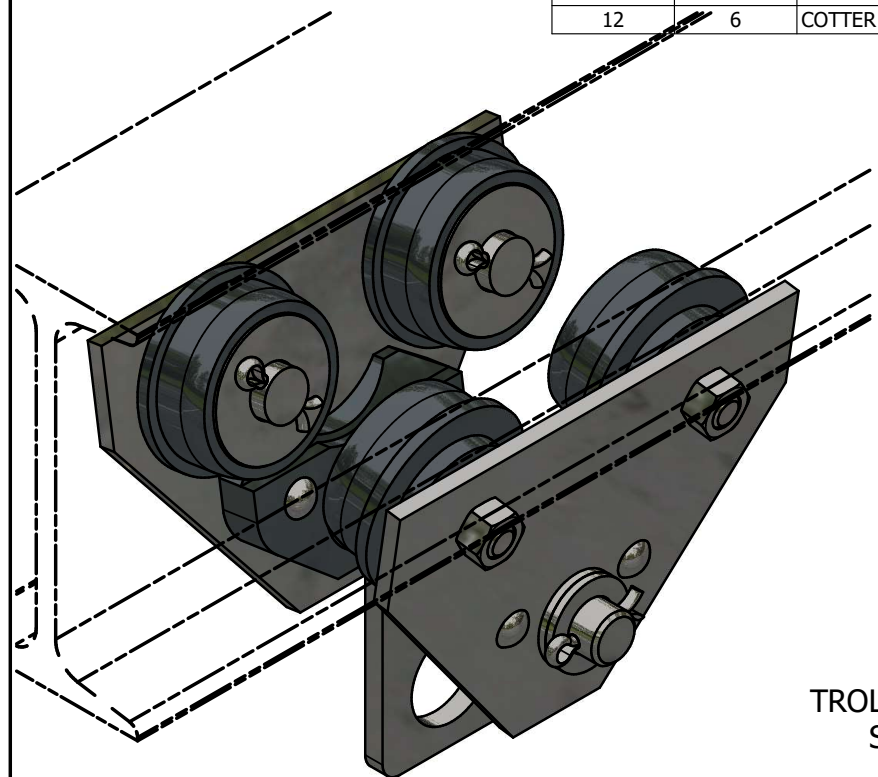

TROLLEY ASSEMBLY
SCALE 1 / 2

LEGEND:

- ∅ DIAMETER
- R RADIUS
- ° DEGREES

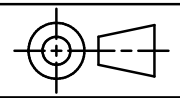

GENERAL NOTES:

TROLLEY TO BE MOUNTED ON AN S200 X 34 BEAM

ALL CHAMFERS ARE 2 X 2 UNLESS OTHERWISE NOTED

TOLERANCES UNLESS SPECIFIED
DECIMAL INCHES:
X = ±.020
XX = ±.010
XXX = ±.005
FRACTIONAL ±1/64"
ANGLES ±1 DEGREE

SURFACES $\sqrt{}$	
CLASS:	DDGT 120
ASSIGNMENT NO.:	70
INVENTOR DRAWING NAME:	TROLLEY
FIG NO.:	14-83
MANAGER:	G. STROMMEN
DRAFTER:	T. VIDALES
DATE:	12/8/2023
SCALE:	AS NOTED
PAGE NO.:	1 OF 6

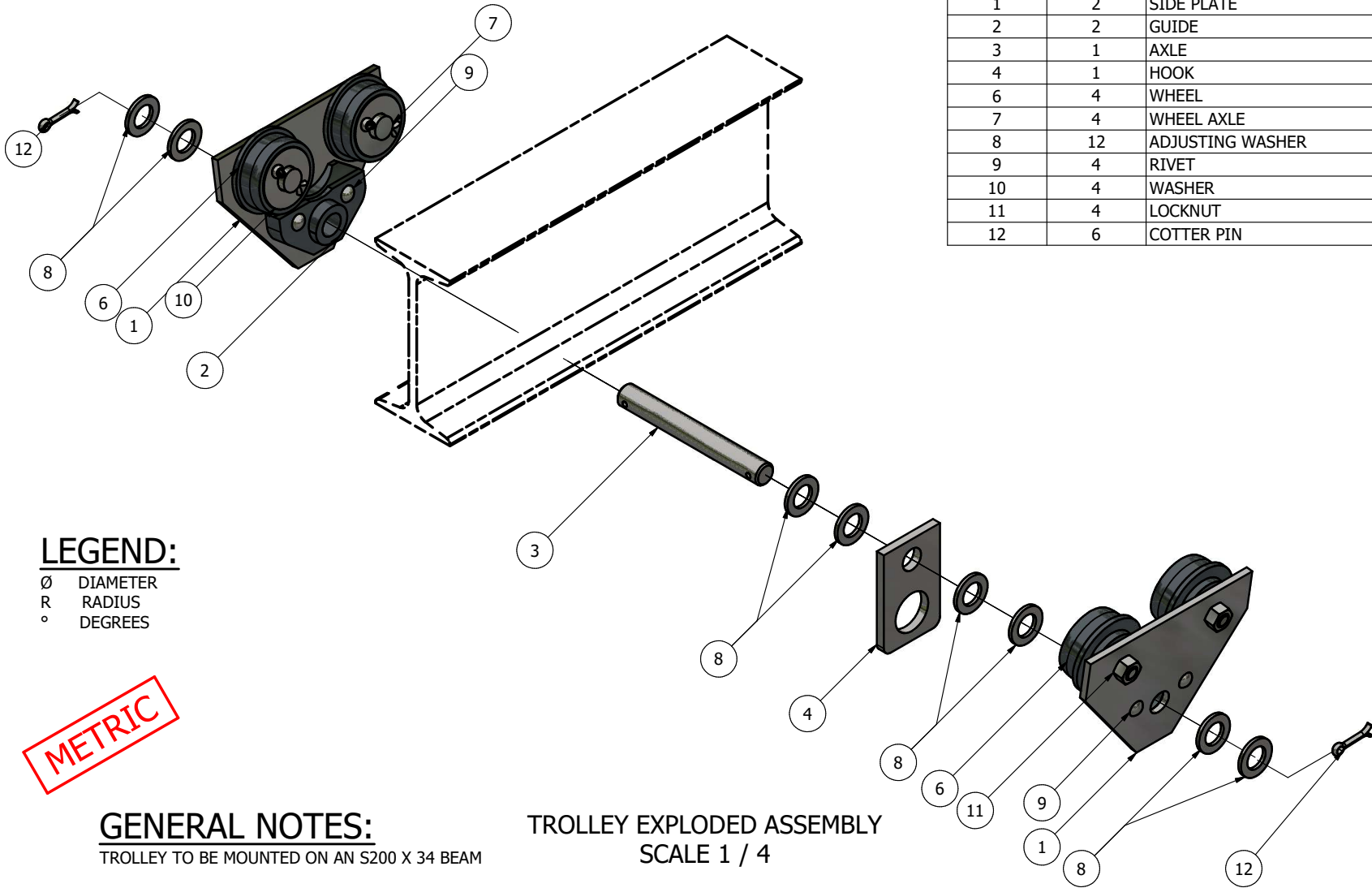

PARTS LIST		
ITEM	QTY	PART NUMBER
1	2	SIDE PLATE
2	2	GUIDE
3	1	AXLE
4	1	HOOK
6	4	WHEEL
7	4	WHEEL AXLE
8	12	ADJUSTING WASHER
9	4	RIVET
10	4	WASHER
11	4	LOCKNUT
12	6	COTTER PIN



DIGITAL DESIGN
GRAPHICS
TECHNOLOGY

WWW.DDGT.NET

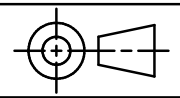

TOLERANCES UNLESS SPECIFIED
 DECIMAL INCHES:
 X = ±.020
 XX = ±.010
 XXX = ±.005
 FRACTIONAL ±1/64"
 ANGLES ±1 DEGREE
 SURFACES 32

CLASS:	DDGT 120
ASSIGNMENT NO.:	70
INVENTOR DRAWING NAME:	TROLLEY
FIG NO.:	14-83
MANAGER:	G. STROMMEN
DRAFTER:	T. VIDALES
DATE:	12/8/2023
SCALE:	AS NOTED
PAGE NO.:	2 OF 6

LEGEND:

- ∅ DIAMETER
- R RADIUS
- ° DEGREES

METRIC

GENERAL NOTES:

TROLLEY TO BE MOUNTED ON AN S200 X 34 BEAM

ALL CHAMFERS ARE 2 X 2 UNLESS OTHERWISE NOTED

**TROLLEY EXPLODED ASSEMBLY
SCALE 1 / 4**

METRIC

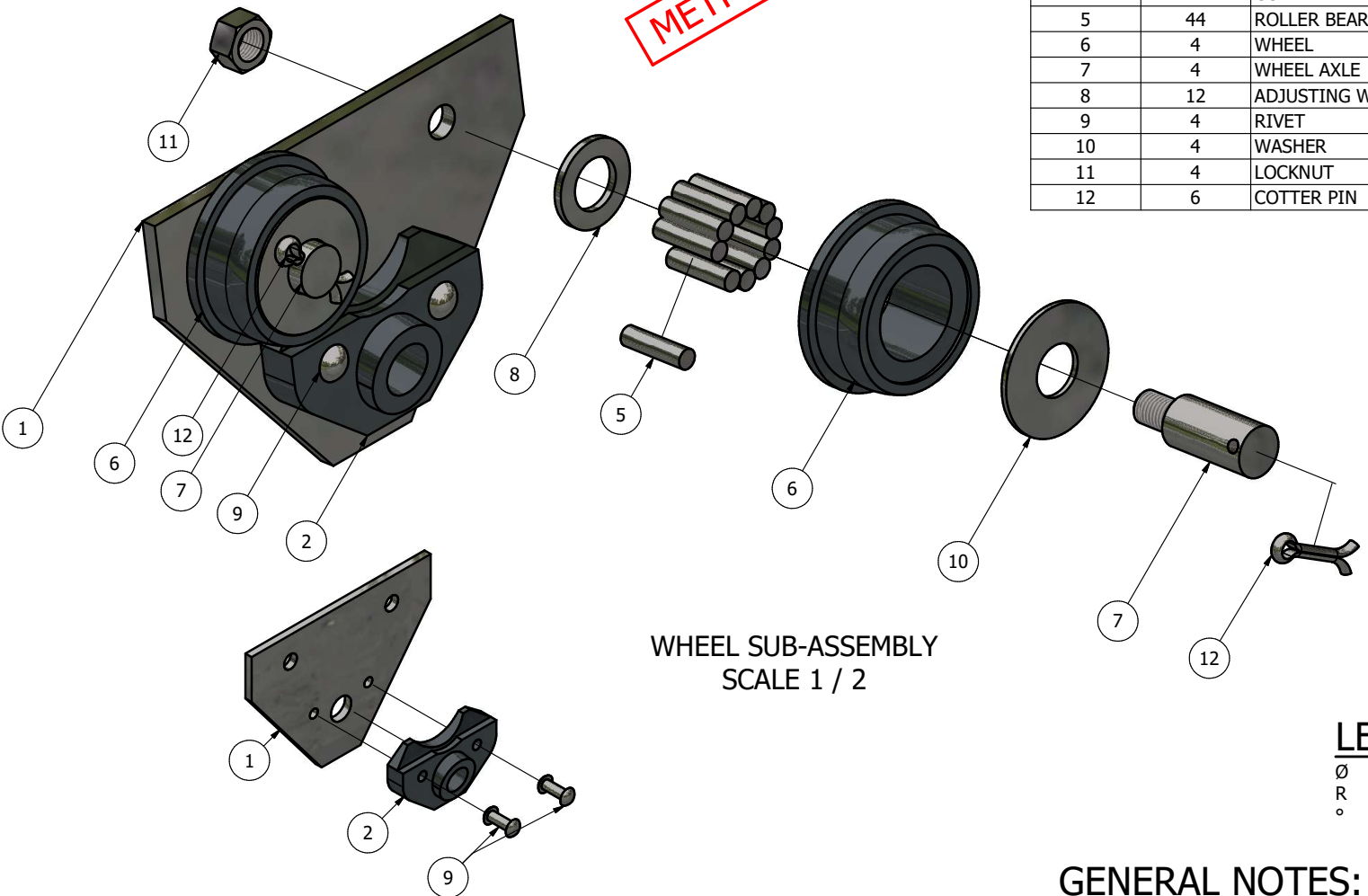

WHEEL SUB-ASSEMBLY
SCALE 1 / 2

SIDE PLATE SUB-ASSEMBLY
SCALE 1 / 4

PARTS LIST		
ITEM	QTY	PART NUMBER
1	2	SIDE PLATE
2	2	GUIDE
5	44	ROLLER BEARING
6	4	WHEEL
7	4	WHEEL AXLE
8	12	ADJUSTING WASHER
9	4	RIVET
10	4	WASHER
11	4	LOCKNUT
12	6	COTTER PIN



DIGITAL DESIGN
GRAPHICS
TECHNOLOGY

WWW.DDGT.NET

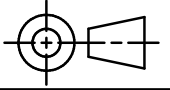

TOLERANCES UNLESS SPECIFIED
 DECIMAL INCHES:
 X = ±.020
 XX = ±.010
 XXX = ±.005
 FRACTIONAL ±1/64"
 ANGLES ±1 DEGREE
 SURFACES $\sqrt{}$

LEGEND:

- Ø DIAMETER
- R RADIUS
- ° DEGREES

GENERAL NOTES:

TROLLEY TO BE MOUNTED ON AN S200 X 34 BEAM
 ALL CHAMFERS ARE 2 X 2 UNLESS OTHERWISE NOTED

CLASS:	DDGT 120
ASSIGNMENT NO.:	70
INVENTOR DRAWING NAME:	TROLLEY
FIG NO.:	14-83
MANAGER:	G. STROMMEN
DRAFTER:	T. VIDALES
DATE:	12/8/2023
SCALE:	AS NOTED
PAGE NO.:	3 OF 6

PARTS LIST				
ITEM	QTY	PART NUMBER	MATERIAL	DESCRIPTION
1	2	SIDE PLATE	MILD STEEL	

DDGT

DIGITAL DESIGN
GRAPHICS
TECHNOLOGY

WWW.DDGT.NET

METRIC

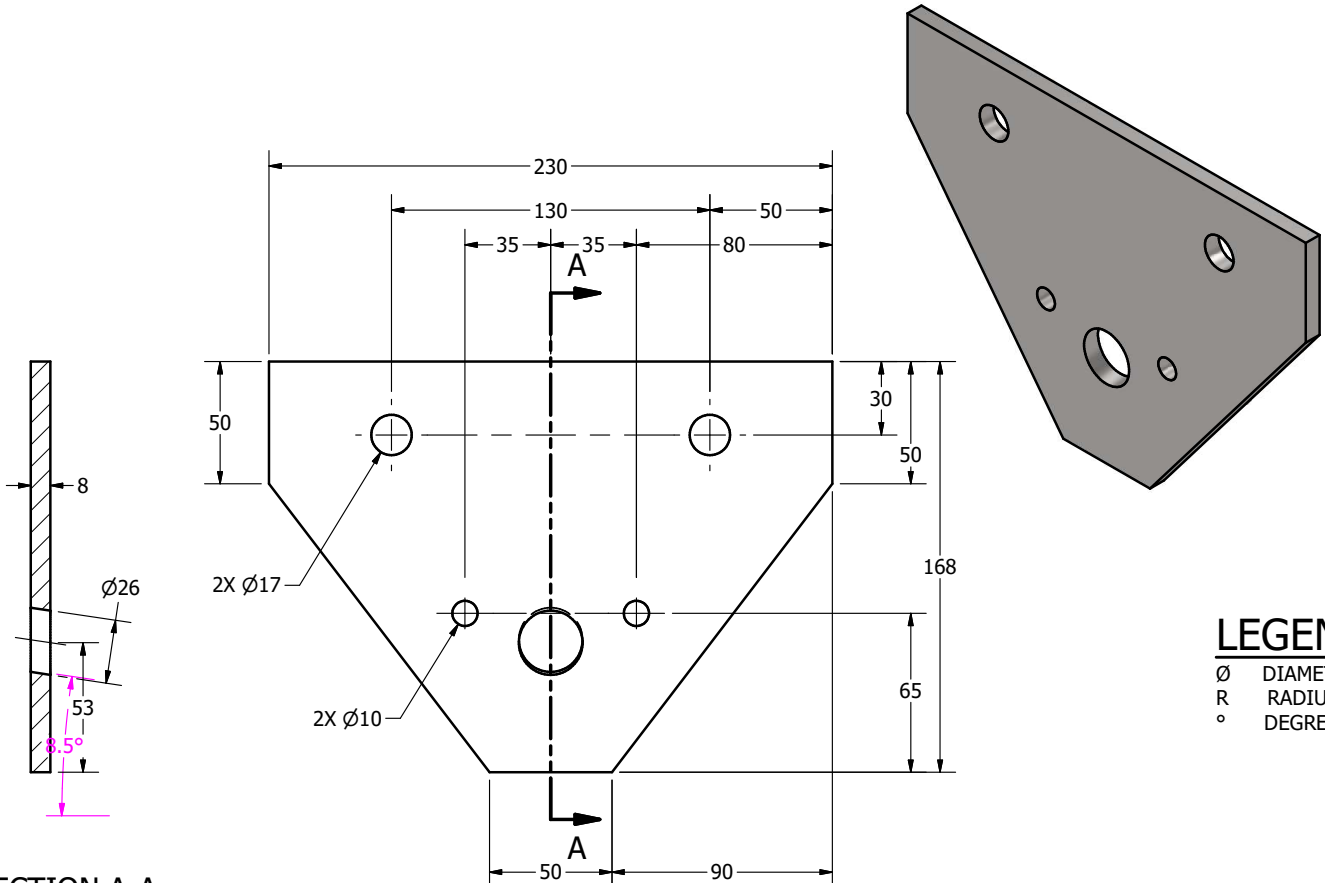

SECTION A-A
SCALE 1 / 2

SIDE PLATE
SCALE 1 / 2

LEGEND:
 Ø DIAMETER
 R RADIUS
 ° DEGREES

GENERAL NOTES:
 TROLLEY TO BE MOUNTED ON AN S200 X 34 BEAM
 ALL CHAMFERS ARE 2 X 2 UNLESS OTHERWISE NOTED

TOLERANCES UNLESS SPECIFIED	
DECIMAL INCHES:	
X	= ±.020
XX	= ±.010
XXX	= ±.005
FRACTIONAL	±1/64"
ANGLES	±1 DEGREE
SURFACES $\sqrt{32}$	
CLASS:	DDGT 120
ASSIGNMENT NO.:	70
INVENTOR DRAWING NAME:	
TROLLEY	
FIG NO.:	14-83
MANAGER:	G. STROMMEN
DRAFTER:	T. VIDALES
DATE:	12/8/2023
SCALE:	AS NOTED
PAGE NO.:	4 OF 6

METRIC

LEGEND:

∅ DIAMETER
R RADIUS
° DEGREES

GENERAL NOTES:

TROLLEY TO BE MOUNTED ON AN S200 X 34 BEAM
ALL CHAMFERS ARE 2 X 2 UNLESS OTHERWISE NOTED

PARTS LIST

ITEM	QTY	PART NUMBER
3	1	AXLE
2	2	GUIDE

DDGT

DIGITAL DESIGN
GRAPHICS
TECHNOLOGY

WWW.DDGT.NET

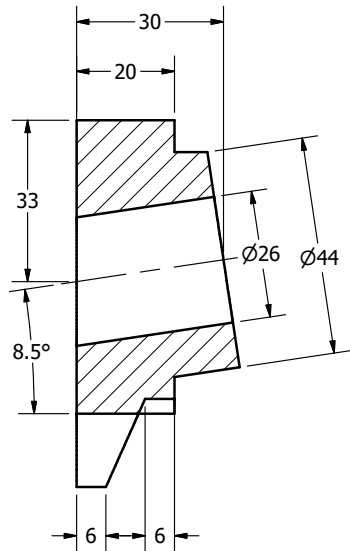

SECTION B-B
SCALE 1 : 1

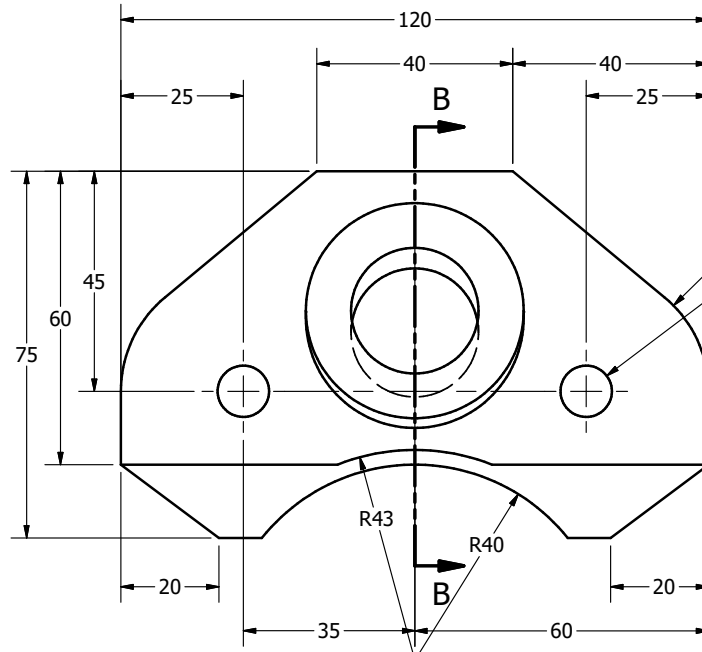

GUIDE
SCALE 1 : 1

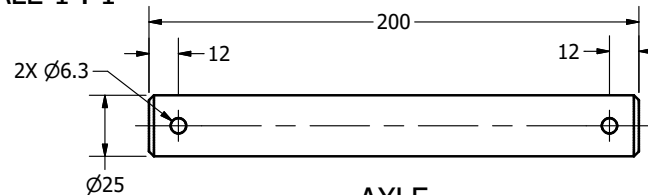
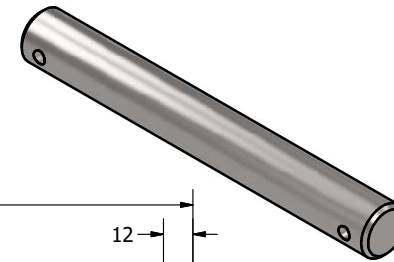
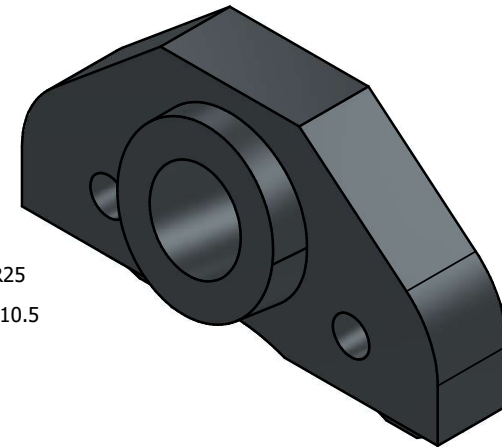

AXLE
SCALE 1 / 2

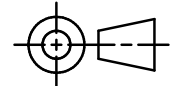

TOLERANCES UNLESS SPECIFIED
DECIMAL INCHES:
X = ±.020
XX = ±.010
XXX = ±.005
FRACTIONAL ±1/64"
ANGLES ±1 DEGREE
SURFACES 32 ✓

CLASS: DDGT 120

ASSIGNMENT NO.: 70

INVENTOR DRAWING NAME:

TROLLEY

FIG NO.: 14-83

MANAGER: G. STROMMEN

DRAFTER: T. VIDALES

DATE: 12/8/2023

SCALE: AS NOTED

PAGE NO.: 5 OF 6

PARTS LIST

ITEM	QTY	PART NUMBER
4	1	HOOK
6	4	WHEEL
7	4	WHEEL AXLE



DIGITAL DESIGN
GRAPHICS
TECHNOLOGY

WWW.DDGT.NET

GENERAL NOTES:

TROLLEY TO BE MOUNTED ON AN S200 X 34 BEAM

ALL CHAMFERS ARE 2 X 2 UNLESS OTHERWISE NOTED

METRIC

LEGEND:

- Ø DIAMETER
- R RADIUS
- ° DEGREES

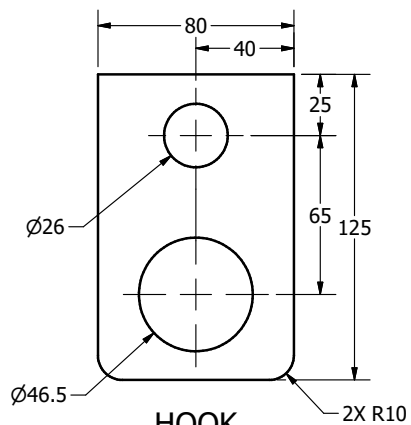

HOOK
SCALE 1 / 2

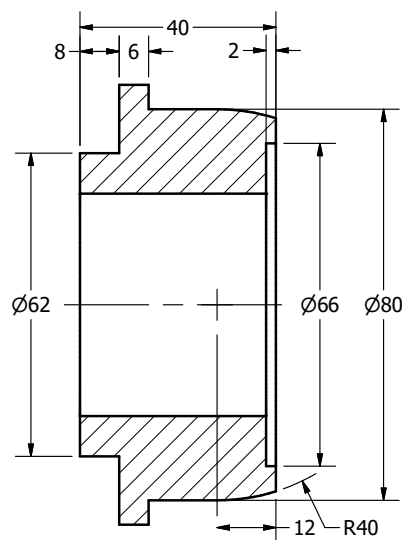
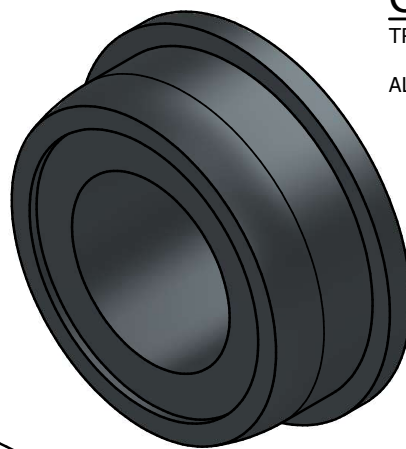
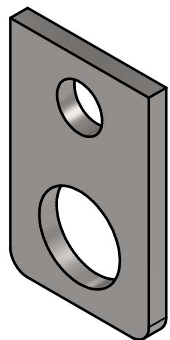

SECTION C-C
SCALE 1 : 1

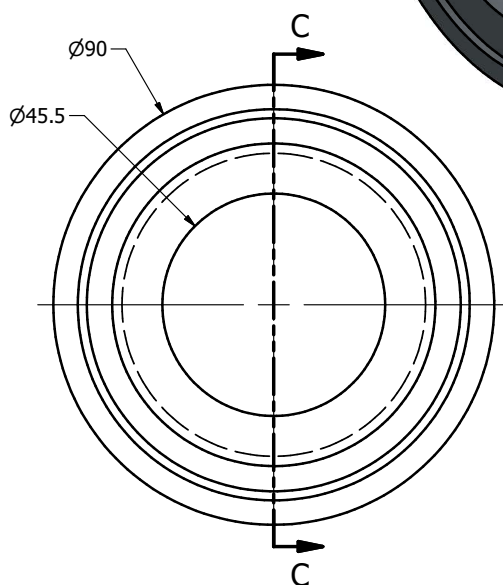

WHEEL
SCALE 1 : 1

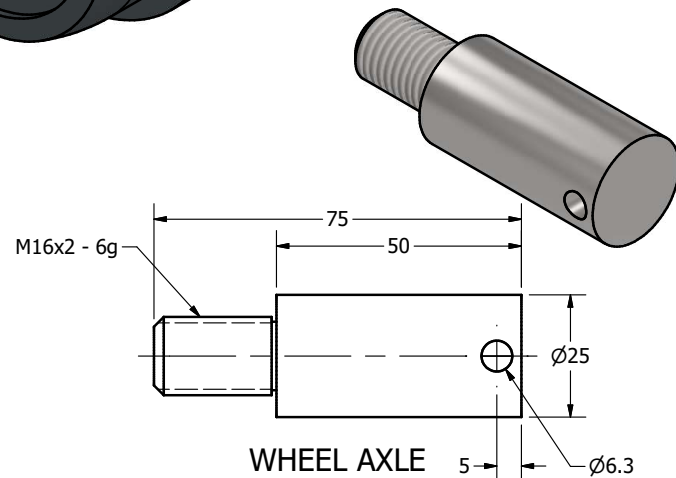

WHEEL AXLE
SCALE 1 : 1

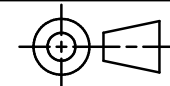

TOLERANCES UNLESS SPECIFIED
DECIMAL INCHES:
X = ±.020
XX = ±.010
XXX = ±.005
FRACTIONAL ±1/64"
ANGLES ±1 DEGREE
SURFACES 32 ✓

CLASS:	DDGT 120
ASSIGNMENT NO.:	70
INVENTOR DRAWING NAME:	TROLLEY
FIG NO.:	14-83
MANAGER:	G. STROMMEN
DRAFTER:	T. VIDALES
DATE:	12/8/2023
SCALE:	AS NOTED
PAGE NO.:	6 OF 6