

LEGEND:

- ° DEGREES
- ∅ DIAMETER
- R RADIUS
- ⌊ SPOTFACE
- ∇ DEPTH

PARTS LIST

| ITEM | QTY. | PART NAME | MATERIAL |
|------|------|-----------|----------|
| 1 | 1 | CASING | SAE 1012 |

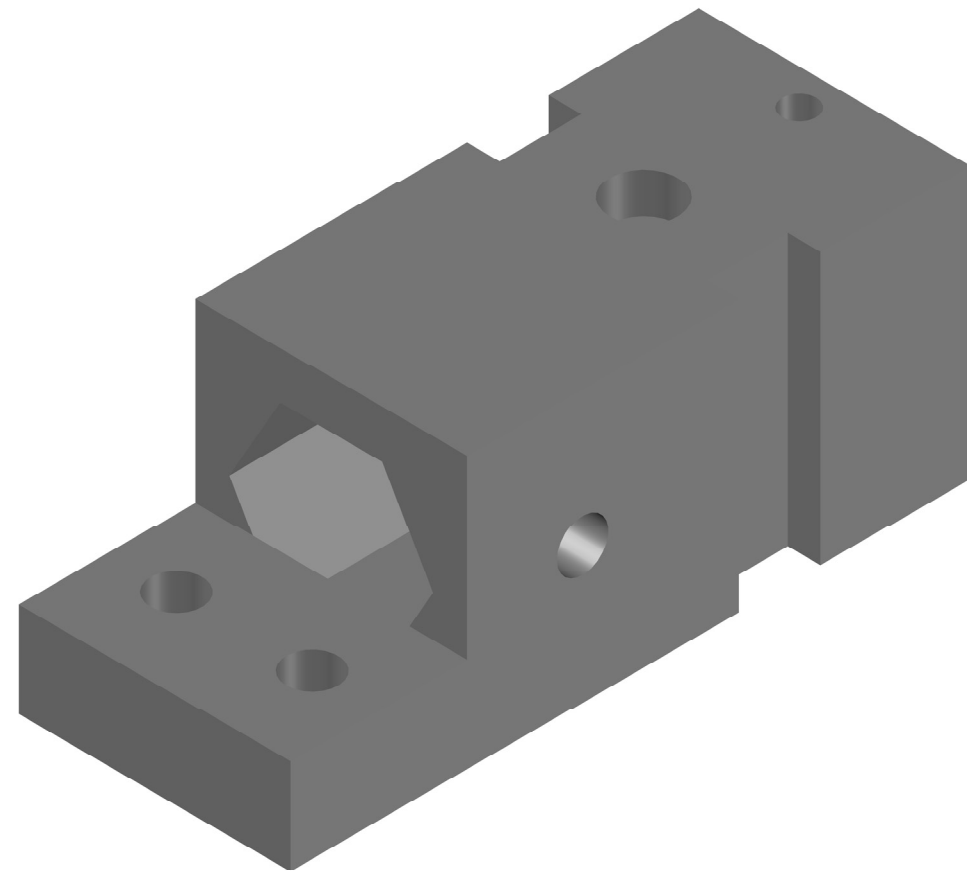

CASING
SCALE 1:1

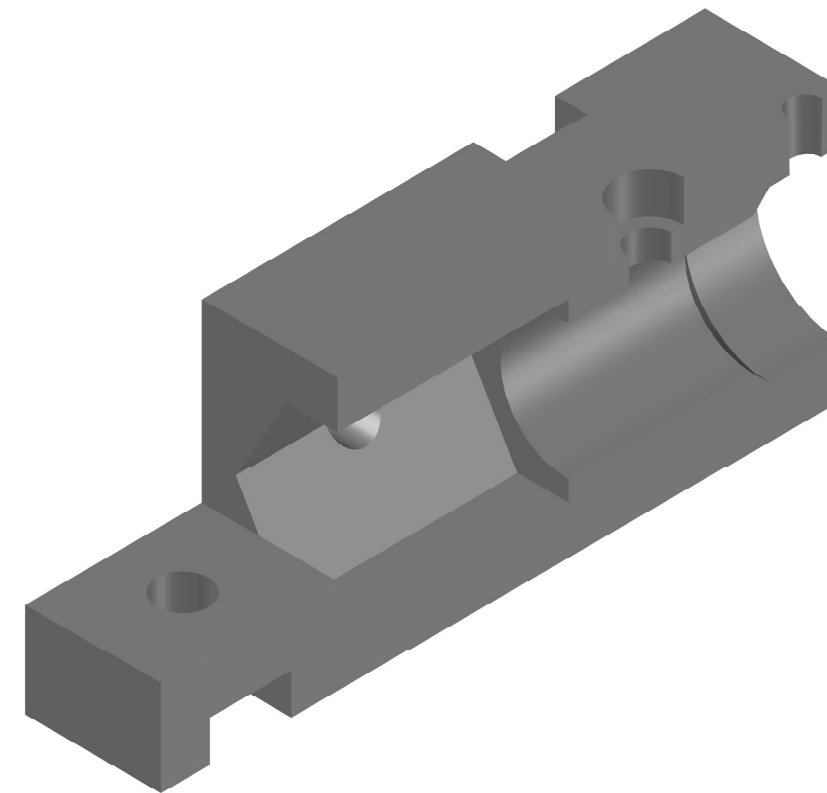

CASING SECTION
VIEW SCALE 1:1

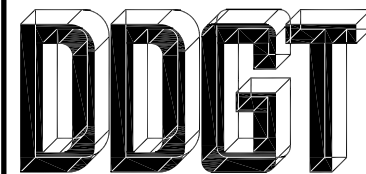

DIGITAL DESIGN
GRAPHICS
TECHNOLOGY

WWW.DDGT.NET

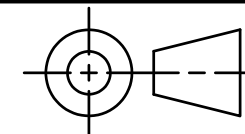

TOLERANCES UNLESS SPECIFIED:
 DECIMAL INCHES:
 X = ±.020
 XX = ±.010
 XXX = ±.005
 FRACTIONAL ±1/64"
 ANGLES ±1 DEGREE
 SURFACES 32 ✓

COURSE: DDGT120

AUTOCAD DRAWING NAME:
CASING

FIG #: FIG 9-39

DRAFTER: W. VALLADARES

DATE: 11/20/2018

SCALE: AS NOTED

PAGE #: 1 OF 2

PARTS LIST

| ITEM | QTY. | PART NAME | MATERIAL |
|------|------|-----------|----------|
| 1 | 1 | CASING | SAE 1012 |

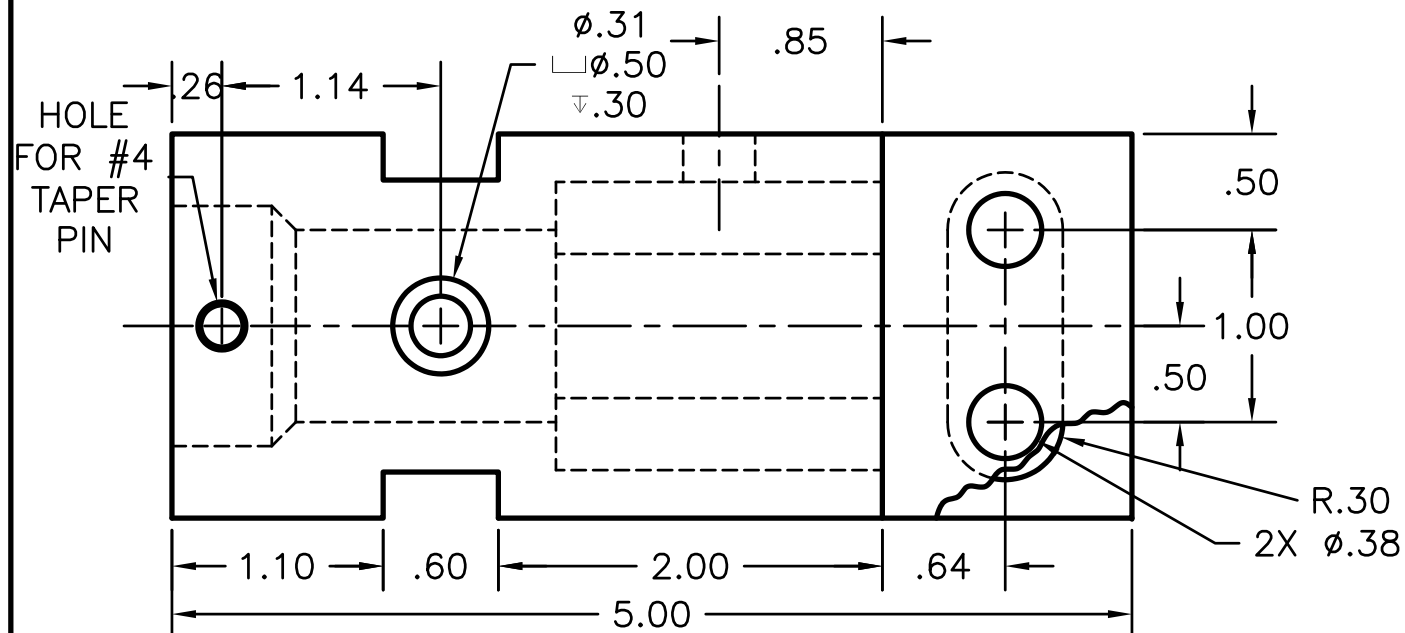

LEGEND:

- ° DEGREES
- ϕ DIAMETER
- R RADIUS
- \square SPOTFACE
- ∇ DEPTH

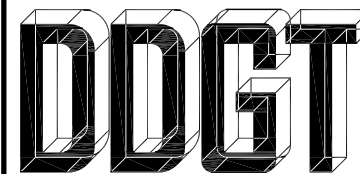
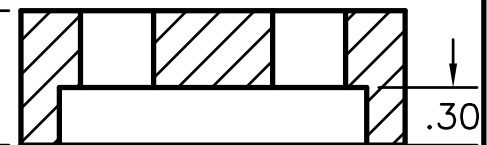
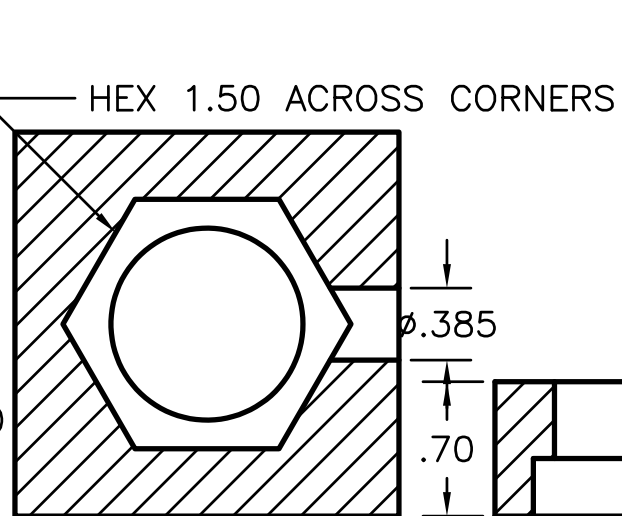
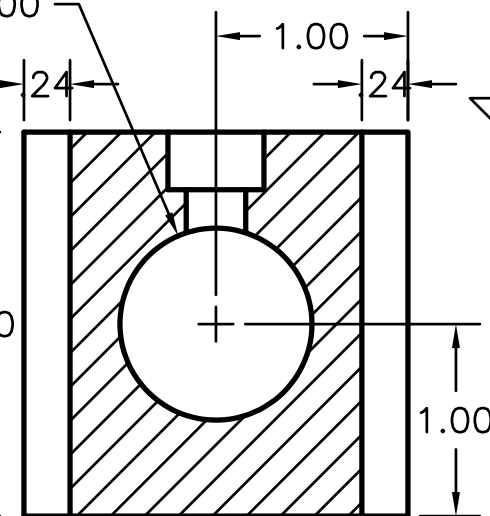
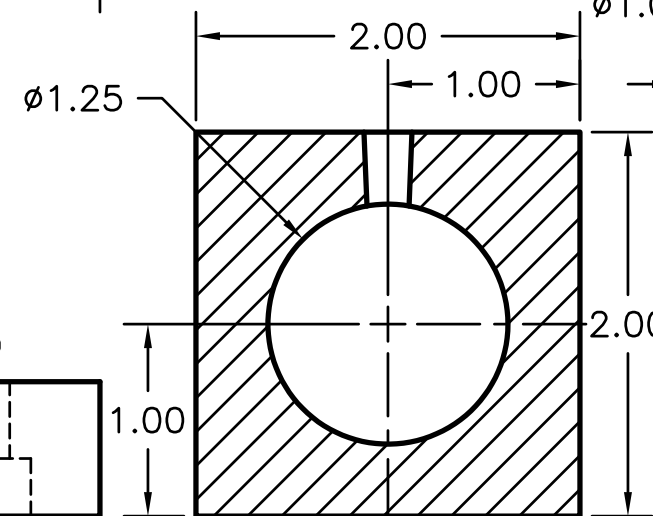
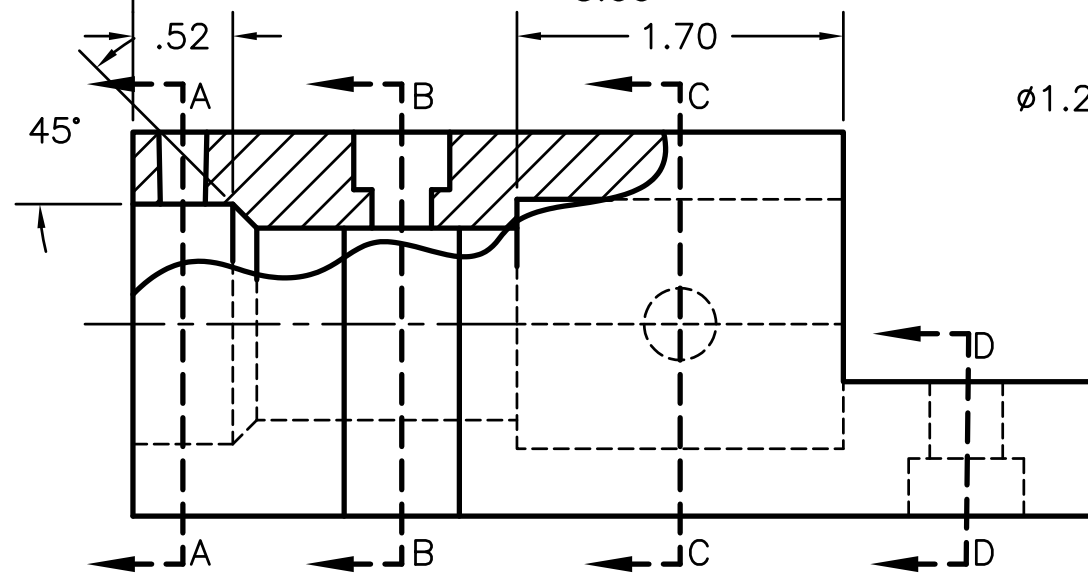

DIGITAL DESIGN
GRAPHICS
TECHNOLOGY

WWW.DDGT.NET

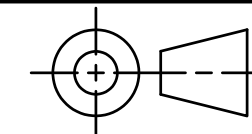

TOLERANCES UNLESS SPECIFIED:
DECIMAL INCHES:
X = $\pm .020$
XX = $\pm .010$
XXX = $\pm .005$
FRACTIONAL $\pm 1/64$ "
ANGLES ± 1 DEGREE
SURFACES $\frac{32}{\checkmark}$

COURSE: DDGT120

AUTOCAD DRAWING NAME:
CASING

FIG #: FIG 9-39

DRAFTER: W. VALLADARES

DATE: 11/20/2018

SCALE: 1:1

PAGE #: 2 OF 2