

PARTS LIST				
ITEM	QTY	PART NUMBER	MATERIAL	DESCRIPTION
1	2	SIDE PLATE SUB ASSEMBLY		SUB-ASSEMBLY
1.1	2	SIDE PLATE	MILD STEEL	
1.2	2	GUIDE	CAST IRON	
1.3	4	RIVET	STANDARD	BUTTON HEAD, Ø10 x 60LG
2	1	HOOK	MILD STEEL	
3	4	WHEEL	CAST IRON	
4	1	AXLE	COLD ROLLED STEEL	
5	4	WHEEL AXLE	COLD ROLLED STEEL	
6	44	ROLLER BEARING	COLD ROLLED STEEL	
7	6	COTTER PIN	STANDARD	Ø6 X 40LG
8	4	LOCKNUT	STANDARD	M16 X 2 (PREVAILING TORQUE INSTER TYPE)
9	8	ADJUSTING WASHER	STANDARD	Ø26ID X Ø44OD X 4THK
10	4	WASHER	STANDARD	Ø26ID X Ø65OD X 3THK

GENERAL NOTES:

TROLLEY ASSEMBLY TO BE MOUNTED TO S200 X 34 BEAM

LEGEND:

- Ø DIAMETER
- R RADIUS
- ° DEGREES
- └─ SPOTFACE

TROLLEY
SCALE 1 / 2

METRIC



DIGITAL DESIGN
GRAPHICS
TECHNOLOGY

WWW.DDGT.NET

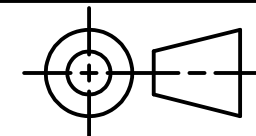

TOLERANCES UNLESS SPECIFIED:
MILLIMETERS
WHOLE NUMBER = ±.5
X = ±.25
XX = ±.12

ANGLE ±1 DEGREE

SURFACES ³² ✓

COURSE: DDGT120

INVENTOR DRAWING NAME
TROLLEY

FIG #: 14-83

DRAFTER: W.VALLADARES

DATE: 12/11/2018

SCALE: AS NOTED

PAGE #: 1 OF 6

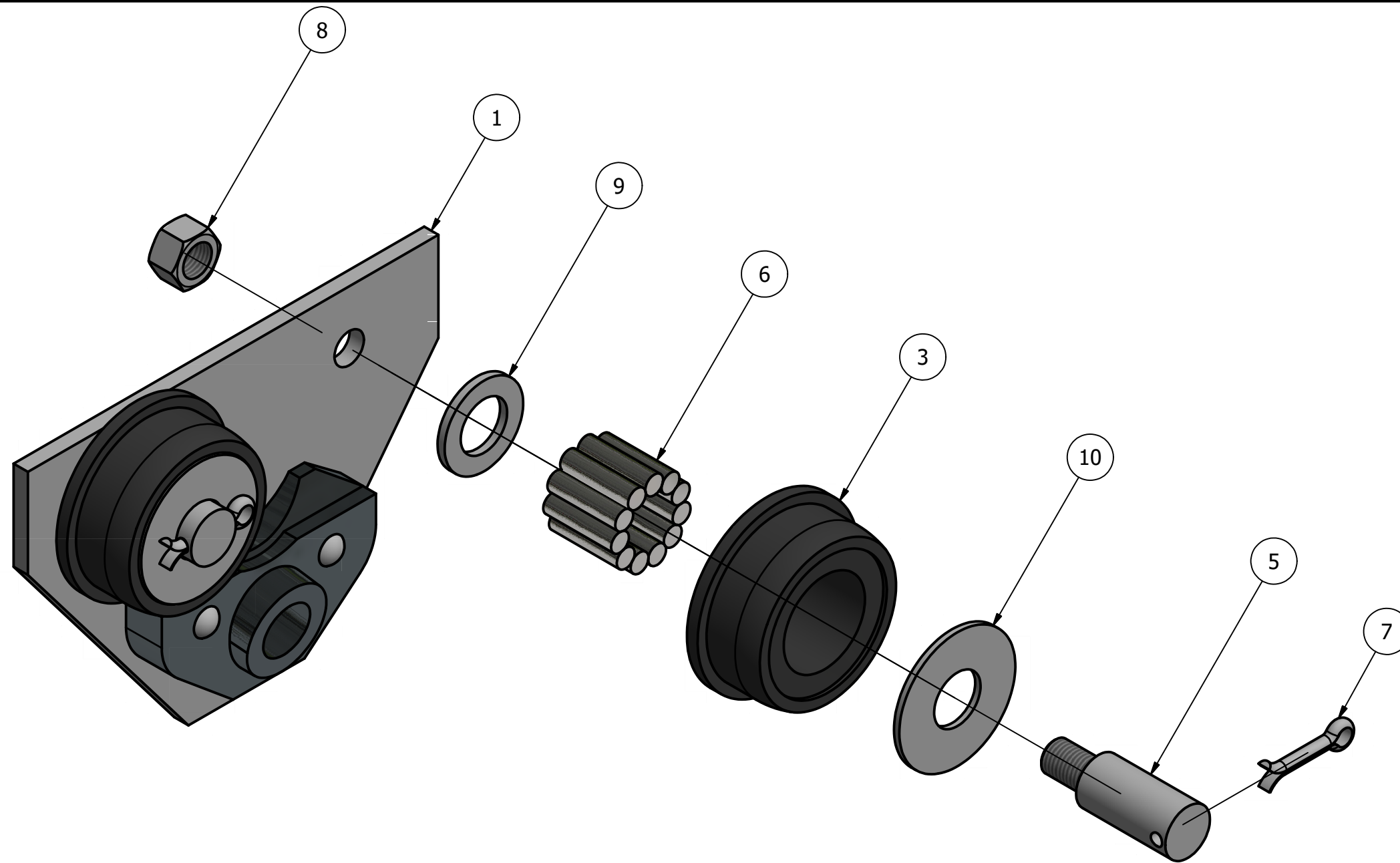

SIDE PLATE EXPLODED ASSEMBLY
SCALE 1 / 2

PARTS LIST		
ITEM	QTY	PART NUMBER
1	2	SIDE PLATE SUB ASSEMBLY
1.2	2	GUIDE
1.3	4	RIVET
1.1	2	SIDE PLATE
2	1	HOOK
3	4	WHEEL
4	1	AXLE
5	4	WHEEL AXLE
6	44	ROLLER BEARING
7	6	COTTER PIN
8	4	LOCKNUT
9	8	ADJUSTING WASHER
10	4	WASHER

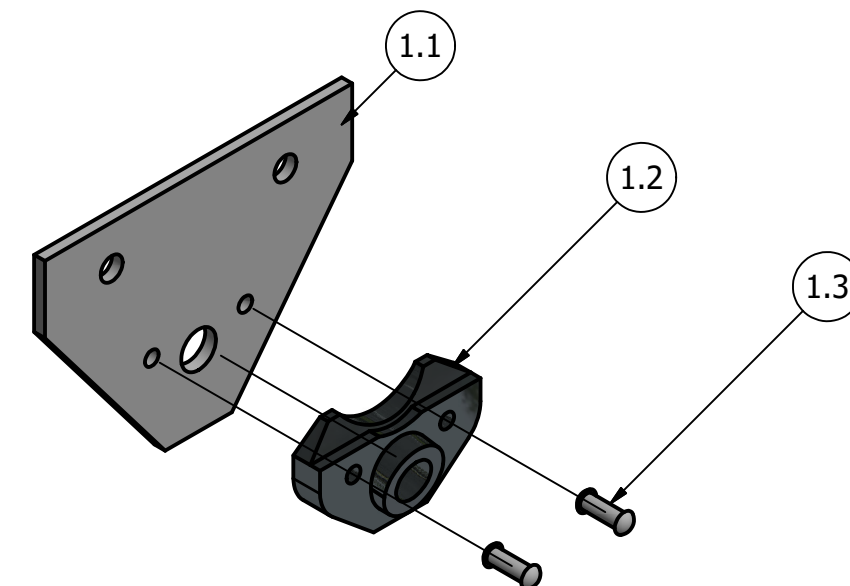

SIDE PLATE EXPLODED SUB-ASSEMBLY
SCALE 1 / 4

LEGEND:

- ∅ DIAMETER
- R RADIUS
- ° DEGREES
- ⌊ SPOTFACE



DIGITAL DESIGN
GRAPHICS
TECHNOLOGY

WWW.DDGT.NET

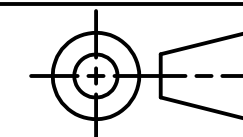

TOLERANCES UNLESS SPECIFIED:
MILLIMETERS
WHOLE NUMBER = ±.5
X = ±.25
XX = ±.12

ANGLE ±1 DEGREE

SURFACES $\sqrt{32}$

COURSE: DDGT120

INVENTOR DRAWING NAME
TROLLEY

FIG #: 14-83

DRAFTER: W.VALLADARES

DATE: 12/11/2018

SCALE: AS NOTED

PAGE #: 2 OF 6

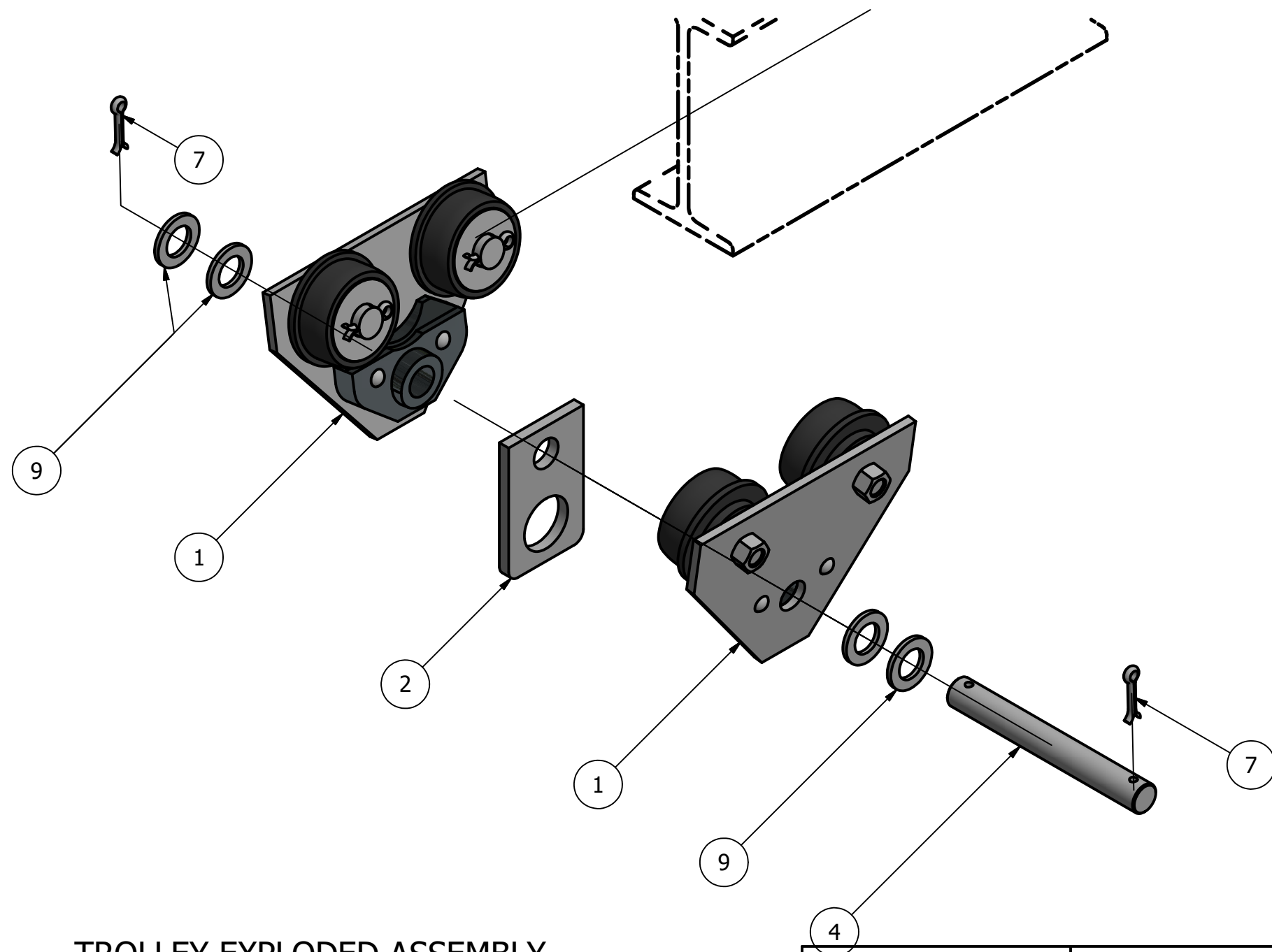

PARTS LIST		
ITEM	QTY	PART NUMBER
1	2	SIDE PLATE SUB ASSEMBLY
1.2	2	GUIDE
1.3	4	RIVET
1.1	2	SIDE PLATE
2	1	HOOK
3	4	WHEEL
4	1	AXLE
5	4	WHEEL AXLE
6	44	ROLLER BEARING
7	6	COTTER PIN
8	4	LOCKNUT
9	8	ADJUSTING WASHER
10	4	WASHER

LEGEND:

- ∅ DIAMETER
- R RADIUS
- ° DEGREES
- ┌ SPOTFACE

TROLLEY EXPLODED ASSEMBLY
SCALE 1 / 4



DIGITAL DESIGN
GRAPHICS
TECHNOLOGY

WWW.DDGT.NET

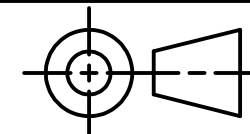

TOLERANCES UNLESS SPECIFIED:
MILLIMETERS
WHOLE NUMBER = ±.5
X = ±.25
XX = ±.12

ANGLE ±1 DEGREE

SURFACES ³² ✓

COURSE: DDGT120

INVENTOR DRAWING NAME
TROLLEY

FIG #: 14-83

DRAFTER: W.VALLADARES

DATE: 12/11/2018

SCALE: AS NOTED

PAGE #: 3 OF 6

PARTS LIST		
ITEM	QTY	PART NUMBER
1.1	4	SIDE PLATE

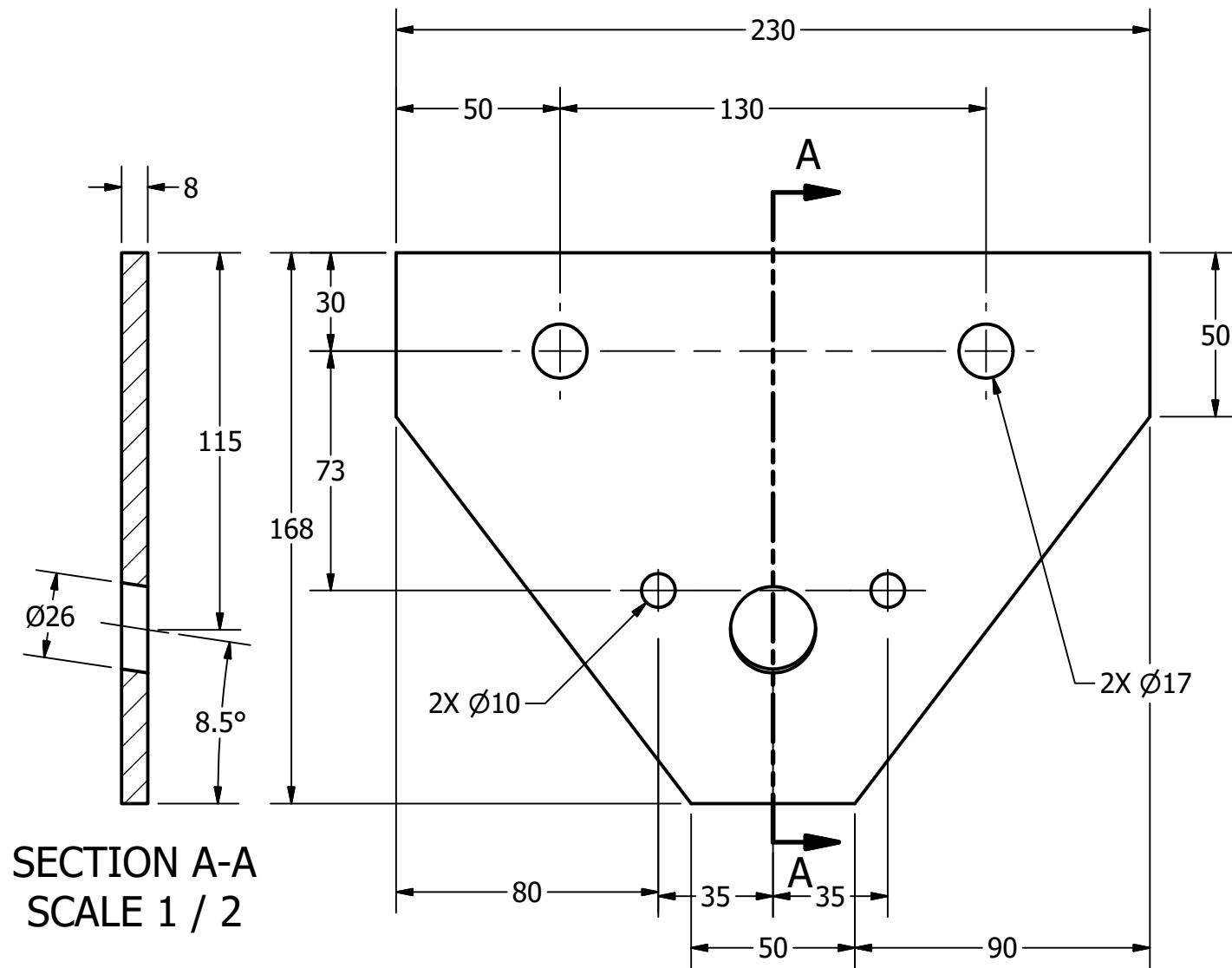

SECTION A-A
SCALE 1 / 2

SIDE PLATE
SCALE 1 / 2

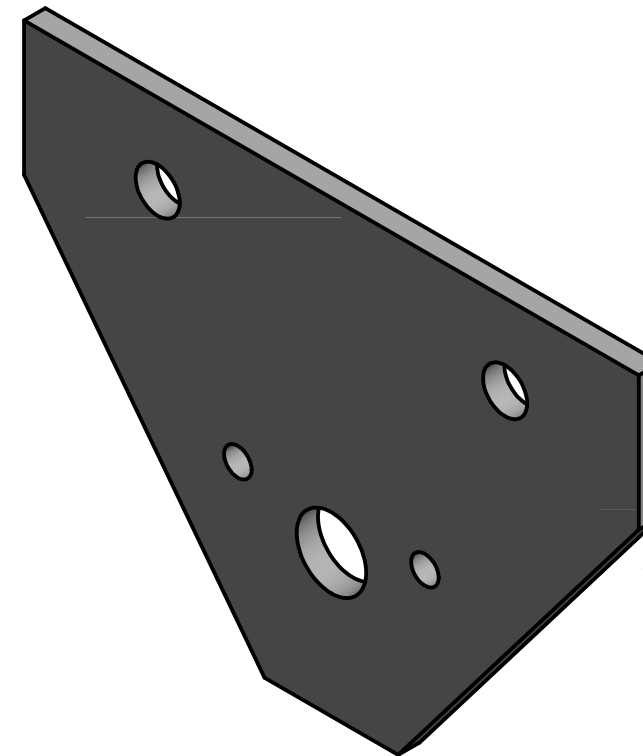

LEGEND:

- Ø DIAMETER
- R RADIUS
- ° DEGREES
- SPOTFACE



DIGITAL DESIGN
GRAPHICS
TECHNOLOGY

WWW.DDGT.NET

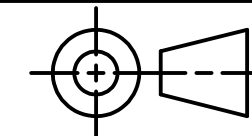

TOLERANCES UNLESS SPECIFIED:
MILLIMETERS
WHOLE NUMBER = ±.5
X = ±.25
XX = ±.12

ANGLE ±1 DEGREE

SURFACES ³² ✓

COURSE: DDGT120

INVENTOR DRAWING NAME
TROLLEY

FIG #: 14-83

DRAFTER: W.VALLADARES

DATE: 12/11/2018

SCALE: AS NOTED

PAGE #: 4 OF 6

PARTS LIST		
ITEM	QTY	PART NUMBER
1.2	4	GUIDE
2	1	HOOK
6	44	ROLLER BEARING

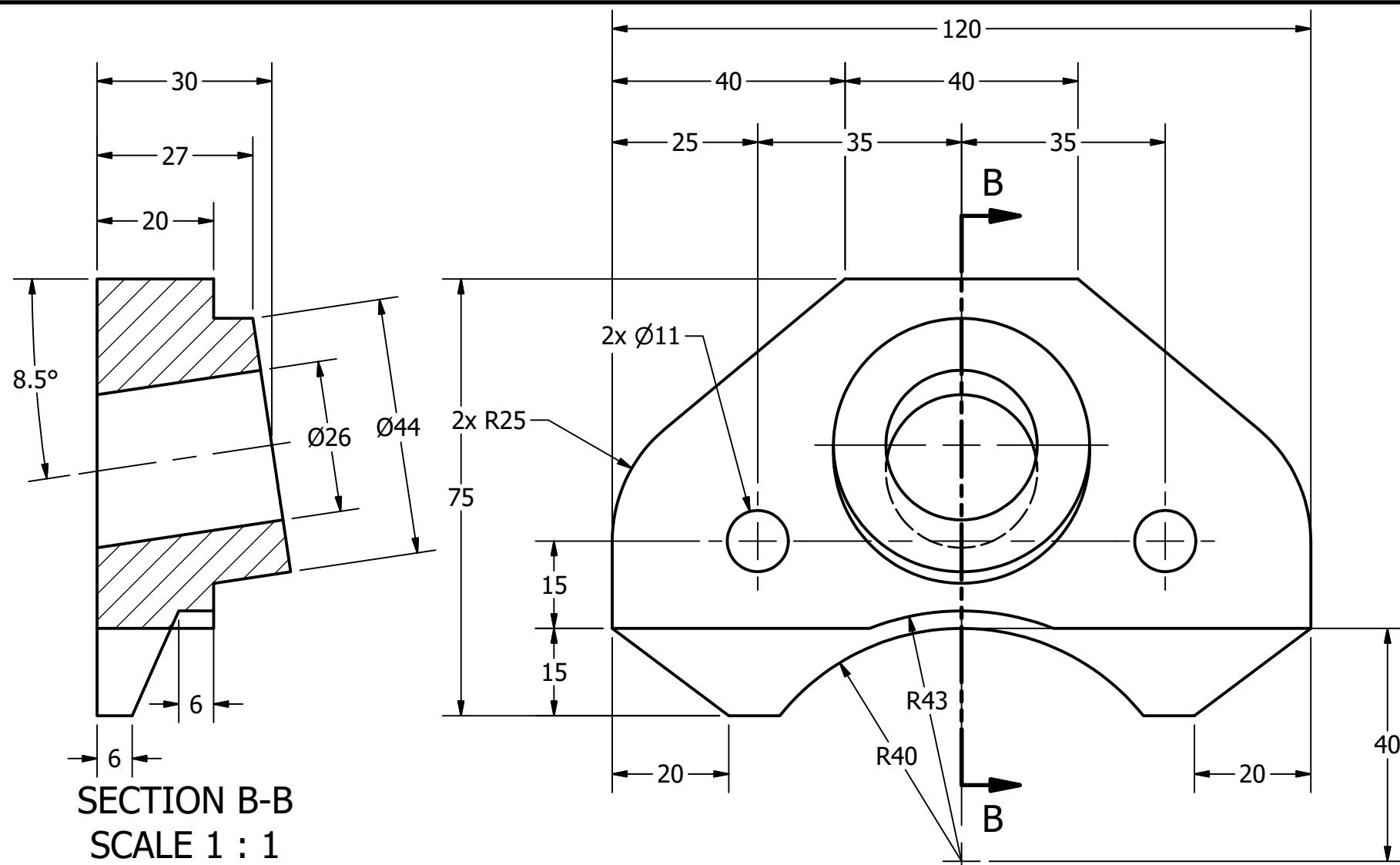

GUIDE
SCALE 1 : 1

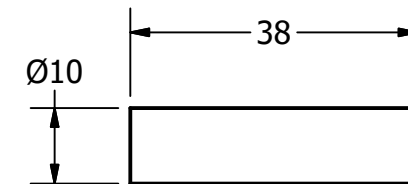
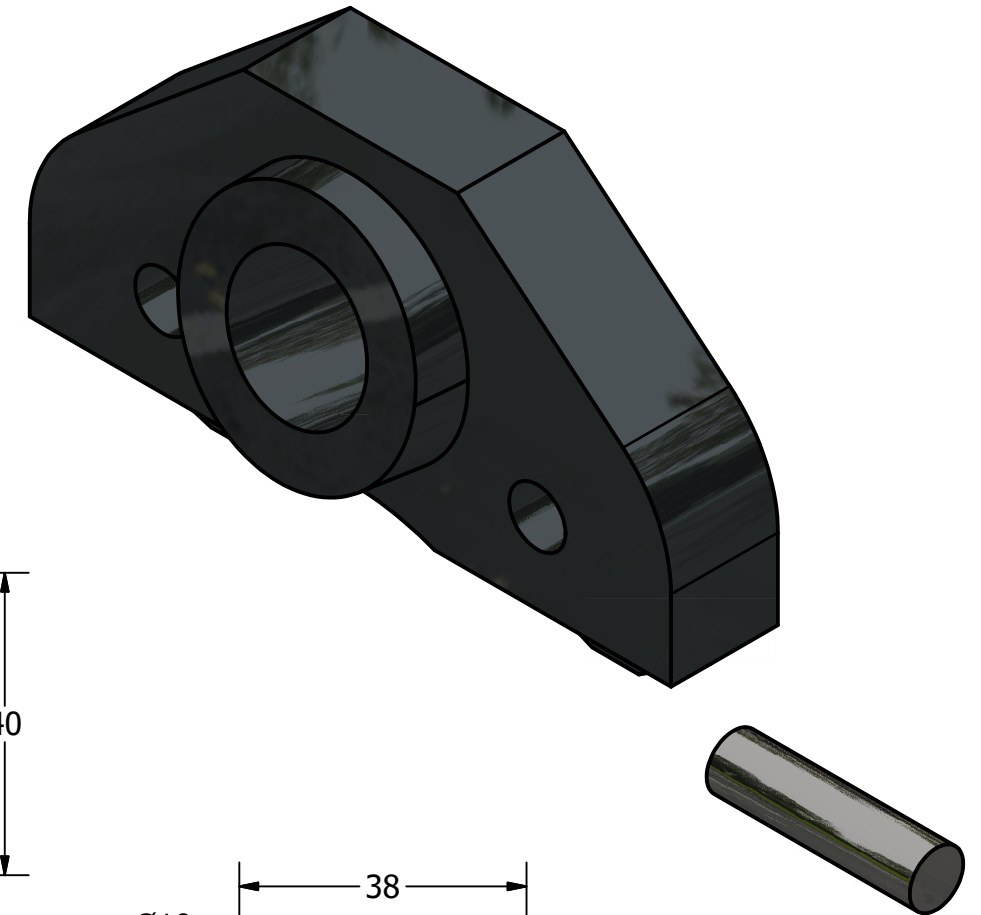

ROLLER BEARING
SCALE 1 : 1

LEGEND:

- Ø DIAMETER
- R RADIUS
- ° DEGREES
- SPOTFACE

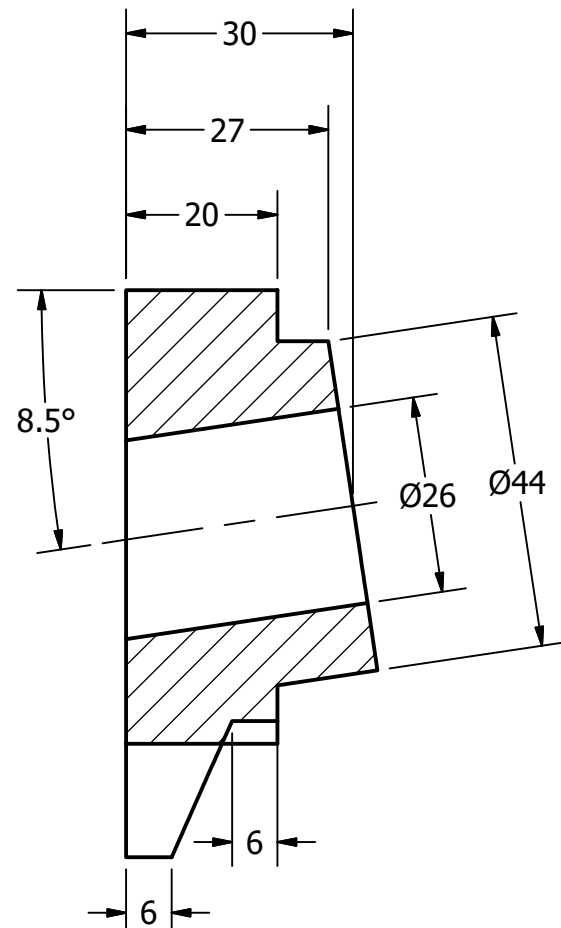

SECTION B-B
SCALE 1 : 1

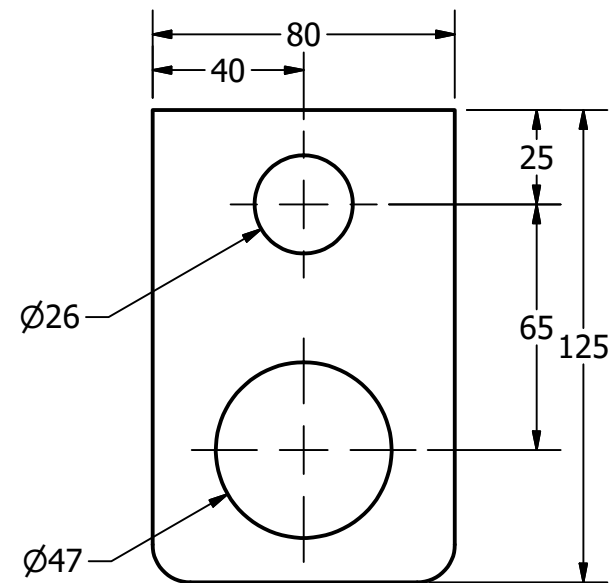

HOOK
SCALE 1 / 2

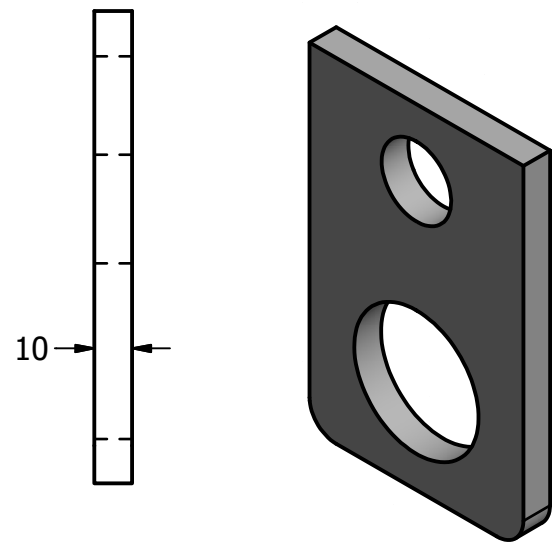

DDGT

DIGITAL DESIGN
GRAPHICS
TECHNOLOGY

WWW.DDGT.NET

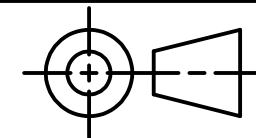

TOLERANCES UNLESS SPECIFIED:
MILLIMETERS
WHOLE NUMBER = ±.5
X = ±.25
XX = ±.12

ANGLE ±1 DEGREE

SURFACES ³² ✓

COURSE: DDGT120

INVENTOR DRAWING NAME
TROLLEY

FIG #: 14-83

DRAFTER: W.VALLADARES

DATE: 12/11/2018

SCALE: AS NOTED

PAGE #: 5 OF 6

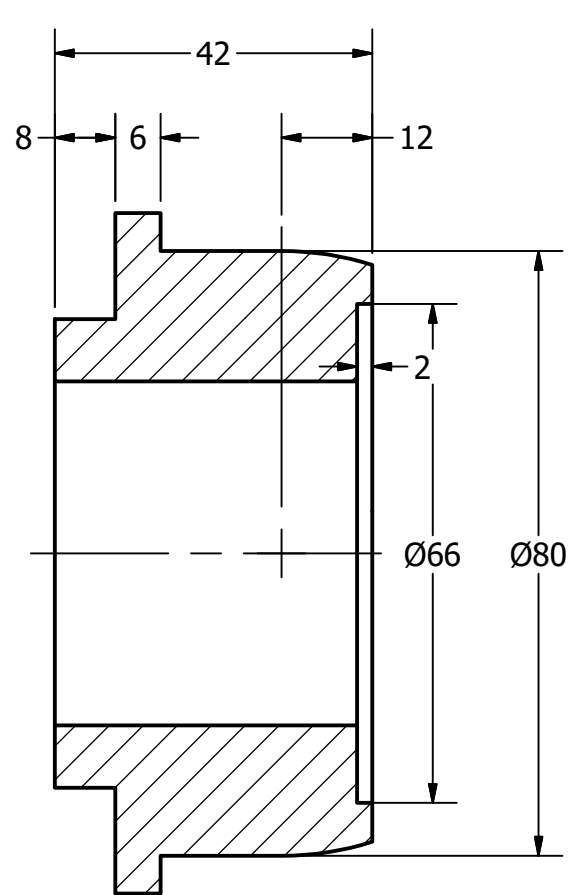

SECTION C-C
SCALE 1 : 1

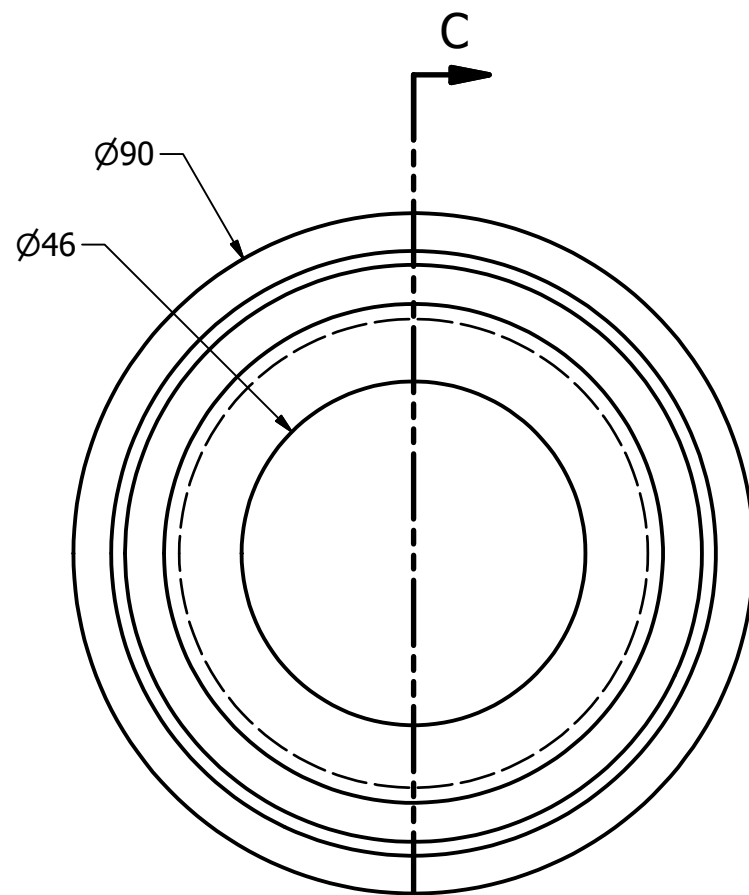

WHEEL
SCALE 1 : 1 C

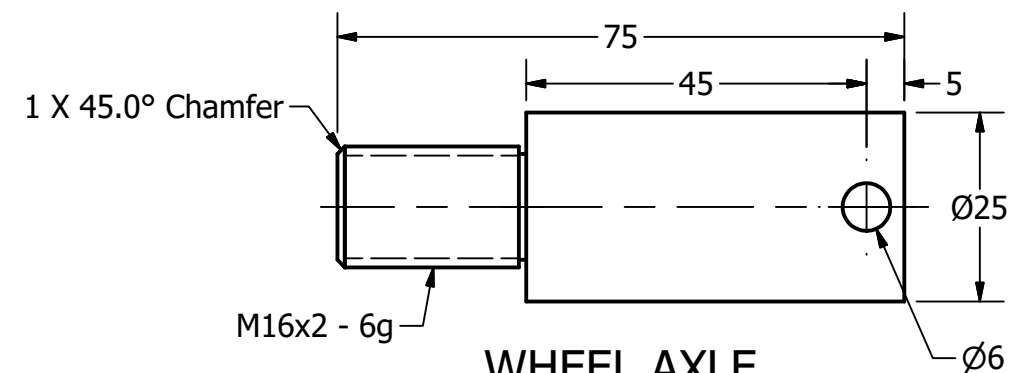
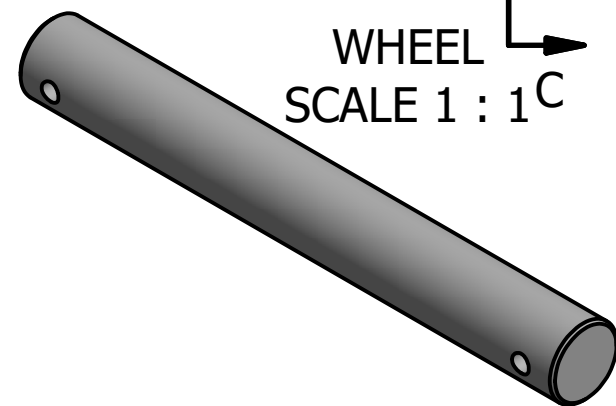

WHEEL AXLE
SCALE 1 : 1

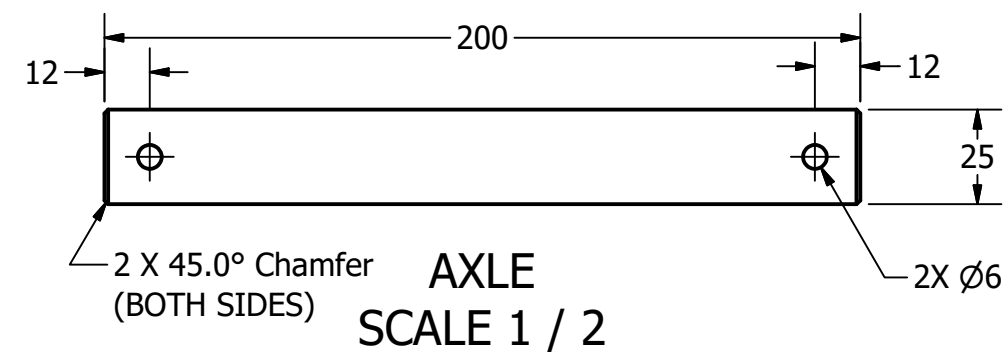
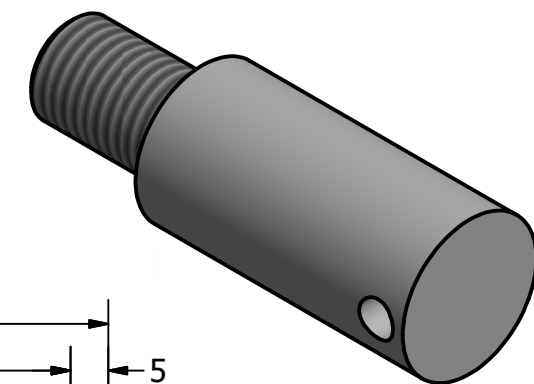

AXLE
SCALE 1 / 2

PARTS LIST		
ITEM	QTY	PART NUMBER
3	4	WHEEL
4	1	AXLE
5	4	WHEEL AXLE

LEGEND:

- Ø DIAMETER
- R RADIUS
- ° DEGREES
- SPOTFACE



DIGITAL DESIGN
GRAPHICS
TECHNOLOGY

WWW.DDGT.NET

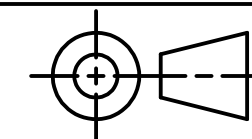

TOLERANCES UNLESS SPECIFIED:
MILLIMETERS
WHOLE NUMBER = ±.5
X = ±.25
XX = ±.12

ANGLE ±1 DEGREE

SURFACES ³² ✓

COURSE: DDGT120

INVENTOR DRAWING NAME
TROLLEY

FIG #: 14-83

DRAFTER: W.VALLADARES

DATE: 12/11/2018

SCALE: AS NOTED

PAGE #: 6 OF 6