

Assembly 3: ENGINE MODEL—Concept for 3-Cylinder Model (*METRIC mm*)

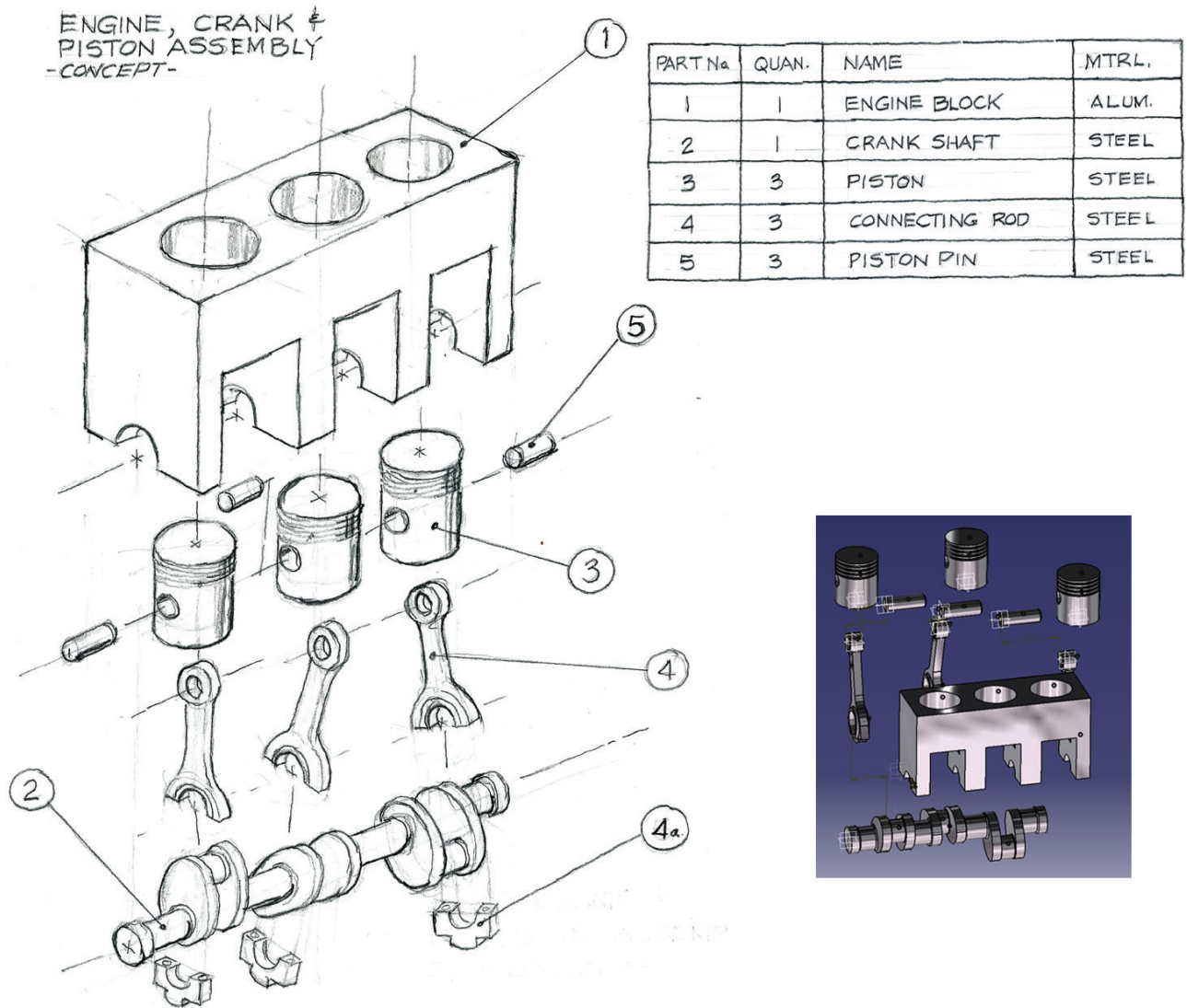

Concept Sketch and Parts for Virtual Engine Assembly

**Figure 20.69**

Engine model—working concept for block, pistons, and crankshaft

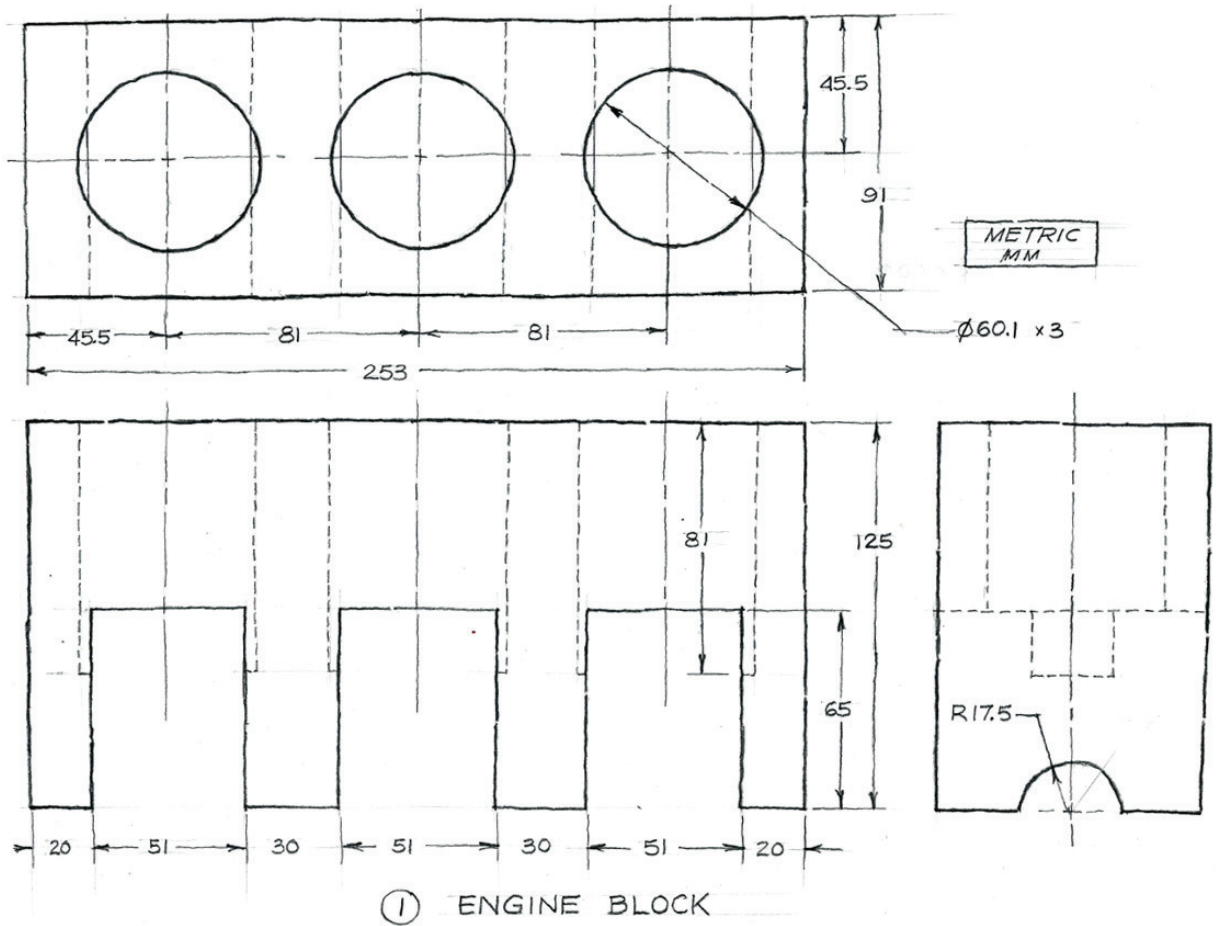
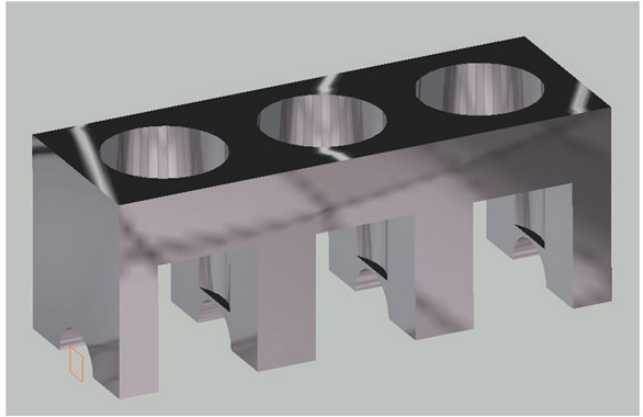

Sketch for Part Number 1: ENGINE BLOCK

**Figure 20.69**

Engine model—working concept for block, pistons, and crankshaft (Continued)

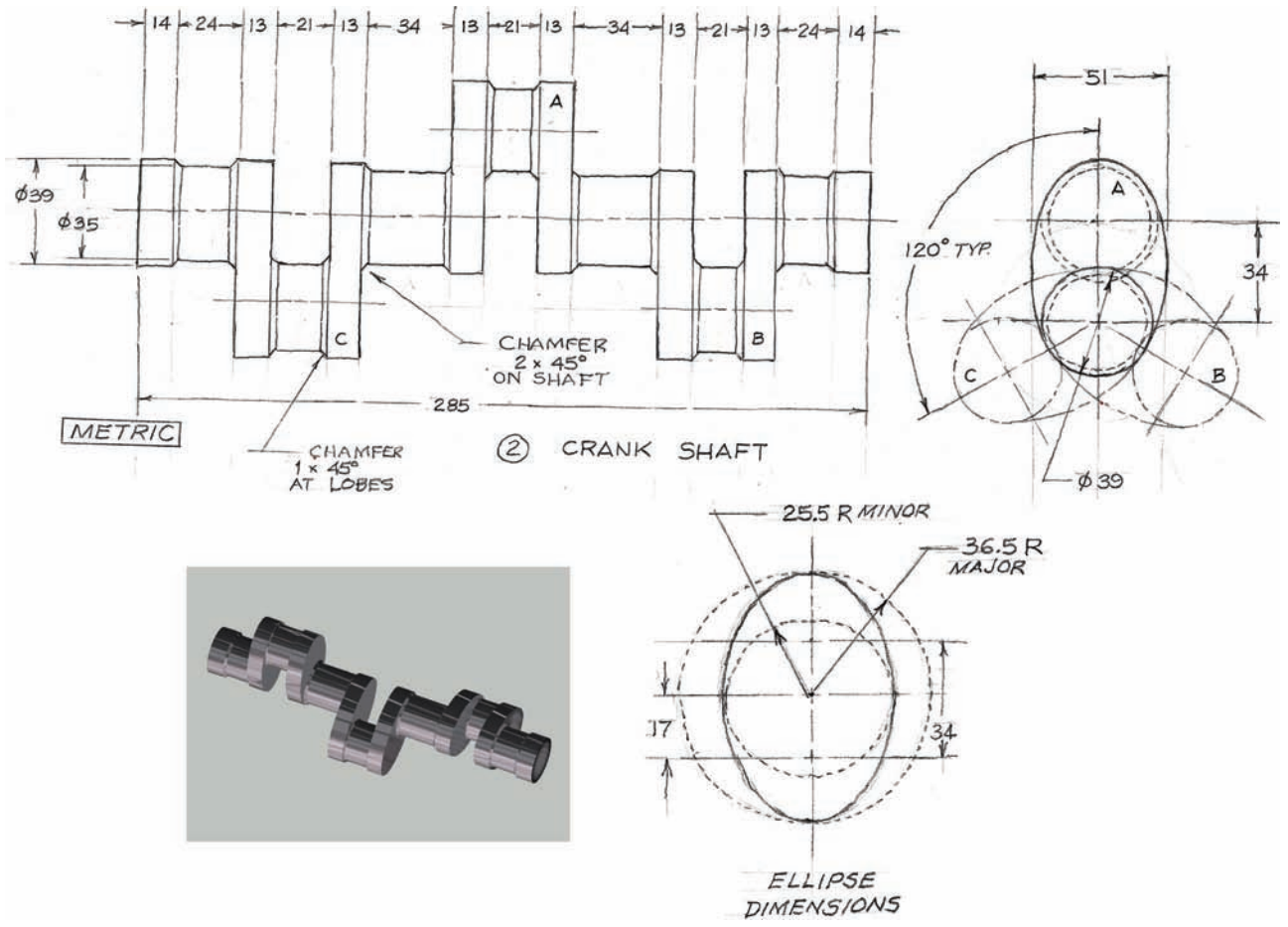

Sketch for Part Number 2: CRANK SHAFT

**Figure 20.69**

Engine model—working concept for block, pistons, and crankshaft (Continued)

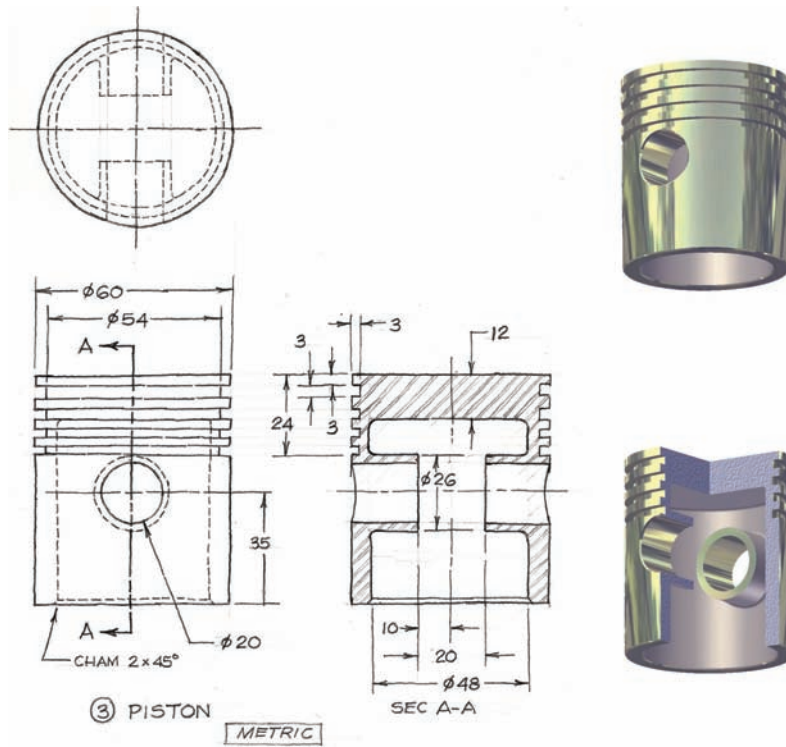

Sketch for Part Number 3: PISTON

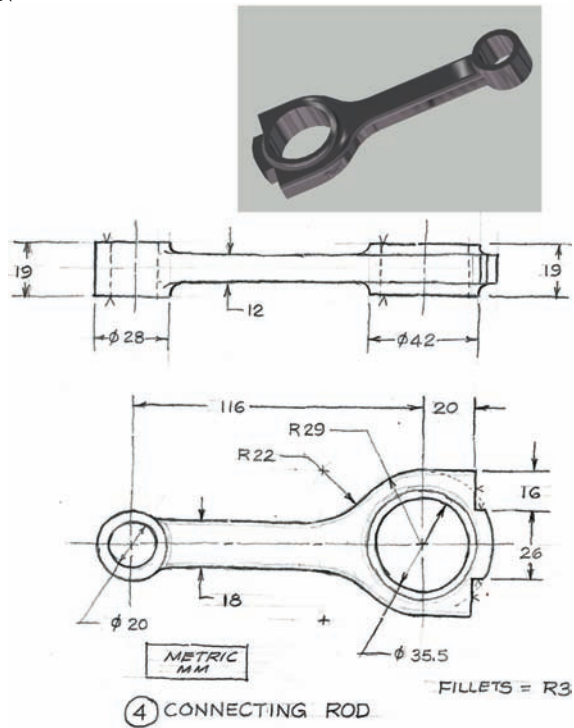

Sketch for Part Number 4: CONNECTING ROD

**Figure 20.69**

Engine model—working concept for block, pistons, and crankshaft (Continued)

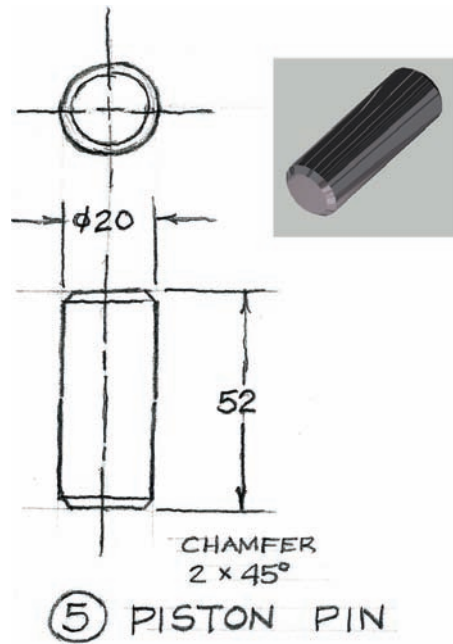

Sketch for Part Number 5: PISTON PIN

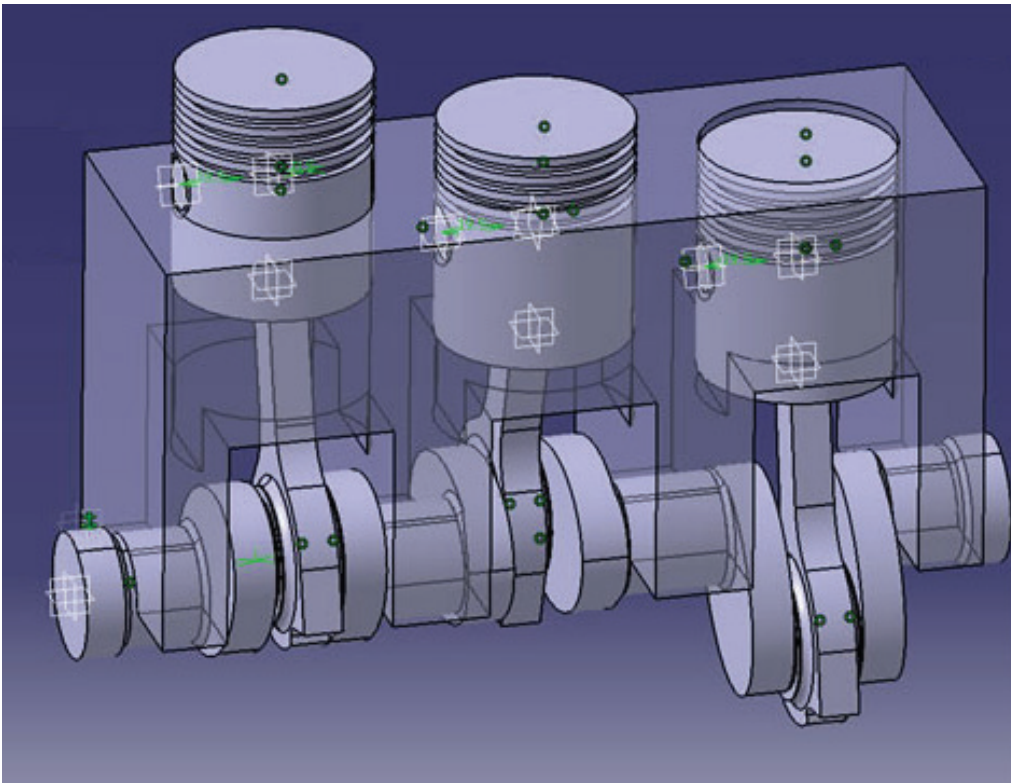

Operational Test Assembly Model: Working Crankshaft and Pistons in Engine Block

**Figure 20.69**

Engine model—working concept for block, pistons, and crankshaft (Continued)