

Make a working drawing of the link shown in Fig. 8-119. The amount of material to be removed from the end surfaces of the hub is .09 in. and .06 in. on the bosses and bottom of the vertical hub. The two large holes are to have an LN3 fit for journal bearings.

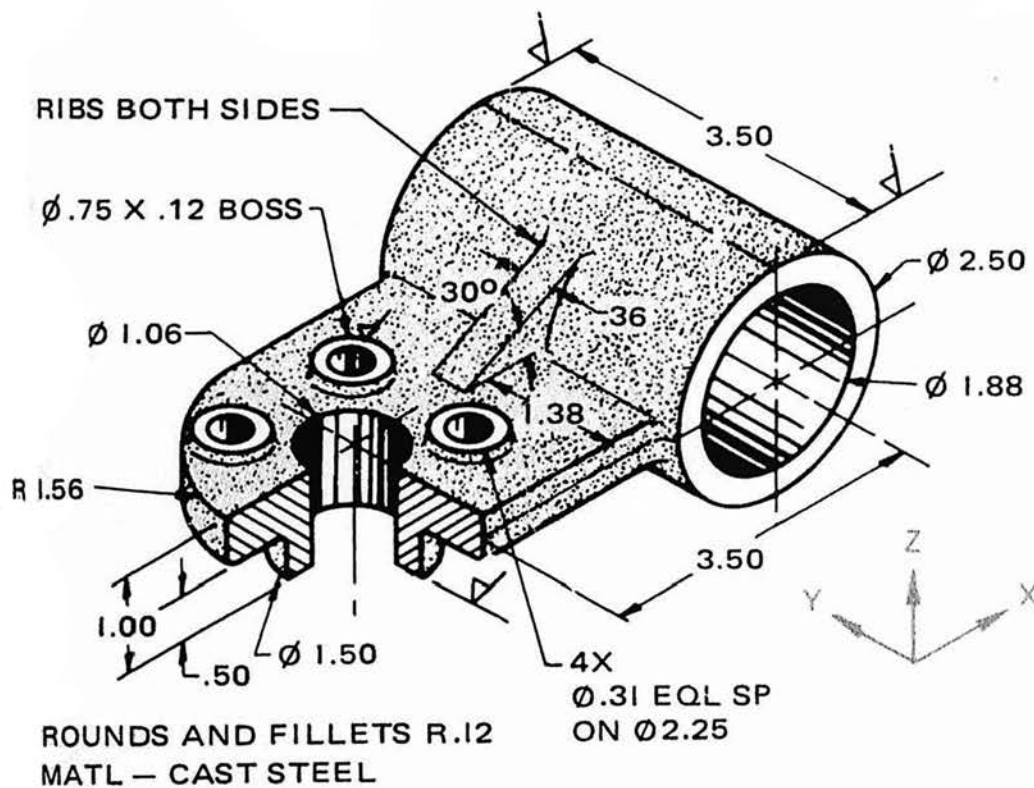

Fig. 8-119 Link.